



 **YORK**

Air-Conditioning Products

YORK Commercial and Industrial HVAC 2025



A more comfortable,
safe and sustainable world

Open Blue

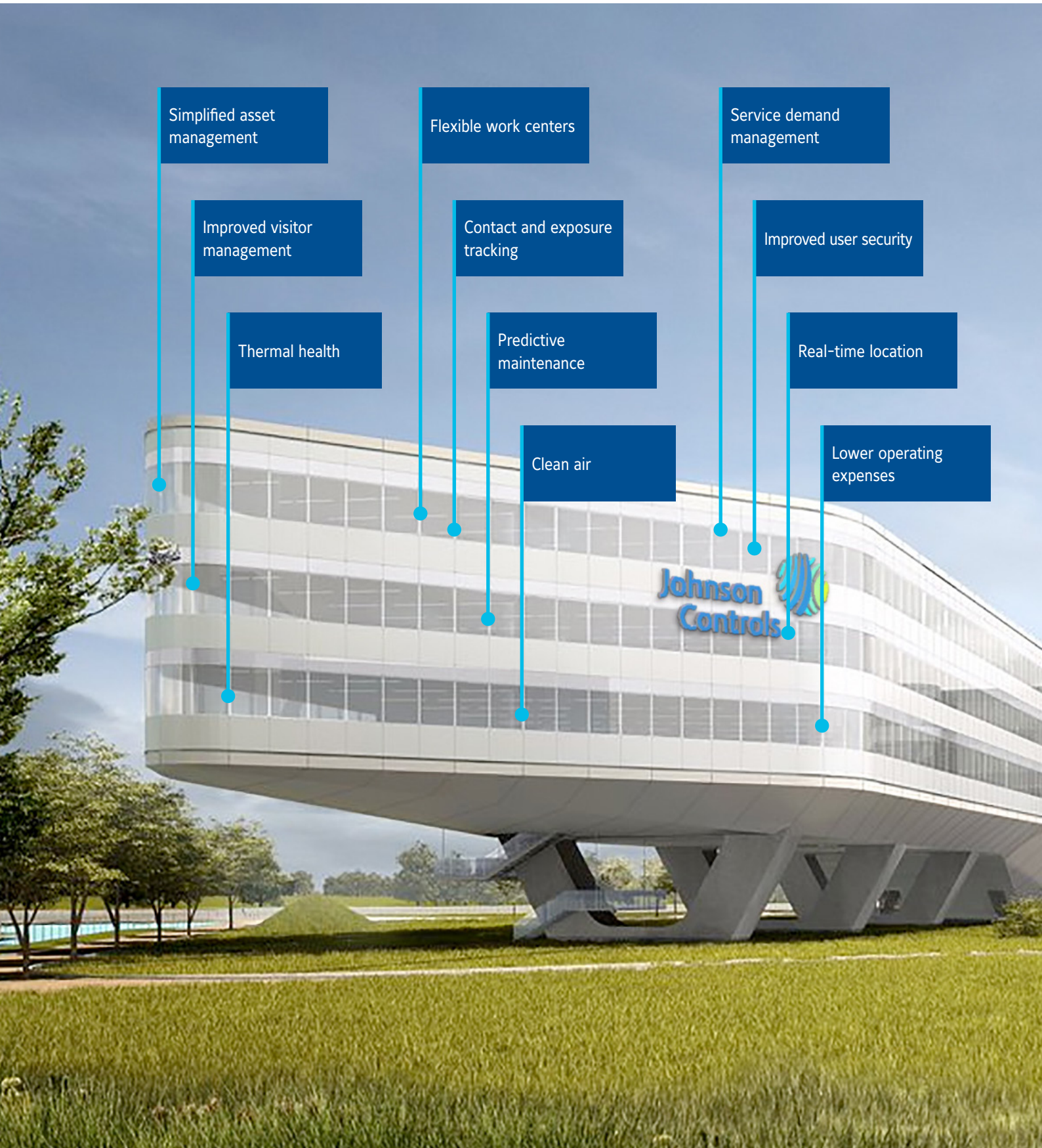

Simplified asset management

Flexible work centers

Service demand management

Improved visitor management

Contact and exposure tracking

Improved user security

Thermal health

Predictive maintenance

Real-time location

Clean air

Lower operating expenses

Johnson Controls

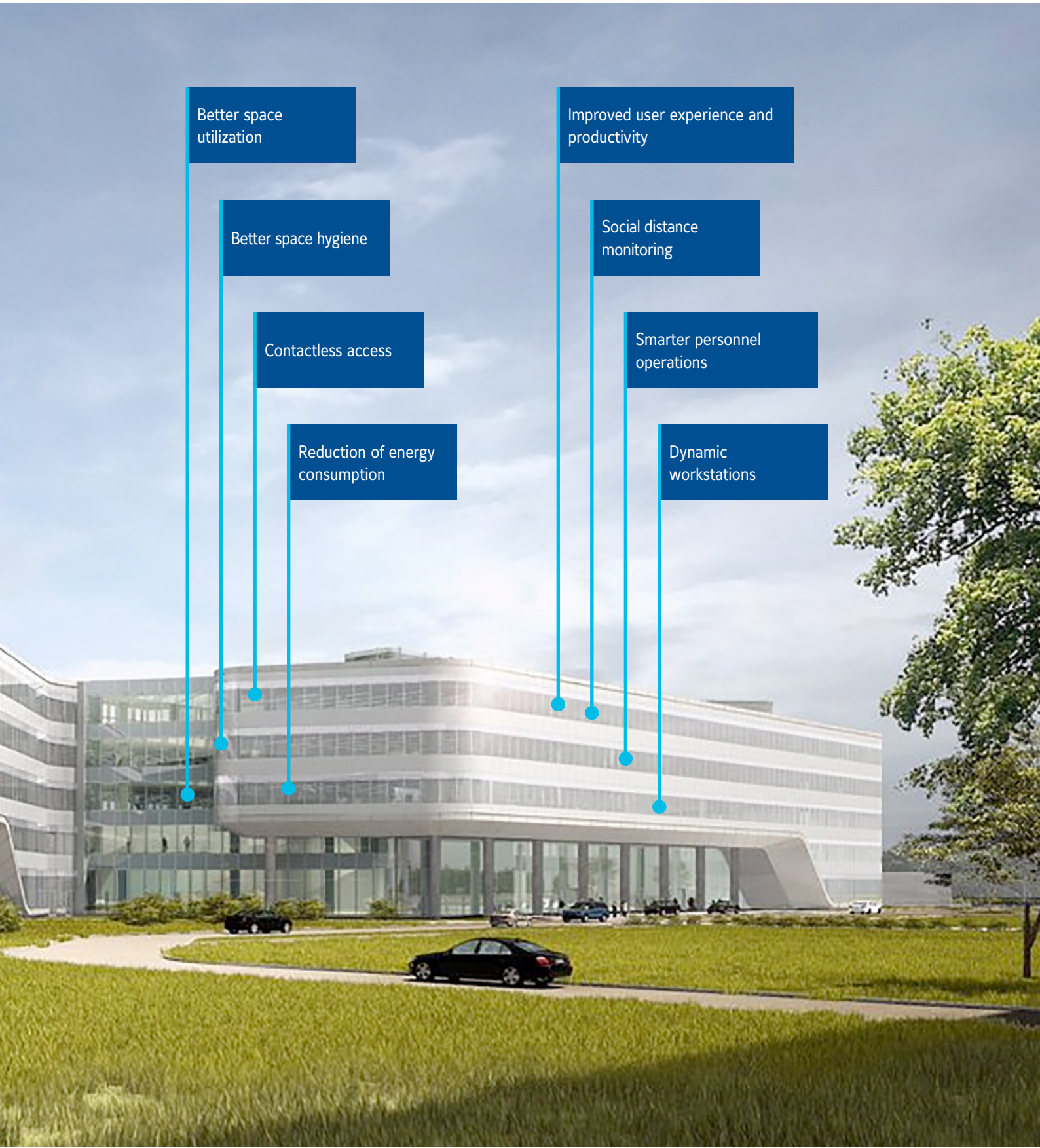

Better space utilization

Improved user experience and productivity

Better space hygiene

Social distance monitoring

Contactless access

Smarter personnel operations

Reduction of energy consumption

Dynamic workstations

Take advantage of a broader range of capabilities

Johnson Controls provides a wide spectrum of innovative products, expert installation and services, and systems integration to help improve operational and energy outcomes and power its customers' mission worldwide.



HVAC equipment

Draw on the most comprehensive HVAC portfolio for commercial and residential buildings of all types, ages and sizes to enhance sustainability, energy use and the indoor environment.

- Chillers: Air-Cooled, Water-Cooled, Heat Pumps and Absorption; Cloud connected chillers
- Condensers and condensing units
- Dedicated outdoor air systems (DOAS)
- Duct-free mini-split systems
- Indoor packaged equipment and Rooftop units
- Variable refrigerant flow (VRF) systems

Security

Help protect and enhance working and living environments today and tomorrow with integrated, customer-specific solutions from the world's leading security company.

- 24/7 remote monitoring
- Access control
- Advanced video surveillance systems and content analytics
- Intrusion detection
- Managed services

Controls

Equip facilities with intelligent HVAC controls to keep occupants comfortable, run equipment efficiently and optimize operating budgets.

- Actuators
- Control panels
- Control sensors
- Current sensors and transducers
- Thermostats
- Valves
- Variable speed drives

Fire, life-safety and hazard protection

Help keep people and assets safe with comprehensive solutions, design, installation, service and monitoring from a world leading fire and life-safety systems provider.

- Fire alarm systems
- Fire sprinkler systems
- Fire suppression systems (stationary and mobile)
- Mass notification systems
- Special hazard solutions

Optimization and retrofit services

Make the most of existing building and financial assets through cost-effective upgrades, central plant strategies, and financing solutions.

- Central chiller plant optimization
- Clean energy assessments
- Energy performance contracts
- Energy retrofits
- Equipment financing
- Healthcare environment optimization
- Public/private partnerships
- Technology refresh services
- Turnkey upgrades and retrofits
- Chiller Rental Solutions

Lighting controls and retrofit

Save energy, minimize costs and meet organizational goals with a range of services, from business remodels, to new construction lighting design, to municipal street lights.

- Lighting retrofits
- Street and roadway lighting
- Turnkey lighting upgrades

Energy storage

Rely on our innovative distributed energy storage products to better manage energy use, cut costs and ensure electrical back-up for a building, campus or enterprise.

- In-building distributed energy storage system
- Modular distributed energy storage system

Retail solutions

Gain real-time insights into retail facilities, inventories, employees & customers to achieve maximum business performance in a digitally driven shopping world.

- Loss Prevention
- Inventory Intelligence
- Traffic Insights

Operational intelligence and loss prevention

Helps minimize costs, maximize operational performance and enhance return on investment in security programs with business intelligence solutions.

- Information management solutions
- Real-time location systems (RTLS) for asset management
- Video and traffic analytics

Building services and parts

Tap into resources of the industry's largest service network for HVAC, security and life-safety system installation and product support. More than 12,000 technicians working out of nearly 500 local offices can provide 24x7x365 proactive monitoring, remote and on-site service and repair, and replacement parts.

- Aftermarket parts
- Building remote monitoring
- Building system and HVAC repair
- Planned and preventive maintenance
- Predictive and diagnostic services
- Security and life-safety system repair

Building automation systems

Connect commercial HVAC, lighting, security and protection systems on one platform. Vital data and insights improve efficiency, productivity, and occupants' comfort and safety.

- Metasys building automation system
- Metasys Enterprise Optimization applications
- Metasys Room Automation Solution
- Hotels Guest Room Management Solution

Air systems

Use efficient air flow building-wide to create healthy, comfortable and visually appealing environments that increase work productivity and occupant satisfaction.

- Air handling units
- Air measuring
- Chilled beams
- Dampers
- EcoAdvance™ HVAC load reduction (HLR) module
- Energy recovery ventilators
- Fan and blower
- Fans
- Filtration
- Grilles and diffusers
- Heating coils and cooling coils
- Louvers
- Under floor air distribution
- Unit ventilators
- Variable air volume (VAV) terminals
- Variable speed drives

Building wide systems integration

Construct a smarter building by converging building, business/IT and specialty systems on an intelligent infrastructure. Let us streamline the process to measurably improve initial and lifecycle costs, enhance function, ensure connectivity and create an innovative, optimized, sustainable environment.

Reference sites

Our commitment to sustainability and energy efficiency dates back to 1885, with Warren Johnson's invention of the first electric room thermostat. Since then our focus has always been to increase a building's efficiency and operational performance.

The following sites represent building solutions we have developed for our customers based on wide-ranging cross industrial experience in HVAC&R equipment, controls, fire and security systems, and services for commercial and industrial buildings.

Oceanogràfic Valencia

Absorption chiller solution to save energy costs and improves performance.



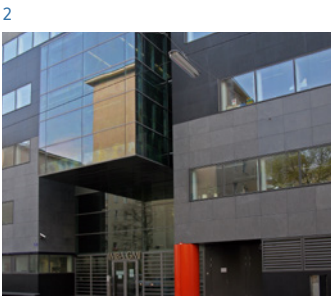
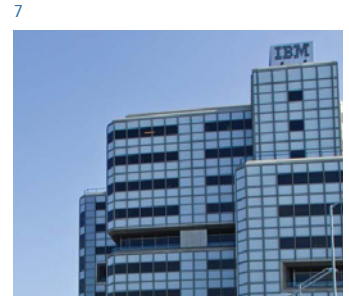
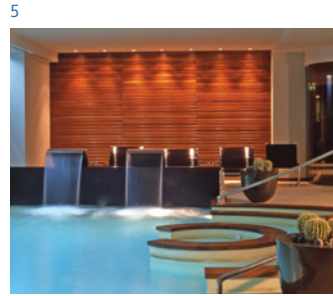
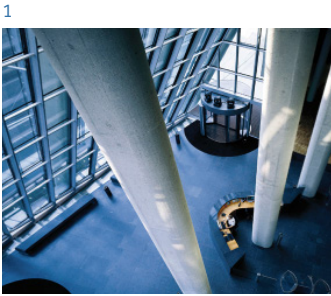

1
First building in Austria to be awarded a Green Building Certificate
 Johnson Controls Metasys Building Automation System helps UNIQA Towers in Vienna achieve a Green Building Certificate for energy efficiency.

3
Cisco. UK
 Smart+Connected Communities installation designed to save energy costs and improves performance.

5
THI GROUP
 Solutions for the hospitality industry.

7
IBM Headquarters
 Adding value and conserving energy from the inside out.

2
The Gregor Mendel Institute
 State-of-the-art technologies for world-class research.

4
Fiserv (Europe) Ltd
 Utilising latest developments in chiller's technology delivers energy savings and ongoing cost reductions for Fiserv.

6
British Embassy. Berlin
 Full Lifecycle Solution for British Government's first Private Finance Initiative outside the UK.

8
Cologne Convention Center
 The centrifugal chillers and the building automation system are indispensable in creating and managing an optimal indoor environment.

A complete range of HVAC-R solutions for your facilities

METASYS BUILDING MANAGEMENT SYSTEM

METASYS SERVER
Support of IT standards and technologies, Multi-platform web-based user interface, long-term storage

OPEN APPLICATION SERVER (OAS)
Metasys system that combines supervisory server and engine capabilities in a single software offering, with optional, add-on features

SUPERVISORY NETWORK ENGINE
Family of IP connected Supervisory Network Engines for all sizes of building management systems

SUPERVISORY NETWORK CONTROLLER
Family of IP connected Supervisory Network Controllers with onboard Input/Output (IO) points and optional integral display

GENERAL PURPOSE CONTROLLER
BACnet IP and MS/TIP general purpose field controllers with optional integral or remote display

INPUT/OUTPUT MODULES
Scalable family of configurable Input/Output (IO) modules

VAV CONTROLLERS
Complete family of BACnet IP and MS/TIP VAV controllers with optional damper position feedback. Support standard applications of fully programmable

FIELD USER INTERFACES
Self configuring local touch screen display or web server user interface options allowing simplified access to equipment or controls

ROUTERS, GATEWAYS, ADAPTERS & REPEATER
A range of gateways and adapters for enhanced integrations on Metasys SNE and SNC. Supporting communication standards such as Mbus, LON and others. Range also includes a repeater for RS485 networks

INTEGRATION SOLUTIONS
Interfaces Metasys with legacy systems, fire and security systems and systems with proprietary and standard protocols

EASY IO BUILDING MANAGEMENT SYSTEM

FS SERIES
Server-Class BloT Programmable Controllers

FW SERIES
Wireless & Wired IP-Class BloT Programmable Controllers

FC SERIES
BACnet MSTP Programmable Controller

FD-201 SERIES
I/O expansion modules

FT SERIES
2 Points, Wi-Fi Controller

FW-VAV
The FW-VAV is a network VAV-Controller with an integrated 4 Nm actuator, pressure differential sensor and a suite of VAV-applications, kits and multifunctional adapter widgets

CRITICAL ENVIRONMENTS SOLUTION

CRITICAL ENVIRONMENT CONTROLLER & MONITOR
Complete line of controllers and monitors for room pressure and fume hoods

CENTRAL-MONITORING STATION
The CMS-2000 Central Monitoring Station provides instant status verification for up to eight rooms, eight fume hoods, or a combination of rooms and hoods

METASYS CRITICAL ENVIRONMENTS CONTROLLER AND DISPLAY
Full Metasys solution, programmable with CCT. Includes applications (.caf) for Pressure and Volumetric Offset with Pressure Override

VENTURI VALVE SERIES
Constant Volume Venturi air valves & fast-acting actuators with Universal Valve Modules (UVM)

HVAC CONTROL PRODUCTS

TERMINAL UNIT VALVES AND ACTUATORS **NEW**
Complete offering of valves and actuators for terminal unit applications

CONTROL VALVES AND ACTUATORS **NEW**
Ball, globe and butterfly valves with electric actuators and PICV applications

DAMPER ACTUATORS
Spring and non-spring return rotary actuators for air, fire and smoke dampers

PLANT SENSORS
Plant Temperature, Humidity, CO₂, VOC, Dew point and Delta pressure, with Passive, Analog, Modbus & BACnet communication

ROOM SENSORS
Room Temperature, Humidity, CO₂, VOC, with Passive, Analog, Modbus & BACnet communication

ALL IN ONE NETWORK SENSOR **NEW**
Temperature, Humidity CO₂, presence and color display

THERMOSTATS
Line powered Fan Coils thermostats stand alone, Modbus, BACnet and KNX communicating

SMART EQUIPMENT THERMOSTAT
24VAC color screen thermostat with proportional/ On-Off /multistage controls with seamless Metasys integration over BACnet MSTP

CONFIGURABLE CONTROLLER

SMART EQUIPMENT CONTROLLERS
Family of controllers and accessories specifically designed for HVAC/R equipment optimization

TERMINAL UNIT CONTROLLER PLUS
Designed for local complete control of unitary equipment with BACnet supervisory communication

PENN REFRIGERATION PRODUCTS

PRESSURE SWITCHES & THERMOSTATS
The pressure switches, thermostats and humidistats are designed for refrigeration, cooling, heating, ventilation and air-conditioning applications

ELECTRONIC CONTROLS & TRANSDUCERS
The controllers provide a high quality long lasting solution for control of any commercial refrigeration unit

WATER VALVES & FLOW CONTROLS
Control water flow rate to a condenser by directly sensing pressure changes in a refrigerant circuit. Used with sea water, swimming pool water, ethylene glycol or other liquids

ROOM AUTOMATION SOLUTION

ROOM AUTOMATION SOLUTION
Complete range of KNX devices for lighting, sunblinds, access and HVAC control

YORK FAN COIL UNITS

YFCN / YFCN-ECM
Cooling capacity: 0.7 – 7.4 kW
Exposed and concealed, horizontal or vertical mounting, EC variable speed motor option

YFTS-ECM
Cooling capacity: 0.4 – 3.8 kW
Exposed and concealed, vertical mounting, tangential fan, EC variable speed motor

LASER & LOW BODY / LASER & LOW BODY - ECM
Cooling capacity: 0.6 – 9.7 kW
Exposed and concealed, horizontal or vertical mounting, EC variable speed motor option

YHVP / YHVP-ECM
Cooling capacity: 1.17 – 3.81 kW
Residential wall mounted, infrared remote option, EC variable speed motor option

High static pressure blower YHPL / YHPL-ECM
RFHP-O / RFHP-O-ECM
Cooling capacity: 1.4 – 30.6 kW up to 250 Pa ESP maximum, ducted unit horizontal mounting without case, EC variable speed motor option

YGFC **NEW**
Cooling capacity: 1.5 – 8.5 kW up to 60Pa ESP maximum, ducted horizontal

YDFC **NEW**
Cooling capacity: 6.2 – 16.2 kW up to 100Pa ESP maximum, ducted horizontal

YEFB / YEFB-ECM
Cooling capacity: 4.2 – 27.5 kW up to 250Pa ESP
Horizontal mounting without case, EC variable speed motor option

YKEY / YKEY-ECM
Cooling capacity: 1.1 – 10.2 kW
Ceiling mounted, coanda effect, 2 and 4 pipe versions available, EC variable speed motor option

YHK / YHK-ECM
Cooling capacity: 1.3 – 15.1 kW
Ceiling mounted cassette, 2 and 4 pipe versions available, EC variable speed motor option

YORK CLOSE CONTROL AC UNITS

YC-P / YC-G / YC-R SERIES
Cooling capacity: 8.0 – 170.2 kW
Brushless DC compressors with inverter technology and brushless EC motor fans. Upflow, downflow and horizontal supply options, R410A

YC-H SERIES
Cooling capacity: 32.3 – 141 kW
Brushless DC compressors with inverter technology and brushless EC motor fans, R410A

YC-W SERIES FAN WALL UNITS
Cooling capacity: 100 – 350 kW
Horizontal air flow, High-efficiency ECM fans

YORK ROOFTOP EQUIPMENT

ACTIVA ROOFTOP
Cooling capacity: 18 – 39 kW
Cooling only, Heat pump, Cooling only + Gas heat, Heat pump + Gas heat, R410A

ACTIVA AGR ROOFTOP
Cooling capacity: 20 – 45 kW
Cooling only, Heat pump, Scroll compr. R410A

ACTIVA ASR ROOFTOP
Cooling capacity R410A: 50 – 219 kW
Cooling capacity R32: 95 – 140 kW
Cooling only, Heat pump, scroll compressors, R410A, R32

LARGE ACTIVA ROOFTOP
Cooling capacity: 108 – 169 kW
Cooling only, Heat pump, Scroll compressors, R410A

YORK AIR HANDLING UNITS & INDOOR AIR QUALITY OPTIONS

YMA **NEW**
Customized
Airflow range: 1,000-200,000 m³/h

YMB
Semi-Customized
Airflow range: 700-100,000 m³/h

YMD **NEW**
Standard
Airflow range: 1,000-112,000 m³/h

YMB-SP
Swimming Pools
Airflow range: 1,000-45,000 m³/h

YMF-S/R/H/F
Packaged Heat Pump
Airflow range: 1,500-24,500 m³/h

YBV-NG...s **NEW**
Compact - Suspended AHU
Counter-flow Plate Heat Exchanger
Airflow range: 150-3,300 m³/h

YBV-NGA...c **NEW**
Compact - Floor Mounted AHU
Rotary or counter-flow Plate Heat Exchanger
Airflow range: 690-8,000 m³/h

YBV-NG...c **NEW**
Compact - Top AHU
Counter-flow Plate Heat Exchanger
Airflow range: 1,250-4,000 m³/h

YKR
Compact
Rotary Heat Exchanger
Airflow range: 600-10,600 m³/h

YKC
Compact
Counter-flow Plate Heat Exchanger
Airflow range: 1,500-7,360 m³/h

YKL
Compact - Low profile
Counter-flow Plate Heat Exchanger
Airflow range: 250-2,550 m³/h

YKH
Heat Recovery Ventilation Unit
Counter-flow Plate Heat Exchanger
Airflow range: 65-620 m³/h

YKH-2G **NEW**
Heat Recovery Ventilation Unit
Counter-flow Plate Heat Exchanger
Airflow range: 150-600 m³/h
Energy class A/A+

YORK ABSORPTION CHILLERS R718 (Natural-Water)

SINGLE EFFECT HOT WATER OR STEAM DRIVEN
WFC SC / YHAU-CL/CH / YHAU-C
Cooling capacity: 18 – 7,033 kW

SINGLE EFFECT DOUBLE LIFT HOT WATER DRIVEN
YHAU-CL-DXS
Hot Water Leaving down to 40°C
Cooling capacity: 176 – 2,500 kW

DOUBLE EFFECT STEAM OR HOT WATER DRIVEN
YHAU-CW / YHAU-CHW
Cooling capacity: 422 – 14,065 kW

DOUBLE EFFECT DIRECT FIRED
YHAU-CXR / YHAU-CG
Cooling capacity: 105 – 5,600 kW

DOUBLE EFFECT EXHAUST GAS DRIVEN
YHAU-CE
Cooling capacity: 527 – 3,516 kW

MULTI ENERGY
Hot water & Steam & Exhaust gas
YHAU-CE-J / YHAU-CW-J
Cooling capacity: 527 – 5,064 kW

SINGLE OR DOUBLE EFFECT LOW LEAVING (0° or -5°C)
Hot water & Steam driven
YHAU-L / YHAU-LL
Cooling capacity: 176 – 2,500kW



Eurovent certified



Heat Recovery Option



Low GWP

YORK CHILLERS

AIR-COOLED

	AMICHI YMAE Cooling capacity: 38 – 124 kW DC Inverter technology, EVI Scroll compressor, R454B	 
	AMICHI YMPA Cooling capacity: 41 – 254 kW DC Inverter technology, Scroll compressor, hydro kit, R454B and R410A	
	TEMPO YLAA Cooling capacity: 198 – 640 kW Scroll compressors, hydro kit, R454B	 
	YGT Cooling capacity: 401 – 983 kW Variable-speed screw compressor with HFO, Heat recovery, Hydro kit, R1234ze	
	YVAA-B New Generation Cooling capacity: 648 – 2,000 kW Variable-speed screw compressor, R1234ze and R513A	 
	YVFA Cooling capacity: 577 – 1,664 kW Air-Cooled VSD Screw Free Cooling, R513A	
	YVAM Cooling capacity: 1,400 – 1,800 kW Air-Cooled Magnetic Bearing Centrifugal, R1234ze	 
	YAS Cooling capacity: 32 – 353 kW Reciprocating compressor, R290 (Propane)	
WATER-COOLED		
	YMWV/YMRA Cooling capacity: 21 – 193 kW Scroll compressor, R410A	
	YCSE/YCRE Cooling capacity: 140 – 240 kW Screw compressor, R513A and R134a	
	YRW Cooling capacity: 151 – 321 kW Screw compressor, R513A	
	YWW Screw Cooling capacity: 85 – 190 kW Inverter Screw compressor, R1234ze	
	YWW Scroll Cooling capacity: 56 – 383 kW Scroll compressor, R454B and R410A	
	YVWH Cooling cap.: 313 – 1,189 kW Variable-speed screw compressor, R1234ze, R515B and R513A	 
	YZ Cooling capacity: 580 – 5,500 kW Variable Speed Centrifugal, Magnetic Bearings, R1233zd(E)	
	YMC² Cooling capacity: 800 – 2,800 kW Variable Speed Centrifugal, Magnetic Bearings, R1234ze, R515B and R513A	 
	YK Cooling capacity: 800 – 11,250 kW Centrifugal compressor, R1234ze, R515B and R513A	

SERVICE OFFERINGS



CHILLER DIAGNOSTIC TOOL
Proactive parts replacements recommendations to maintain efficiency, boost uptime and provide savings on unplanned repair costs.



YORK CHILLER ACCESS MANAGER
Provides owners with control and visibility over who is operating, maintaining and servicing their chiller, ensuring the protection of an asset critical to facility operation.





OPENBLUE CONNECTED CHILLERS
Cloud-hosted analytical tool that cut costs, maximize uptime, and provide targeted maintenance to keep your chiller running compliant, efficient and reliable.

YORK HEAT PUMPS

AIR-COOLED (2 pipes)

	AMICHI YMAE Reversible, water up to 60°C Heating capacity: 42 – 139 kW DC Inverter technology, EVI Scroll compressor, R454B	 
	AMICHI YMPA Reversible, water up to 55°C Heating capacity: 45 – 256 kW DC Inverter technology, Scroll compressor, hydro kit, R454B and R410A	
	YLPB Reversible, water up to 55°C Heating capacity: 344 – 653 kW Scroll compressors, hydro kit, R410A	
	YCPB Reversible, water up to 60°C Heating capacity: 305 – 507 kW EVI Scroll compressors, R454B	 
	YTH Reversible, water up to 65°C Heating capacity: 18 – 68 kW Scroll compressors, R454C	
	YTL Reversible, water up to 55°C Heating capacity: 202 – 1,151 kW Scroll and screw compressors, R454B and R513A	 
	YAS/RC-WP Reversible, water up to 55°C Heating capacity: 103 – 334 kW Reciprocating compressors, R290 (Propane)	
AIR-COOLED (4 pipes)		
	YHA Reversible, water up to 60°C Heating capacity: 22 – 464 kW Scroll compressor, R410A	
	YLZ Reversible, water up to 65°C Heating capacity: 24 – 210 kW E.V.I. scroll compressor, ductable option, R410A	
	YCH Reversible, water up to 55°C Heating capacity: 50 – 1,455 kW Scroll and screw compressors, R454B, R410A, R513A, R134a	
WATER-COOLED		
	YMWV-HP Reversible, water up to 55°C Heating capacity: 24 – 215 kW Scroll compressor, R410A	
	YCSE HP Water up to 50°C Heating capacity: 170 – 300 kW Screw compressor, R513A and R134	
	YWH Water up to 78°C Heating capacity: 38 – 301 kW Scroll compressor, R134a	
	YWW Screw Water up to 65°C Heating capacity: 100 – 225 kW Inverter Screw compressor, R1234ze	
	YWW Scroll Water up to 50°C Heating capacity: 73 – 484 kW Scroll compressor, R454B and R410A	 
	YVWH Water up to 50°C Heating cap.: 315 – 1,250 kW Variable-speed screw compressor, R1234ze, R515B and R513A	 
	YVWH HP Water up to 80°C Heating cap.: 900 – 1,800 kW Variable-speed screw compressor, R1234ze and R515B	  
	YZ Water up to 45°C Heating capacity: 1,000 – 6,800 kW Variable Speed Centrifugal, Magnetic Bearings, R1233zd(E)	
	YMC² Water up to 65°C Heating capacity: 1,600 – 2,800 kW Variable Speed Centrifugal, Magnetic Bearings, R1234ze, R515B and R513A	 
	YK Water up to 50°C (Std) / 70°C (HP) Heating capacity: 1,000 – 9,000 kW Centrifugal compressor, R1234ze, R515B and R513A	 
	CYK Water up to 93°C Heating capacity: 1,500 – 10,000 kW Dual centrifugal compressors in series, R1234ze	  
ABSORPTION HEAT PUMPS		
TYPE I – R718 (Natural Water)		
YHAP-CL/CH / YHAP-C / YHAP-CW Hot Water Leaving up to 95°C Heating capacity: 900 – 40,000 kW Hot Water, Steam, Natural Gas or Exhaust Gas		

SABROE HEAT PUMPS

	HeatPAC recip Water up to 90°C Heating capacity: 300 – 2,700 kW Recip compressor, variable speed only, Ammonia (R717) (<50 kg charge)	  
	HyePAC Heat Pump Water up to 120°C Heating capacity: 300 – 2,000 kW Recip compressor, variable speed drive, Ammonia (R717) + Water (R718)	   
	DualPAC Water up to 90°C Heating capacity: 400 – 2,900 kW Variable speed, Ammonia (R717)	  
	HicaHP Water up to 95°C Heating capacity: up to 7,000 kW Screw compressor, fixed or variable speed, Ammonia (R717)	  
	HitemHP Water up to 125°C Heating capacity: 150 – 1,200 kW Recip compressor, single-stage, low-pressure, hydrocarbons (HCs)	   

SABROE INDUSTRIAL REFRIGERATION

RECIPROCATING COMPRESSOR		 
	CMO Capacity: 100 – 270 kW Fixed or variable speed, Ammonia (R717), hydrocarbons (HCs), common HFCs and derived blends	
	SMC Capacity: 270 – 1,430 kW Fixed or variable speed, Ammonia (R717), hydrocarbons (HCs), common HFCs and derived blends	 
	HPO/HPC/HPX Heating capacity: 330 – 3,200 kW Fixed or variable speed, Ammonia (R717), carbon dioxide (R744), hydrocarbons (HC), common HFCs and derived blends	 
	SCREW COMPRESSOR SAB, small / SAB, large Capacity: 180 – 7,000 kW Fixed or variable speed, Ammonia (R717), carbon dioxide (R744), hydrocarbons (HCs), common HFCs and derived blends	 
	AIR-COOLED CHILLER ChillPAC Air Cooling capacity: 260 – 1,400 kW Recip compressor, fixed or variable speed, Ammonia (R717)	 
	WATER-COOLED CHILLERS ChillPAC Cooling capacity: 100 – 1,400 kW Recip compressor, fixed or variable speed, Ammonia (R717) (<50 kg charge)	 
	CompAC Cooling capacity: 200 – 2,300 kW Screw compressor, fixed or variable speed, Ammonia (R717) (low charge)	 
	PAC screw or recip Cooling capacity: 100 – 7,000 kW Screw or Recip compressor, fixed or variable speed, Ammonia (R717)	  
	CAFP low-temperature chiller Capacity: 85 – 790 kW Fixed or variable speed, Ammonia/CO ₂ (R717/R744)	  
VESSEL AND EXCHANGER		
VESSEL PROGRAM Separators, Intercoolers, Receivers and Air Purgers. Standard product range. Inhouse design and engineering department. PED, EAC, DNV, LRS, BV, ABS, MOM, DOSH, KGS, KR		
EXCHANGER PROGRAM Shell and tube design Condensers, Evaporators and Cascade Units. Capacity range from 50kW to 5000kW		
CONTROLS		
UniSAB 4 Integrated systems controller for chillers and heat pumps		
Chiller and Heat Pump Plant Controller Plug-and-play control panel for plant integration of chillers and heat pumps		
ISAC Monitoring and control interface configuration system for refrigeration installations		



*** AHRI CERTIFICATION PROGRAM**

YORK chillers have been tested and certified by Air-Conditioning, Heating and Refrigeration Institute (AHRI) in accordance with the latest edition of AHRI Standard 551/591 (S-I). Under this Certification Program, chillers are regularly tested in strict compliance with this Standard. This provides an independent, third-party verification of chiller performance. Refer to the following AHRI site at <https://www.ahrinet.org/certification/ahri-certification-programs> for air-cooled and water-cooled Program Scope, Inclusions, and Exclusions as some options listed herein fall outside the scope of the AHRI certification program. For verification of certification, go to the AHRI Directory at www.ahridirectory.org

Catalogue content

Chillers and Heat Pumps	
YMAE Air-to-Water Inverter Scroll Heat Pump NEW	16
Amichi Series Air cooled Scroll DC Inverter reversible heat pump	22
YLPB Heat pump scroll compressor	30
YCPB Heat pump scroll compressor NEW	34
YTH Air to Water Reversible Heat Pump with Scroll compressors	42
YTL Air to Water Reversible Heat Pump with Scroll compressors NEW	44
YTL Air to Water Reversible Heat Pump with Screw compressors NEW	46
YCH 4-Pipe Multifunctional units with Scroll compressors and plate exchangers	48
YCH 4-Pipe Multifunctional units with Inverter Screw compressors, EC Inverter fans and shell and tube exchangers	50
YHA High efficiency air to water heat pumps	52
YLZ High efficiency air to water heat pumps with E.V.I. compressors	54
YLAA Air-cooled scroll compressor chiller	58
YGT Air-cooled VSD screw chiller with HFO	60
New generation YVAA Air-cooled VSD screw chiller	62
YVFA Air-cooled VSD screw chiller with integrated Free-cooling	70
YVAM Air-Cooled Magnetic Bearing Centrifugal Chiller NEW	76
YAS / Rc-MC Air-cooled liquid chiller with reciprocating compressor, axial fans and refrigerant R290 (Propane)	84
YAS / Rc-WP Air-cooled heat pump with reciprocating compressor, axial fans and refrigerant R290 (Propane)	94
YMWA / YMRA Water-cooled reversible heat pump with scroll compressor	100
YRW Water-cooled screw compressor chiller	102
YCSE / YCRE Style C Water-cooled screw compressor chiller	104
YWH Super-high temperature water to water scroll heat pumps	106
YWW Water-cooled chillers and heat pumps with Scroll compressors	108
YWW Water-cooled chillers with Screw compressors	110
YVWH Premium-Efficiency VSD water-cooled screw compressor chiller	112
YVWH HP Premium-Efficiency VSD water-cooled screw compressor heat pump	116
YZ Magnetic bearing centrifugal chiller	118
YMC ² Water-cooled magnetic centrifugal chiller	122
YK Water-cooled centrifugal chiller	124
Water cooled custom offering	126
YORK Absorption chillers and heat pumps	128
YHAP Absorption heat pump	136
YHAU-CL/CH Single effect hot water driven absorption chiller	142
YHAU-CL/CH-DXS Single effect double lift hot water driven absorption chiller	144
YHAU-CL/CH-B Single effect hot water driven absorption chiller (Mod B)	146
WFC SC Single stage hot water absorption chiller	148
OpenBlue Central Utility Plant (CUP)	150
OpenBlue Connected Chillers Services	152
Heat Pump Solutions	154
HVAC Fundamentals	158
Ecodesign Directive for HVAC Chillers and Heat Pumps	164
Air Handling Systems and Terminal Devices	
YMA Custom air handling units	174
YMB Semi-customized Air Handling Units	176
YMD Standard Air Handling Units	178
YMB-SP Air Handling Units for private and public swimming pools	182
YMF Packaged Air Handling Units with Heat Pump	184
YBV-NG Compact Suspended Air Handling Units NEW	186
YBV-NG Compact Floor Mounted Air Handling Units NEW	190
YBV-NG Compact TOP Floor Mounted Air Handling Units NEW	200
YKR Compact Air Handling Units with Rotary Heat Exchanger	204
YKC Compact Air Handling Units with Counterflow Plate Heat Exchanger	206
YKL Compact Low Profile Air Handling Unit with Counterflow Plate Heat Exchanger	208
YKH Residential Type Heat Recovery Unit with Plastic Counterflow Plate Heat Exchanger	210
YKH2G Residential Ventilation Heat Recovery Units with Counterflow Plate Heat Exchange NEW	212
YEPR Heat Recovery Units	214
Rooftop Equipment	
ACTIVA Rooftop ARC-ARG-ARH-ARD 017 to 040 AB / BB	218
ACTIVA AGR Rooftop AGR 019 to 040	222
ACTIVA ASR Rooftop ASR 50 to 210	224
Large ACTIVA Rooftop ARC-ARH 100 to 175 AB	228
Terminal Devices	
YFCN Fan Coil Unit with centrifugal fan / YFCN-ECM Inverter Fan Coil Unit with centrifugal fan	234
YFTS-ECM Inverter Fan Coil Unit with tangential fan	244
LASER and LOW BODY Fan Coil Units / LASER ECM and LOW BODY ECM Inverter Fan Coil Units	248
YHPL High static pressure blower / YHPL-ECM Inverter high static pressure blower	258
RFHP-O High static pressure blower / RFHP-O-ECM Inverter high static pressure blower	264
YGFC Medium static pressure blower	268
YDFC High static pressure blower	272
YEFB High static pressure blower / YEFB-ECM Inverter high static pressure blower	274
YKEY and YKEY900 Hydro Cassette / YKEY-ECM and YKEY900-ECM Inverter Cassette	280
YHK Hydro Cassette / YHK-ECM Inverter Hydro Cassette	286
YHVP Hydro High Wall / YHVP-ECM Inverter Hydro High Wall	292
YORK YC-P / YC-G / YC-R / YC-H Series Close Control Air Conditioners	298
YC-W Series Fan Wall Units	314
Factory fitted controls	316
Comprehensive Solutions	
Verasys Configurable building controls system for smarter buildings	320
EasyIO®	322
Metasys® Upgrades, Migrations and Subscriptions (MUMS)	324
Tailored Service Solutions for HVAC	326
Solution Navigator	330



Air-Cooled Chillers and Heat Pumps

YORK offers a complete range of air-cooled chiller and heat pumps within **18 kW to 4000 kW capacities**, to cover all customer needs, maintaining the highest efficiency levels and operative performances.

YORK Chillers Units

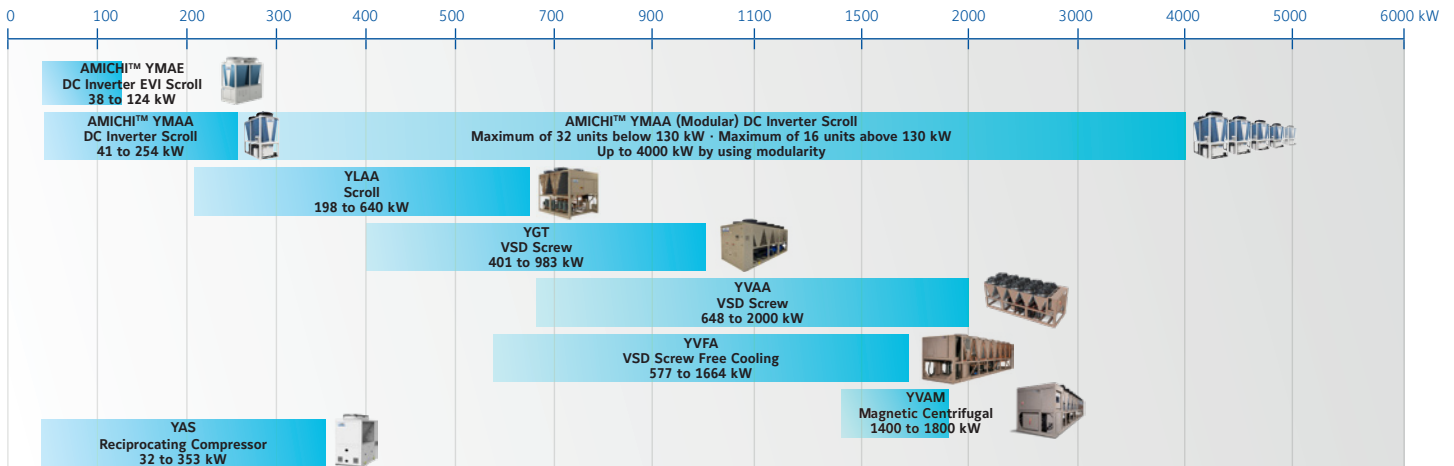

YORK Heat Pump Units

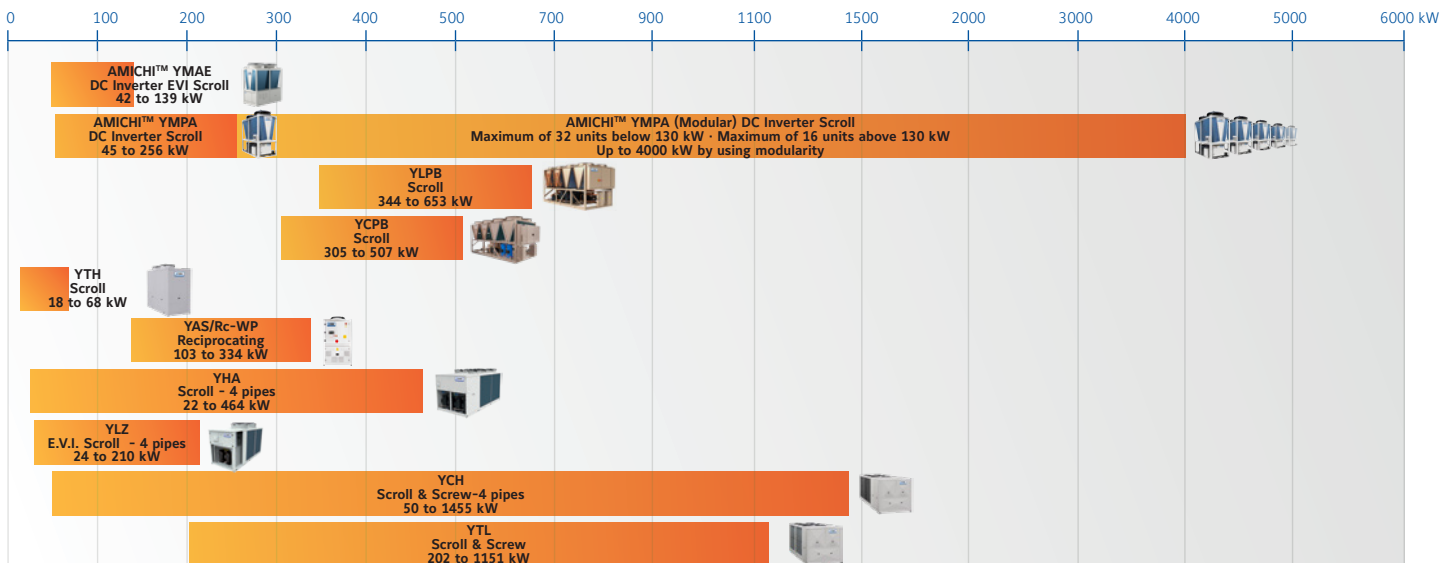

Three different compressor technologies for to meet the most challenging requirements

Scroll compressor
YMPA, YLAA, YLPB, YTH, YHA, YLZ

A **scroll compressor** is typically used in small-medium size HVAC applications for residential and commercial buildings. It offers a good compromise between a compact footprint and wide operating envelope. A typical application is a multi-compressor system, often with one inverter compressor for more flexible regulation and improved efficiency.

Screw compressor
YGT, YVAA, YVFA, YCH, YTL, YVAM

A **rotary-screw compressor** uses a rotary-type positive-displacement mechanism. Screws are commonly used for medium size comfort, process cooling or data center applications where high compression ratios and lift are required, such as for glycol or dry cooler operation.

Variable compression ratio (Vi) and slide valve can provide the best efficiency while matching the different operating conditions required by each application.

Reciprocating compressor
YAS, YAS-WP

A **reciprocating compressor** type optimized to operate with the hydrocarbons and realized in compliance with the safety regulation in force. The electrical motor, arranged for starts with low inrush current (PW option), is equipped with thermal protection module (installed in the electrical cabinet); the lubricating system, of forced type, is equipped with oil filters and check valves to survey the lubricating pressure and is made through a high pressure pump.



YMAE Air-to-Water Inverter Scroll Heat Pump

0045 to 0130

A complete range from 38 kW up to 124 kW



Efficiency-optimized heating and cooling for best-in-class performance

The YORK YMAE Air-to-Water Inverter Scroll Heat Pump is designed to meet tomorrow's efficiency standards today. Delivering performance beyond typical efficiency levels, this heat pump boasts an industry-leading part-load SCOP up to 4.24 according to EN14825. This exceeds stringent regulatory requirements through an optimized combination of efficiency-enhancing technologies from Johnson Controls.

The unit is equipped with full DC inverter EVI compressors, EC fan motors and YORK inverter drivers, and is able to meet stepless adjustment needs within the capacity range of 19-100 percent, allowing them to accurately match the required building load. The modules do not need to be started and stopped frequently, resulting in a smooth and stable operation, while the user-side temperature control is more accurate, further enhancing user comfort.

Wide operation range

YMAE is a no-compromise solution for a variety of climates and locations. Built specifically to deliver better performance through a wider operating envelope, this heat pump can maintain efficiency in a variety of conditions without kits or add-ons – up to 48°C ambient in cooling mode and down to an impressive -25°C ambient in heating mode and be capable of providing the chilled leaving water temperature down to -12°C and hot water up to 60°C. The applicability of an air-to-water heat pump is dependent on its ability to deliver sufficient heat output when it's cold outside. The YMAE excels in this area, offering the widest operating map to deliver as much as 20 percent more heating capacity at low ambient operation.

Quiet operation and multiple applications

YMAE is excellent in keeping the extremely low noise level not only in partial load but also in full load thanks to the full DC inverter technologies and the intelligent adaptive operating control logics.

The excellent performance on working range of ambient temperature, ultra-low operating noise level and flexible modular combination, YMAE is flexibly applied to a variety of occasions to meet the needs of different scenarios.



Best-in-class efficiency



Wide operation range



Quiet operation



Robust reliability



Sustainability

Air-to-Water Inverter Scroll Heat Pump

YMAE 0045 to 0130



Standard sound unit

Model			YMAE0045	YMAE0050	YMAE0065	YMAE0130
Cooling	Cooling Capacity	kW	43.5	50.0	60.0	124.0
	Power input	kW	14.8	15.9	21.3	42.5
	EER	kW/kW	2.94	3.15	2.82	2.92
	SEER	kW/kW	4.65	4.64	4.50	4.70
	$\eta_{s,c}$	%	183.1	182.8	177.2	185.2
	Sound power level	dB(A)	80	79	82	83
Heating	Heating Capacity	kW	48.0	53.0	60.5	139.0
	Power input	kW	15.6	15.6	18.7	43.4
	COP	kW/kW	3.08	3.40	3.23	3.20
	SCOP	kW/kW	4.10	4.22	4.10	4.06
	$\eta_{s,h}$	%	161.0	165.6	161.1	159.4
Refrigerant	Type		R454B			
	Circuit quantity	#	1	1	1	2
	Refrigerant charge/circuit	kg	10.0	10.5	10.5	11.5
Compressor	Type		DC inverter scroll with EVI			
	Capacity step		Stepless (Inverter)			
	Quantity		1	1	1	2
Air side heat exchanger	Coil type		Copper Tube, Aluminum Plate Fin			
	Fan type		Axial fan, BLDC motor			Axial fan, EC inverter motor
	Fan quantity		2			
	Outdoor air temp range (cooling)	°C	-15 ~ 48		-20 ~ 48	
	Outdoor air temp range (heating)	°C	-25 ~ 43			
Water side heat exchanger	Type		Brazen plate heat exchanger			
	Water connection		External thread	External thread	External thread	Victaulic
	Size of water pipe		G2"	G2"	G2"	DN65
	Nominal water flow rate (cooling)	l/s	2.08	2.39	2.87	5.92
	Nominal water flow rate (heating)	l/s	2.29	2.53	2.89	6.64
	Pressure drop (cooling)	kPa	42	36	50	50
	Pressure drop (heating)	kPa	50	40	51	58
	Leaving water temp range (cooling)	°C	-12 ~ 20			
	Leaving water temp range (heating)	°C	25 ~ 55	25 ~ 60	25 ~ 60	25 ~ 60
Dimensions	Height	mm	1700	1700	1700	2420
	Length	mm	1650	1650	1650	2240
	Width	mm	760	760	760	1200
Weight	Shipping weight	kg	545	560	560	1075
	Operating weight	kg	480	502	502	1090
Electrical	Power supply	V/Ph/Hz	400V - 3Ph - 50Hz			

1. Net values at Eurovent nominal conditions:

- Cooling capacities in kW given for 7°C leaving water temperature $\Delta t_5^\circ\text{C}$ and 35°C ambient temperature.
- Heating capacities in kW given for 45°C leaving water temperature $\Delta t_5^\circ\text{C}$ and 7°C ambient temperature.
- SEER and SCOP are calculated according to EN14511 and EN14825.
- η_s is calculated according to Ecodesign regulation for chillers comfort cooling and heating (813/2013, 2016/2281)

2. SEER is calculated following fixed water flow and variable outlet approach (FW/VO) .

SCOP is calculated following variable water flow and variable outlet approach (VW/VO).

For other Ecodesign calculations, please contact your JCI representative.



Manufacturer reserves the rights to change specifications without prior notice.

Air-to-Water Inverter Scroll Heat Pump

YMAE 0045 to 0130



Low sound unit

Model			YMAE0045	YMAE0050	YMAE0065	YMAE0130
Cooling	Cooling Capacity	kW	38.0	45.0	54.0	118.0
	Power input	kW	11.4	13.9	18.4	38.1
	EER	kW/kW	3.32	3.23	2.93	3.10
	SEER	kW/kW	4.70	4.67	4.61	4.86
	$\eta_{s,c}$	%	185.3	184.0	181.4	191.3
	Sound power level	dB(A)	75	75	77	79
Heating	Heating Capacity	kW	41.5	49.0	54.0	128.0
	Power input	kW	12.2	13.9	15.9	39.1
	COP	kW/kW	3.41	3.53	3.39	3.27
	SCOP	kW/kW	3.97	4.24	4.20	3.94
	$\eta_{s,h}$	%	156.0	166.6	165.1	154.5
Refrigerant	Type		R454B			
	Circuit quantity	#	1	1	1	2
	Refrigerant charge/circuit	kg	10.0	10.5	10.5	11.5
Compressor	Type		DC inverter scroll with EVI			
	Capacity step		Stepless (Inverter)			
	Quantity		1	1	1	2
Air side heat exchanger	Coil type		Copper Tube, Aluminum Plate Fin			
	Fan type		Axial fan, BLDC motor			Axial fan, EC inverter motor
	Fan quantity		2			
	Outdoor air temp range (cooling)	°C	-15 ~ 48		-20 ~ 48	
	Outdoor air temp range (heating)	°C	-25 ~ 43			
Water side heat exchanger	Type		Braze plate heat exchanger			
	Water connection		External thread	External thread	External thread	Victaulic
	Size of water pipe		G2"	G2"	G2"	DN65
	Nominal water flow rate (cooling)	l/s	1.82	2.15	2.58	5.64
	Nominal water flow rate (heating)	l/s	1.98	2.34	2.58	6.12
	Pressure drop (cooling)	kPa	33	30	42	38
	Pressure drop (heating)	kPa	39	35	42	48
	Leaving water temp range (cooling)	°C	-12 ~ 20			
Leaving water temp range (heating)	°C	25 ~ 55	25 ~ 60	25 ~ 60	25 ~ 60	
Dimensions	Height	mm	1700	1700	1700	2420
	Length	mm	1650	1650	1650	2240
	Width	mm	760	760	760	1200
Weight	Shipping weight	kg	545	560	560	1079
	Operating weight	kg	480	502	502	1093
Electrical	Power supply	V/Ph/Hz	400V - 3Ph - 50Hz			

- Net values at Eurovent nominal conditions:
 - Cooling capacities in kW given for 7°C leaving water temperature $\Delta t5^\circ\text{C}$ and 35°C ambient temperature.
 - Heating capacities in kW given for 45°C leaving water temperature $\Delta t5^\circ\text{C}$ and 7°C ambient temperature.
 - SEER and SCOP are calculated according to EN14511 and EN14825.
 - η_s is calculated according to Ecodesign regulation for chillers comfort cooling and heating (813/2013, 2016/2281)
- SEER is calculated following fixed water flow and variable outlet approach (FW/VO).
 SCOP is calculated following variable water flow and variable outlet approach (VW/VO).
 For other Ecodesign calculations, please contact your JCI representative.



Manufacturer reserves the rights to change specifications without prior notice.

Exceeds efficiency standards

The **YORK YMAE Air-to-Water Inverter Scroll Heat Pump** is designed to meet tomorrow's efficiency standards today. Delivering performance beyond typical efficiency levels, this heat pump boasts an industry-leading **SCOP up to 4.24** according to EN14825.

This exceeds stringent regulatory requirements through an optimized combination of efficiency-enhancing technologies from Johnson Controls.

YMAE	YMAE is at the top of its class	
SEER	Up to 4.86	Exceed the Ecodesign Tier 2 standard by 19%
SCOP	Up to 4.24	Exceed the Ecodesign Tier 2 standard by 32%

High-efficiency DC inverter scroll compressor with EVI

YMAE Series uses the proven design of the direct current (DC) inverter compressor, which embraces all of the design features driven for exceptional efficiency all year around. It deliver stepless capacity control from 19% to 100%, allowing precise capacity matching for building loads and reducing unit power input, resulting in a significant energy consumption savings for the chiller and heat pump system.

New asymmetric wrap: Optimized design reduces leakages and invalid suction superheating.

Non-contact seal design: Oil film seal formed by lubricating oil to reduce friction for higher efficiency and reliability.

Relieve valve: More adaptive to variable pressure conditions to provide higher part-load efficiencies.

Enhanced Vapor Injection (EVI) technology: Significantly extends compressor operation map and increases efficiency.

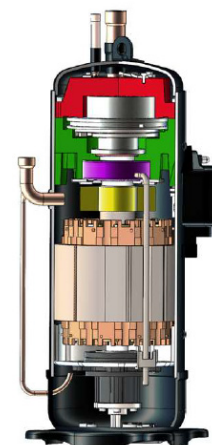
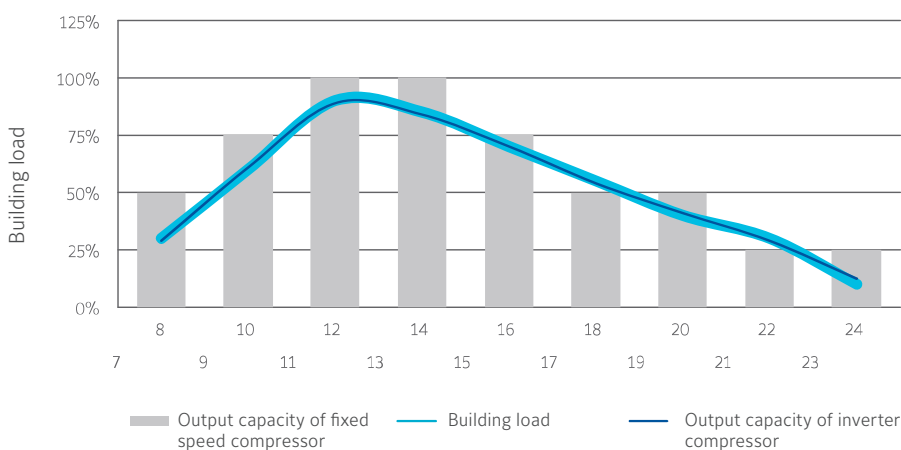



YORK inverter driver

The YORK inverter driver is engineered to meet the challenging performance demands of the YMAE chiller. Coupled with smart control logic, the solution smartly manages system operation and ultimately delivers excellent energy savings throughout entire life cycle for the customer.

YMAE Operating Range

YMAE0045

Cooling mode

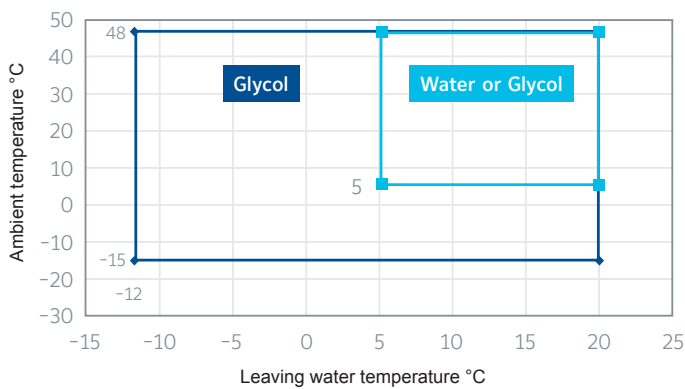

Heating mode

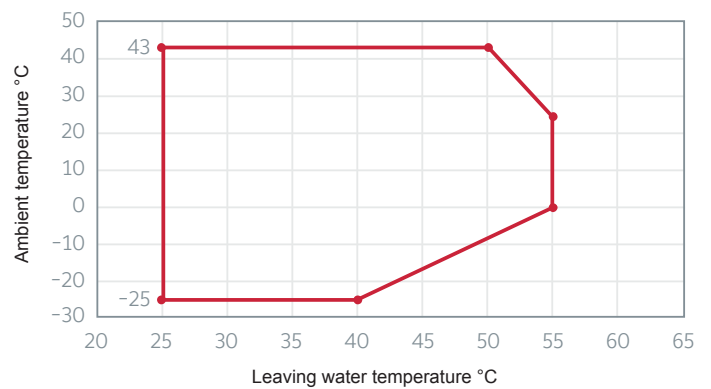

YMAE0065 to 0130

Cooling mode

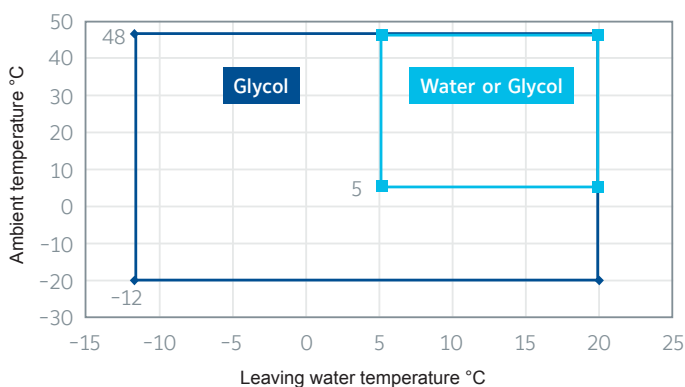

Heating mode

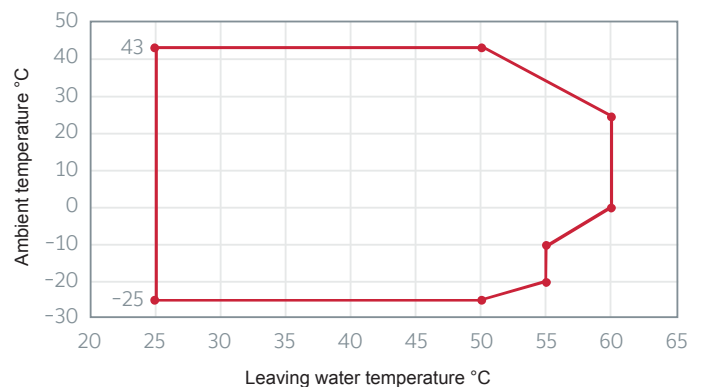

Dimensions and hydraulic connections

YMAE0045/0050/0065

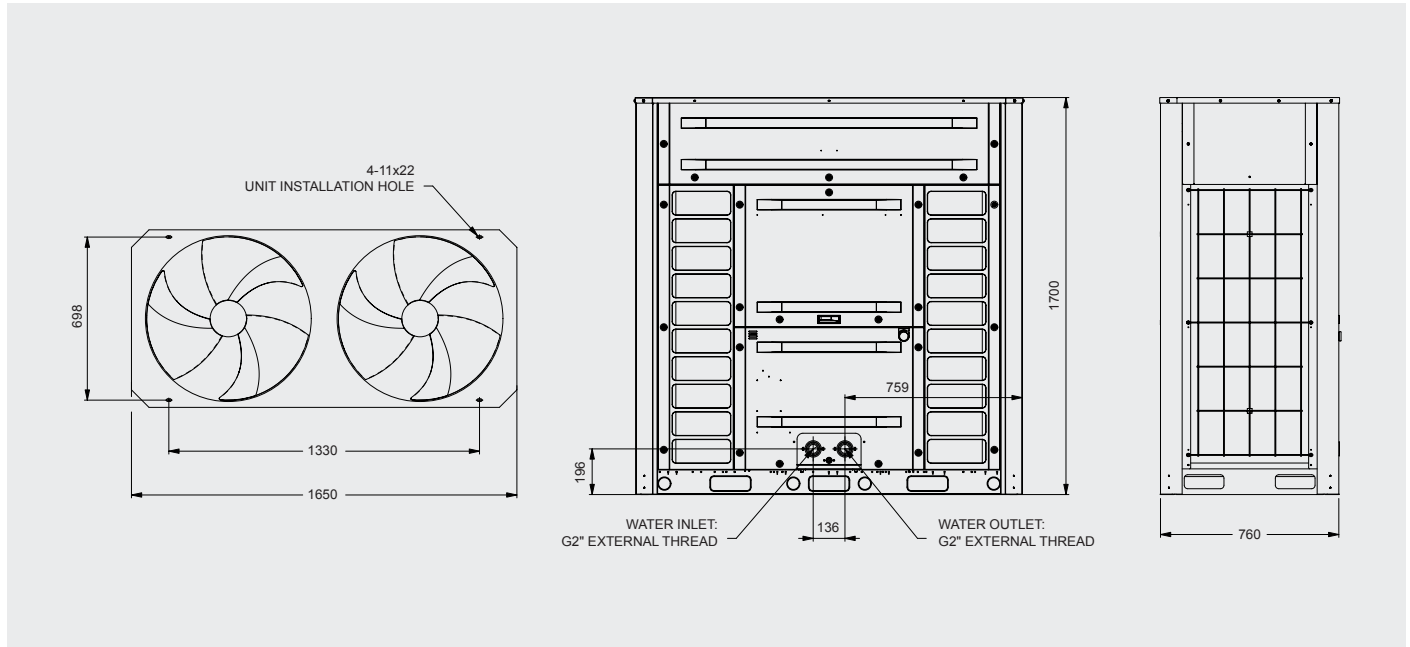

YMAE0130

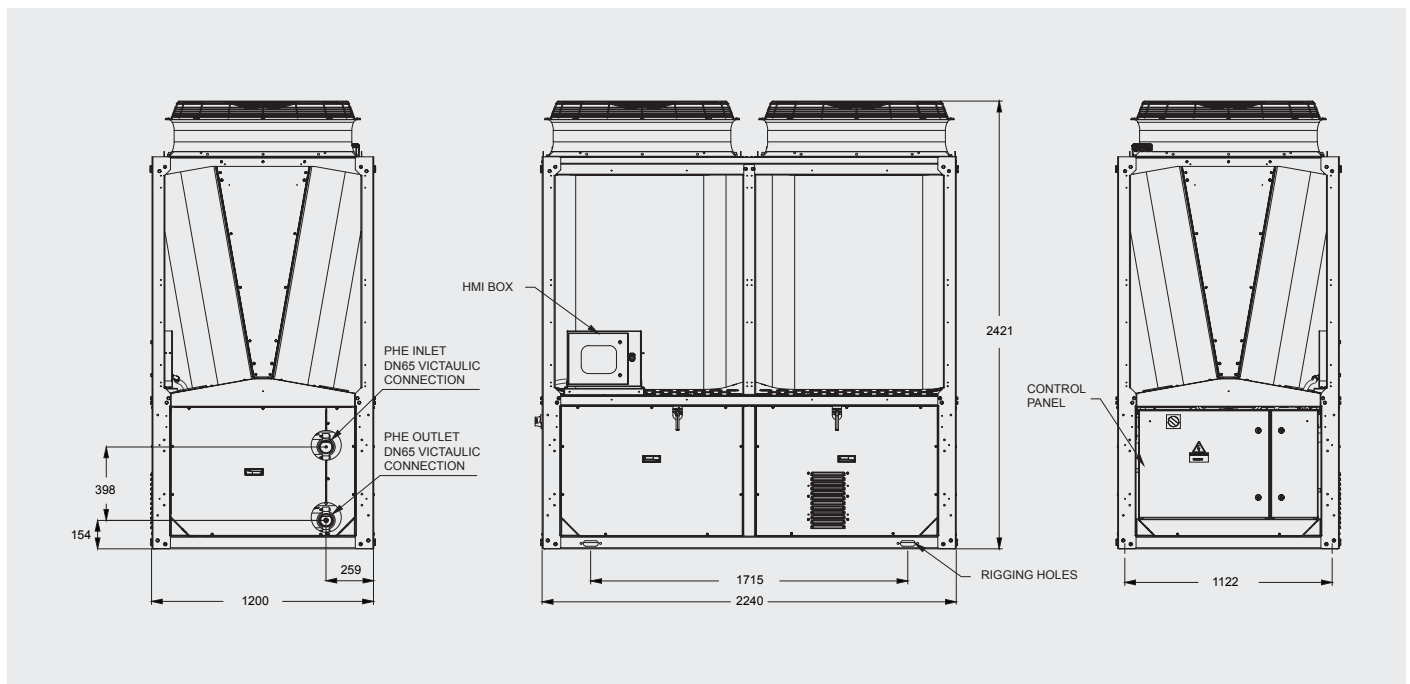

Amichi Series

Air cooled Scroll DC Inverter reversible heat pump

YMPA 0045 to 0260

A complete range from 40 kW up to 250 kW



Heat Pump Product of the Year
WINNER ACR AWARDS 2021

Exceeding Efficiency Standards

The YORK® Amichi Series Air-Cooled DC Inverter Scroll Chillers and Heat Pumps have been designed to meet tomorrow's efficiency standards today. Delivering performance beyond typical chiller and heat pump efficiency levels, the YORK® Amichi Series meets or exceeds stringent regulatory requirements (see chart below) through an optimized combination of efficiency-enhancing technologies from YORK®.

ECODESIGN REGULATIONS CATEGORY:	EFFICIENCY METRIC:	TOMORROW'S STANDARDS MET TODAY:
Comfort Heating	SCOP/ηsh	Amichi Heat Pump: Sept. 2017 Compliant (Tier 2)
Comfort Cooling	SEER/ηsc	Amichi Chiller: Jan. 2021 Compliant (Tier 2)
Process Cooling (Med. Temp.)	SEPR	Amichi Chiller: July 2018 Compliant (Tier 2)
Process Cooling (High Temp.)	SEPR	Amichi Chiller: Jan. 2021 Compliant (Tier 2)

Performance Without Compromise

The YORK® Amichi Series is a no-compromise solution for a variety of climates and locations. It can maintain efficiency in a variety of conditions without kits or add-ons (down to -18°C ambient in cooling mode and -15°C ambient in heating mode). With the smallest footprint across the widest capacity range on the market, the YORK® Amichi Series is also the perfect solution for high performance in smaller spaces. Our systems offer two levels of sound performance. If requirements call for sound attenuation beyond our standard low-noise levels, an optional Ultra Quiet Kit can further reduce sound power by 6 dBA, providing one of the quietest units available.

Modular system - Greater design flexibility

- 9 package models or modular combinations
- Controls can be parent/child controller if application requires
- Maximum of 32 units below 130 kW
- Maximum of 16 units above 130 kW

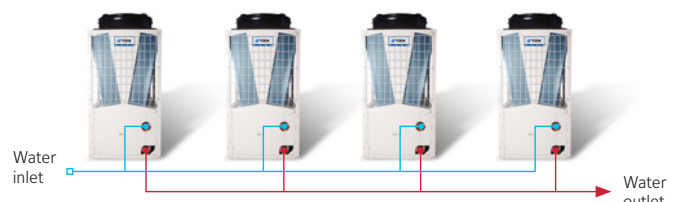

Air cooled Scroll DC Inverter reversible heat pump

YMPA 0045 to 0260



YMPA 45 to 260 PJ - technical features for R454B Standard unit

Model			YMPA								
			0045	0065	0080	0100	0130	0160	0200	0230	0260
Performance	Cooling capacity h/p units	kW	43	59	76	97	119	156	184	217	248
	EER		3.03	2.95	3.28	3.17	3.12	3.30	3.22	3.27	3.26
	SEER		4.78	4.88	4.43	4.93	4.47	4.69	4.49	4.74	4.78
	ηs,c		188.2	192.0	174.2	194.3	176.0	184.7	176.6	186.5	188.2
	Sound power level	dB(A)	79	81	80	82	83	85	86	86	87
	Heating capacity h/p units @35°C	kW	50	60	89	103	132	165	193	234	260
	COP @35°C		3.80	3.76	4.11	4.10	3.75	4.23	4.11	4.17	4.12
	SCOP		3.73	3.71	3.71	3.72	3.75	3.72	3.71	3.72	3.71
	ηs,h		146.4	145.6	145.4	145.7	147.1	146.0	145.5	146.0	145.0
	Heating capacity h/p units @45°C	kW	49	60	87	98	131	160	189	229	254
COP @45°C		3.05	3.06	3.29	3.23	2.95	3.31	3.25	3.26	3.25	
Refrigerant	Refrigerant circuits	#	1	1	2	2	2	3	3	4	4
	Refrigerant charge (R454B)	kg	8	10.8	16	18	20	26.3	28.7	38	40
Compressor	Type		DC Scroll Inverter + Scroll								
	Capacity steps	%	Stepless (Inverter)								
	Quantity		2	2	3	3	4	5	6	7	8
Air side heat exchanger	Fan motor type		EC motor								
	Fans quantity		1	1	2	2	2	3	3	4	4
	Working ambient temp. cooling mode		-18 ~ 48°C								
	Working ambient temp. heat. mode		-15 ~ 25°C								
Water side heat exchanger	Type		Plate Heat Exchanger								
	Unit water volume (w/o pump kit)	l	9	10	11	14	15	27	29	32	34
	Pump Type		Fixed / Variable Speed Drive Pump				Variable Speed Drive Pump				
	Nominal water flow	l/s	2.1	2.8	3.6	4.7	6.3	7.4	8.8	10.4	11.8
	Pressure drop (cooling)	kPa	31	24	26	29	39	24	31	39	36
	Working range water leaving temp. cooling		-12 ~ 20°C								
	Working range water leaving temp. heating		25 ~ 55°C								
	Water connections type		Victaulic								
Dimensions and weight	Height (w/o pump kit)	mm	2440				2500				
	Width (w/o pump kit)	mm	1200				3050				
	Depth (w/o pump kit)	mm	1500		2240						
	Operating weight (w/o pump kit)	kg	687	715	1024	1036	1136	1922	2084	2312	2434
Electrical	Voltage/Phases/Frequency	V/ph/hz	400/3/50+E								

Net values at Eurovent nominal conditions:

Cooling capacities given for 7°C water leaving temperature Δt 5°C and 35°C ambient temperature.

Heating capacities given for 7°C ambient temperature.

SEER and SCOP calculated according to EN14511 and EN14825.

ηs calculated according to Ecodesign regulation for chillers comfort cooling and heating (813/2013, 2016/2281).

Ecodesign figures are calculated following fixed water and variable outlet approach (FW/VO). For other Ecodesign calculations, please contact your JCI representative.

The above data is based on Johnson Controls' selection software YORKworks 21.10b. Please refer to the latest version of the software for specific projects.



Manufacturer reserves the rights to change specifications without prior notice.

Air cooled Scroll DC Inverter reversible heat pump

YMPA 045 to 260



YMPA 45 to 260 PJ - technical features for R454B Low sound unit

Model			YMPA								
			0045	0065	0080	0100	0130	0160	0200	0230	0260
Performance	Cooling capacity h/p units	kW	40	55	73	90	115	154	177	210	240
	EER		3.03	3.01	3.23	3.17	3.06	3.17	3.09	3.09	3.10
	SEER		4.72	4.65	4.23	4.81	4.30	4.47	4.41	4.74	4.89
	$\eta_{s,c}$		185.7	182.9	166.3	189.5	169.0	175.6	173.6	186.5	192.6
	Sound power level	dB(A)	73	76	76	77	79	80	81	81	82
	Heating capacity h/p units @35°C	kW	46	55	85	95	115	158	183	226	239
	COP @35°C		4.00	3.98	4.23	4.25	3.34	4.23	4.17	4.18	4.30
	SCOP		3.61	3.63	3.58	3.55	3.57	3.74	3.72	3.58	3.50
	$\eta_{s,h}$		141.4	142.4	140.4	139.0	139.8	146.5	145.8	140.2	137.0
	Heating capacity h/p units @45°C	kW	45	55	83	91	115	155	180	222	243
COP @45°C		3.17	3.21	3.34	3.27	2.60	3.30	3.28	3.26	3.28	
Refrigerant	Refrigerant circuits	#	1	1	2	2	2	3	3	4	4
	Refrigerant charge (R454B)	kg	8	10.8	16	18	20	26.3	28.7	38	40
Compressor	Type		DC Scroll Inverter + Scroll								
	Capacity steps	%	Stepless (Inverter)								
	Quantity		2	2	3	3	4	5	6	7	8
Air side heat exchanger	Fan motor type		EC motor								
	Fans quantity		1	1	2	2	2	3	3	4	4
	Working ambient temp. cooling mode		-18 ~ 48°C								
	Working ambient temp. heat. mode		-15 ~ 25°C								
Water side heat exchanger	Type		Plate Heat Exchanger								
	Unit water volume (w/o pump kit)	l	9	10	11	14	15	27	29	32	34
	Pump Type		Fixed / Variable Speed Drive Pump				Variable Speed Drive Pump				
	Nominal water flow	l/s	1.9	2.6	3.5	4.3	5.5	7.4	8.4	10.0	11.5
	Pressure drop (cooling)	kPa	27	21	24	25	32	23	29	37	34
	Working range water leaving temp. cooling		-12 ~ 20°C								
	Working range water leaving temp. heating		25 ~ 55°C								
	Water connections type		Victaulic								
Dimensions and weight	Height (w/o pump kit)	mm	2440				2500				
	Width (w/o pump kit)	mm	1200				3050				
	Depth (w/o pump kit)	mm	1500				2240				
	Operating weight (w/o pump kit)	kg	687	715	1024	1036	1136	1922	2084	2312	2434
Electrical	Voltage/Phases/Frequency	V/ph/hz	400/3/50+E								

Net values at Eurovent nominal conditions:

Cooling capacities given for 7°C water leaving temperature Δt 5°C and 35°C ambient temperature.

Heating capacities given for 7°C ambient temperature.

SEER and SCOP calculated according to EN14511 and EN14825.

η_s calculated according to Ecodesign regulation for chillers comfort cooling and heating (813/2013, 2016/2281).

Ecodesign figures are calculated following fixed water and variable outlet approach (FW/VO). For other Ecodesign calculations, please contact your JCI representative.

The above data is based on Johnson Controls' selection software YORKworks 21.10b. Please refer to the latest version of the software for specific projects.



Manufacturer reserves the rights to change specifications without prior notice.

Advanced Control Made Easy

Comfort, productivity, and up to half of the energy used in your building – these are all factors affected by how your chiller operates and how it interacts with other components in your HVAC/R system. To help maximize efficiency and keep you in control, the YORK® Amichi Series comes as standard with integrated Smart Equipment. This technology allows the equipment to connect seamlessly to building controls, such as our world-class Verasys™ system, where smart-enabled equipment can self-identify and interoperate.

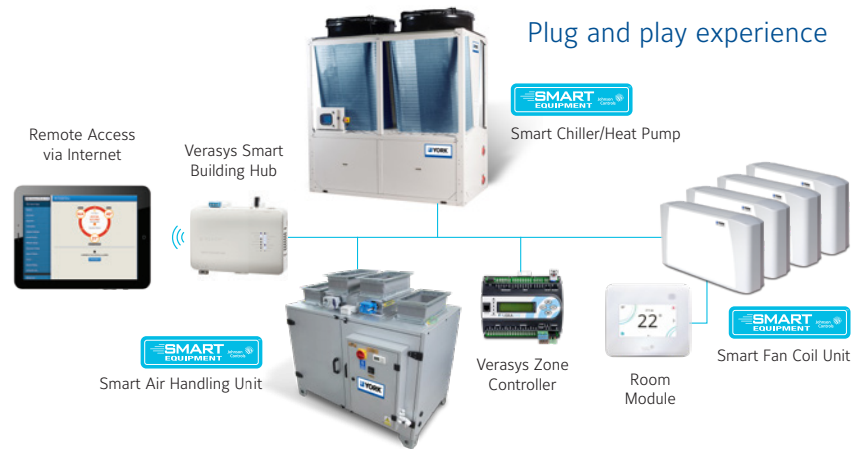

Perfect solution for rental application

- Ambient operating range in cooling mode from -18 to 48°C
- Outstanding minimum leaving fluid temperature, down to -12°C
- Power quick connector CEE17 for main power (400/3/50, 3P+G) and 220V compressor heater (in chiller panel)
- Water quick connector Camlock (EN14420-7)
- Gate valves for water inlet/outlet connections
- Condenser coil: Gold fin pre-coating and wire mesh around coil

- Chiller IP54 and control panel IP55
- Low Sound compressor enclosure
- Available ESP up to 200 kPa at standard conditions
- Rental Panel (by request)
- Connected Service Kit (by request)
- Perfect solution for Ice-Rink rental applications

Note: please contact your JCI representative for getting your special quotation

Safety is our priority

The YORK® Amichi Series Air-Cooled DC Inverter Scroll Heat Pump is designed for safe operation. The new R454B refrigerant was chosen with safety and low toxicity in mind.

R454B has a 78 percent lower GWP value in comparison to R410A and is classified in safety class A2L (non-toxic and difficult to ignite).

This heat pump is equipped with refrigerant leakage sensors, additional switch cabinet ventilation, and software management for leak warning messages. With multiple functional and reliability tests, quality assurance is enhanced.

To maximise safety, the system design has been verified by a third-party certification body to increase customer peace of mind. The customized components together with our advanced technology, give absolute confidence.

		Refrigerants Safety Groups	
Flammability	Higher	A3	B3
	Lower	A2	B2
	Difficult to Ignite and Sustain	A2L	B2L
	No Flame Propagation	A1	B1
		Lower	Higher
		No identified toxicity at concentrations ≤ 400 ppm	Evidence of toxicity below 400 ppm
		Toxicity	

Source: ASHRAE Standard 34 Safety Classification



Customized hermetic scroll compressors designed for A2L refrigerant



Optimized plate heat exchanger, suitable for R454B application



A ventilation system installed inside the unit to ensure no A2L gas accumulates



Leakage detective sensor equipped to detect any gas leakage



Amichi Series

Air cooled Scroll DC Inverter reversible heat pump

Main features

EC Fans

- High efficiency
- Low sound level
- Up to 50Pa available static pressure



Hydronic Kit

- Single fix speed pump hydronic kit or with variable speed **VSD**
- External available pressure up to **100 kPa (10m)** for fix speed pump
- External available pressure up to **150 kPa (15m)** for VSD pump

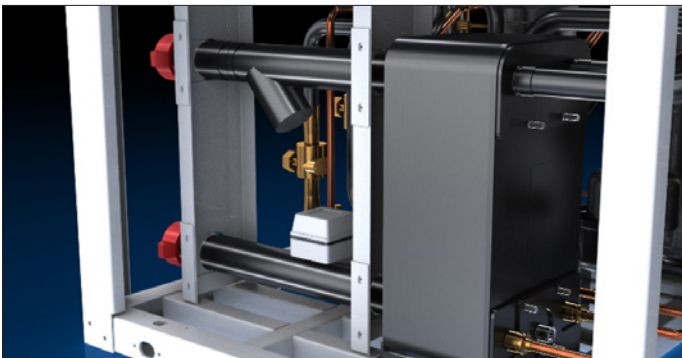
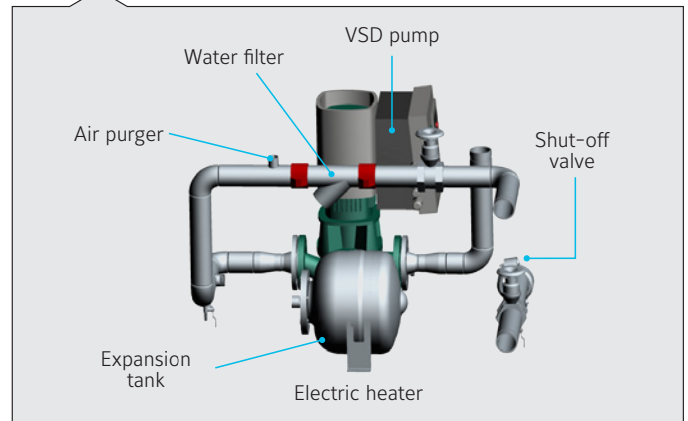

Easy installation

- Victaulic connections
- Water filter
- Flow switch
- Electrical heater on evaporator as standard

High performance and flexibility

The YORK® Amichi Series has up to 4 completely independent circuits to offer greater flexibility and performance.



YMPA 45 and 65
45kW and 65kW
2 compressors
1 circuit



YMPA 80 to 130
80kW, 100kW and 130kW
3-4 compressors
2 circuits



YMPA 160 and 200
160kW and 200kW
5-6 compressors
3 circuits



YMPA 230 and 260
230kW and 260kW
7-8 compressors
4 circuits

Amichi Series

Air cooled Scroll DC Inverter reversible heat pump

Main features



Always connected

- BACnet and Modbus communication protocol as standard.

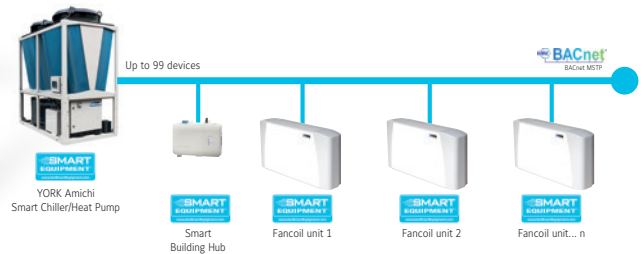

Easy to set up

Comfort, productivity and up to half of the energy used in your building – these are all factors affected by how your chiller operates and how it interacts with other components in your HVAC&R system.

To help maximize efficiency and keep you in control, the YORK® Amichi Series comes standard with integrated Smart Equipment. This technology allows the equipment to connect seamlessly to building controls where smart-enabled equipment can self-identify and interoperate. In addition, with the 7" Optiview LT touch panel, setting chiller parameters has never been easier.

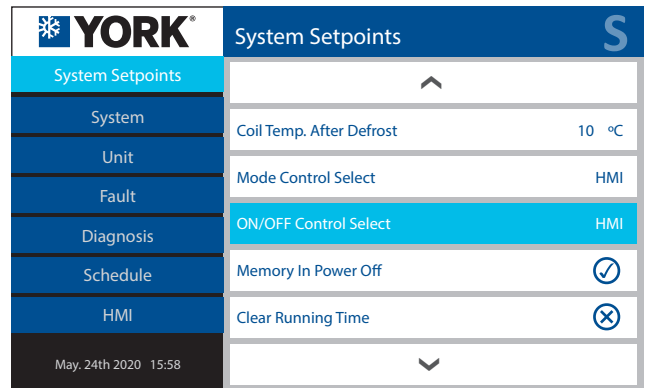

Maximum reliability

Every new YORK® chiller is subjected to a Highly Accelerated Life Test (HALT) during the design product development stages, allowing us to simulate a variety of extreme conditions and ensuring long-term operational reliability and quality. But our pursuit of quality doesn't stop there.

- **Intelligent defrost** optimizes the sequencing of the defrost cycle and allows the remaining modules in the system to continue to provide heat, reducing interruptions.
- **Compliance and certifications** include EcoDesign 2021 regulatory compliance, Eurovent certification and CE/PED certification.



Dimensions and hydraulic connections

YMPA 045 and 065 Single unit

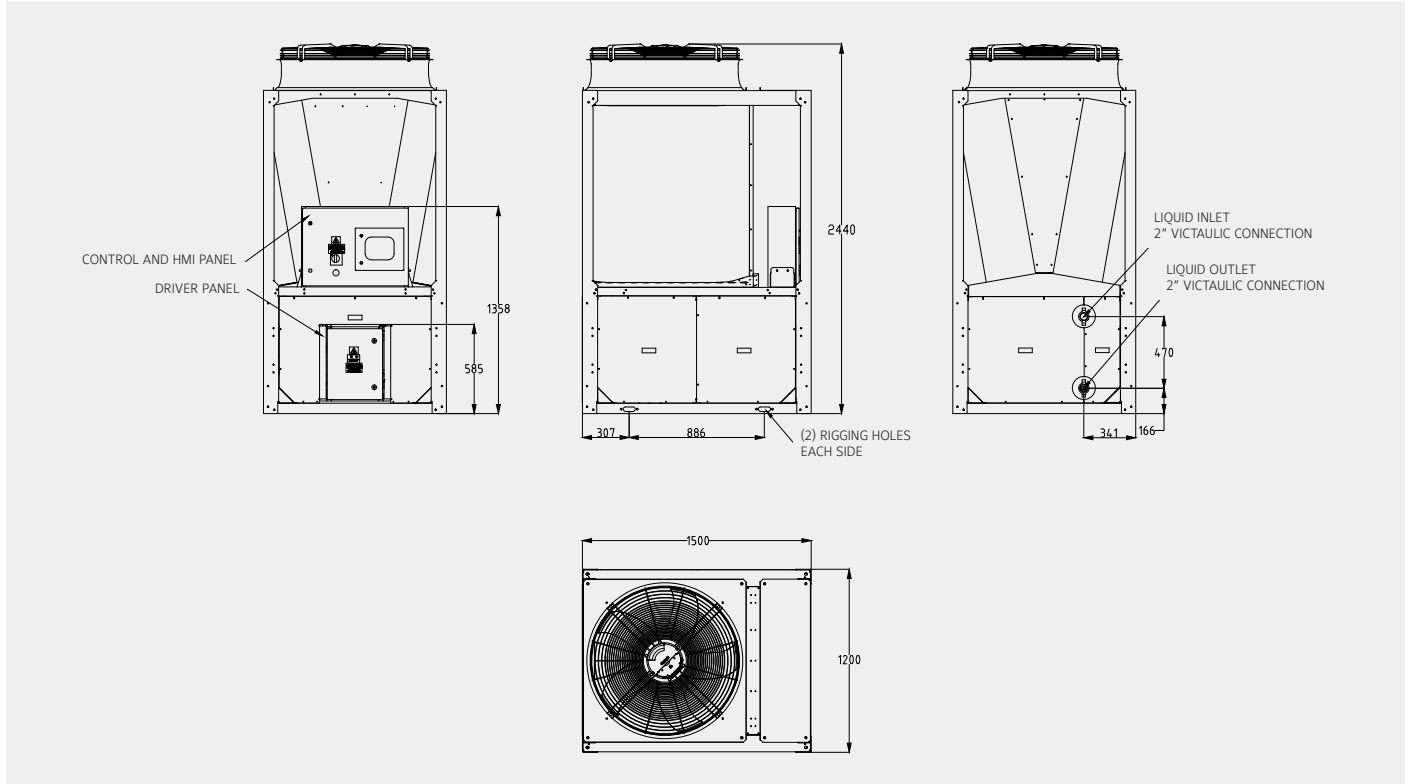

All dimensions in mm. Drawings not in scale.

YMPA 080 to 130 Single unit

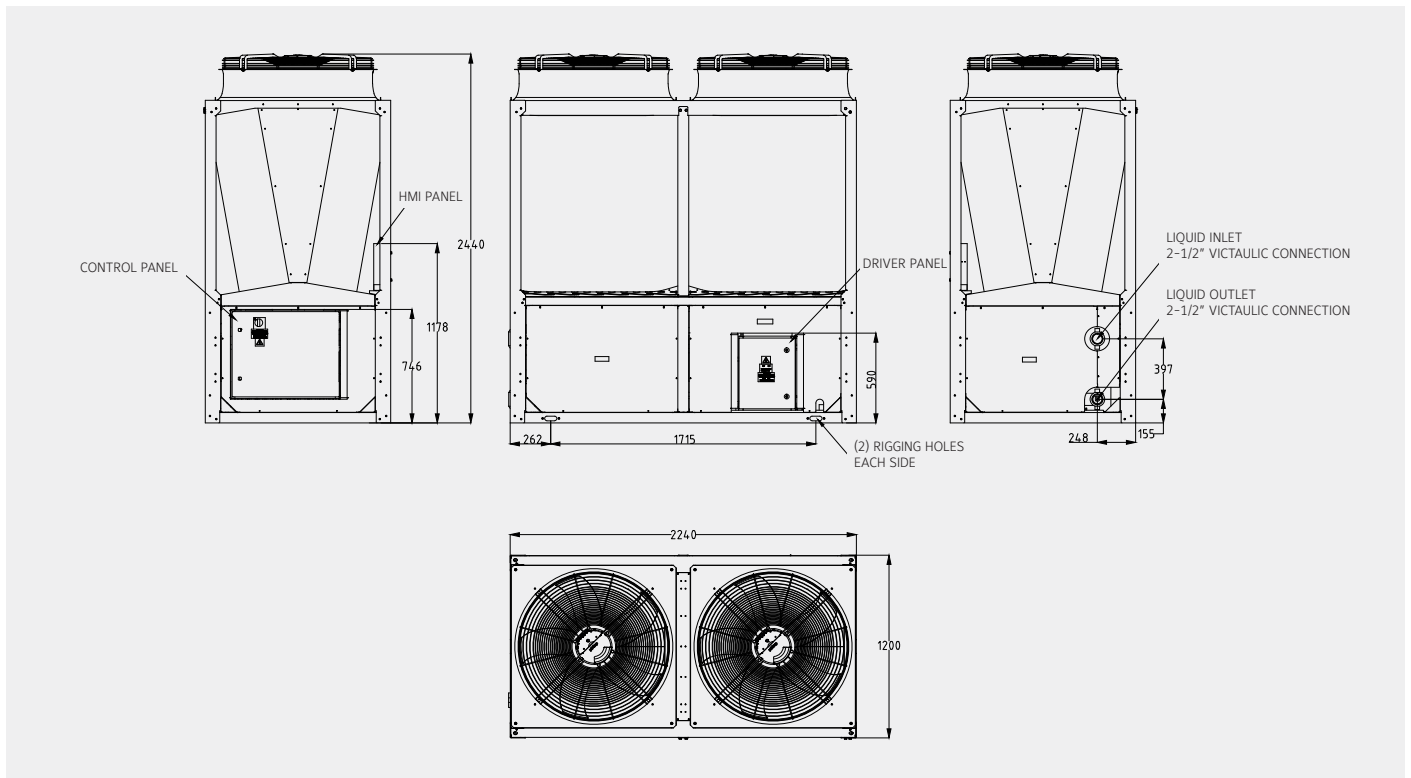

All dimensions in mm. Drawings not in scale.

YMPA 045 to 260



YMPA 160 and 200 Single unit

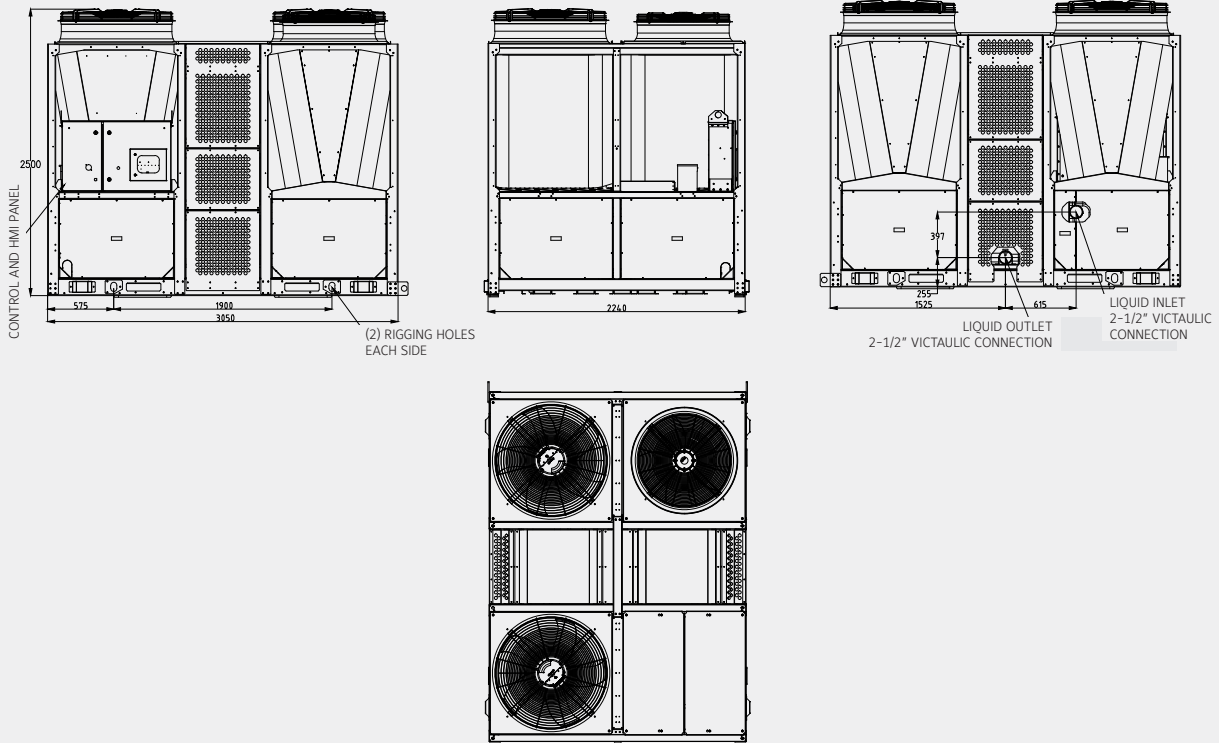

All dimensions in mm. Drawings not in scale.

YMPA 230 and 260 Single unit

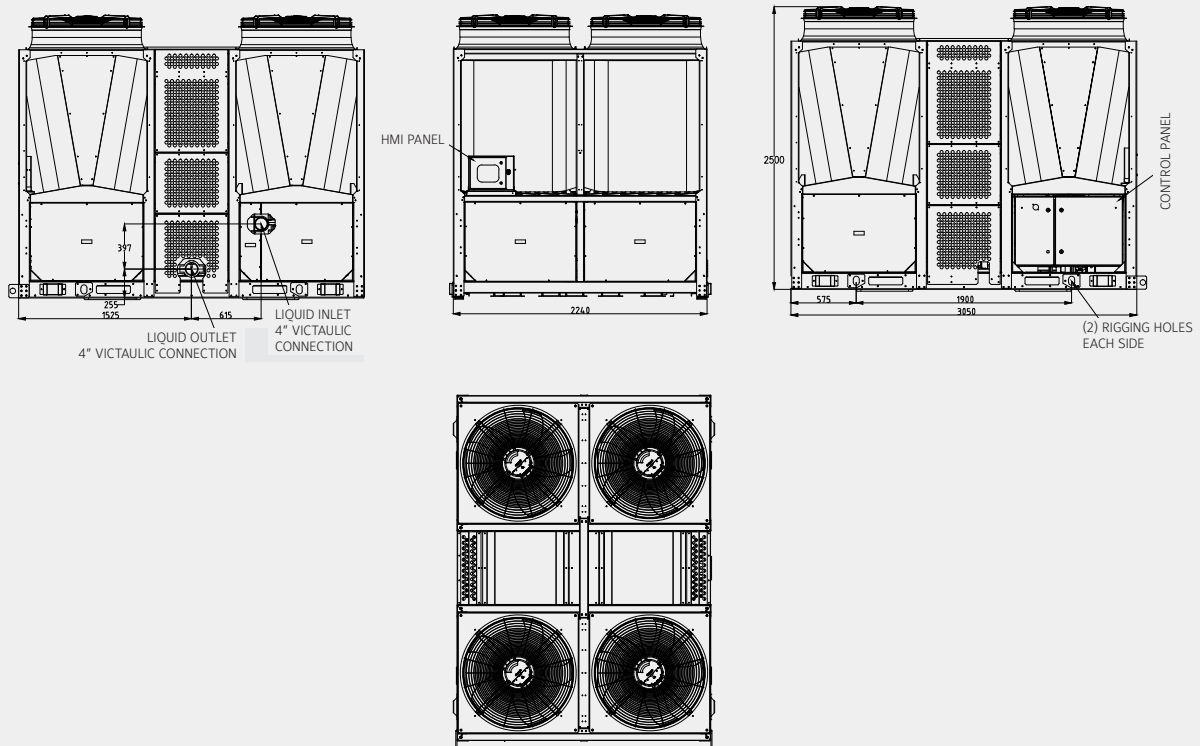

All dimensions in mm. Drawings not in scale.

YLPB

Heat pump scroll compressor

Cooling capacities from 336 kW to 628 kW

Heating capacities from 343 kW to 652 kW



Features

The **YLPB** heat pump delivers premium energy efficiency, it is easy to install, quiet to run, and it is supported by a knowledgeable service force.

Efficiency

One of the highest part load cooling efficiency unit in the market, improved defrost cycle, extended operating envelope. Maximize heating efficiency and renewable energy use with the **YLPB** heat pump.

Sound

Designed for quiet operation at full and part load conditions.

Ease of installation

Quick and easy to install, compact design. Smart Equipment and Verasys ready.

Reliability

The **YLPB** is our third generation of fully factory tested scroll heat pumps, and thanks to our extensive service solutions, support and minimal maintenance are assured.

Options/Accessories

- Soft start
- Power factor correction capacitors
- BMS interfacing options
- Dual pressure relief valves
- Victaulic coupling
- Flow switch
- Desuperheater
- Enclosure options
- Sound attenuation options
- Anti-vibration mounts options
- VSD single and dual pump kits



Multiple scroll design enables sound reduction during part load operation by simply turning off unnecessary compressors

Heat pump scroll compressor

YLPB 0345 to 0650



Nominal capacity

YLPB	0345	0430	0525	0575	0650
Cooling capacity (kW)	336	413	479	559	628
EER	2.98	2.93	2.88	2.94	2.98
SEER	4.36	4.55	4.47	4.53	4.51
$\eta_{s,c}$	171	179	176	178	177
Heating capacity (kW)	343	427	514	574	652
COP	3.06	3.07	3.03	2.99	3.01
SCOP	3.48	3.50	3.53	3.56	3.59
$\eta_{s,h}$	136	137	138	139	141
Sound Power Level (dBA)	94	94	95	96	97

Net values at Eurovent nominal conditions:

Cooling capacities in kW given for 7°C water leaving temperature Δt 5°C and 35°C ambient temperature.

Heating capacities in kW given for 45°C water leaving temperature and 7°C ambient temperature.

SCOP calculated according to EN14511 and EN14825.

η_s calculated according to Ecodesign regulation for heating (813/2013).

Ecodesign figures are calculated following fixed water and variable outlet approach (FW/VO). For other Ecodesign calculations, please contact your JCI representative.

The above data is based on Johnson Controls' selection software YORKworks 21.04a. Please refer to the latest version of the software for specific projects.

Technical data

YLPB			0345	0430	0525	0575	0650	
Dimensions	Length	mm	4721		5839		6958	
	Width	mm	2242					
	Height	mm	2391					
Operating weight		kg	3793	4043	4210	4747	5495	

High Efficiency Cooling Mode

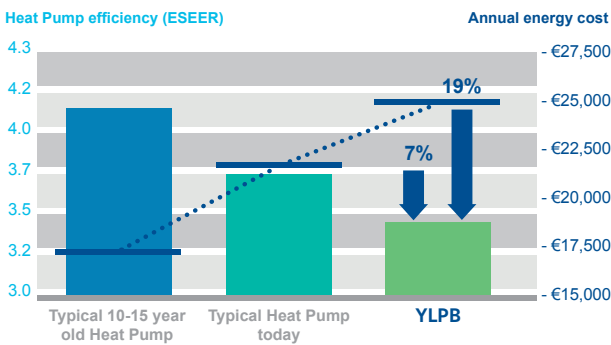

500 kW unit, 3000 operating hours, energy rate = 0.1 EUR / kWh

Additional Energy Savings in Heating Mode

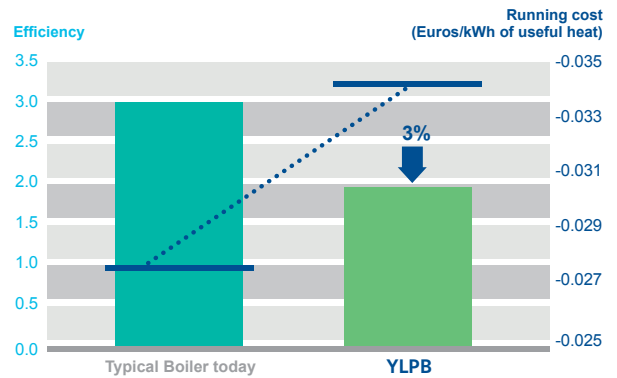

Energy Rate: Electricity 0.1 EUR / kWh; Gas 0.03 EUR / kWh

Operation limits

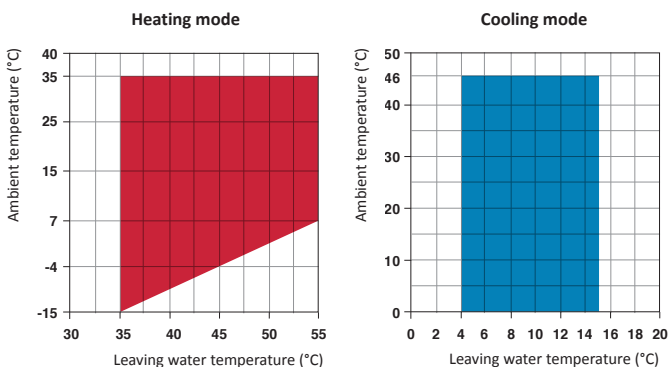

Carbon footprint in Heating Mode

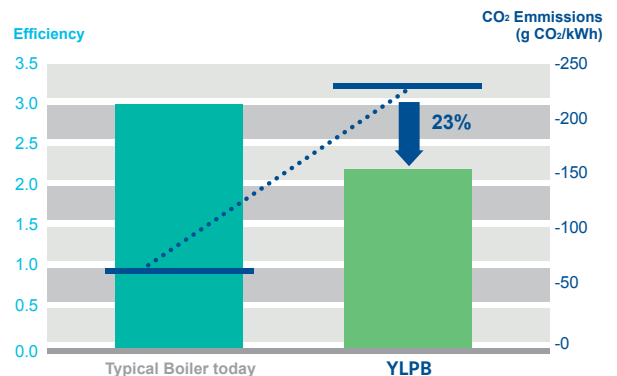

Manufacturer reserves the rights to change specifications without prior notice.

Dimensions and hydraulic connections

YLPB 0345 and 0430

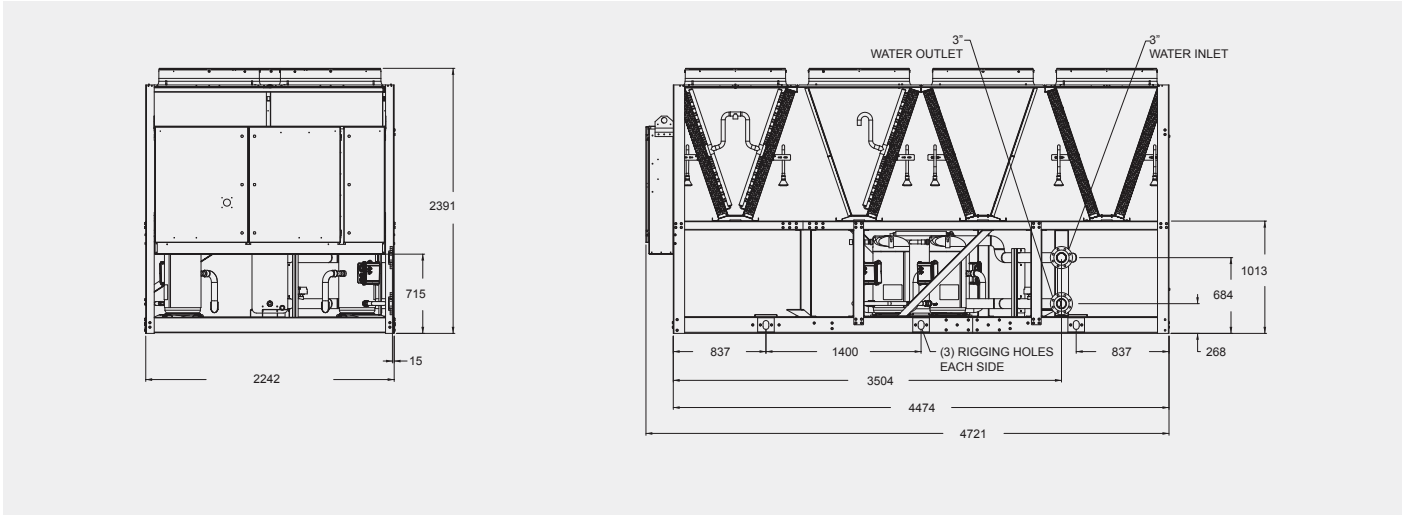

All dimensions in mm. Drawings not in scale.

YLPB 0525

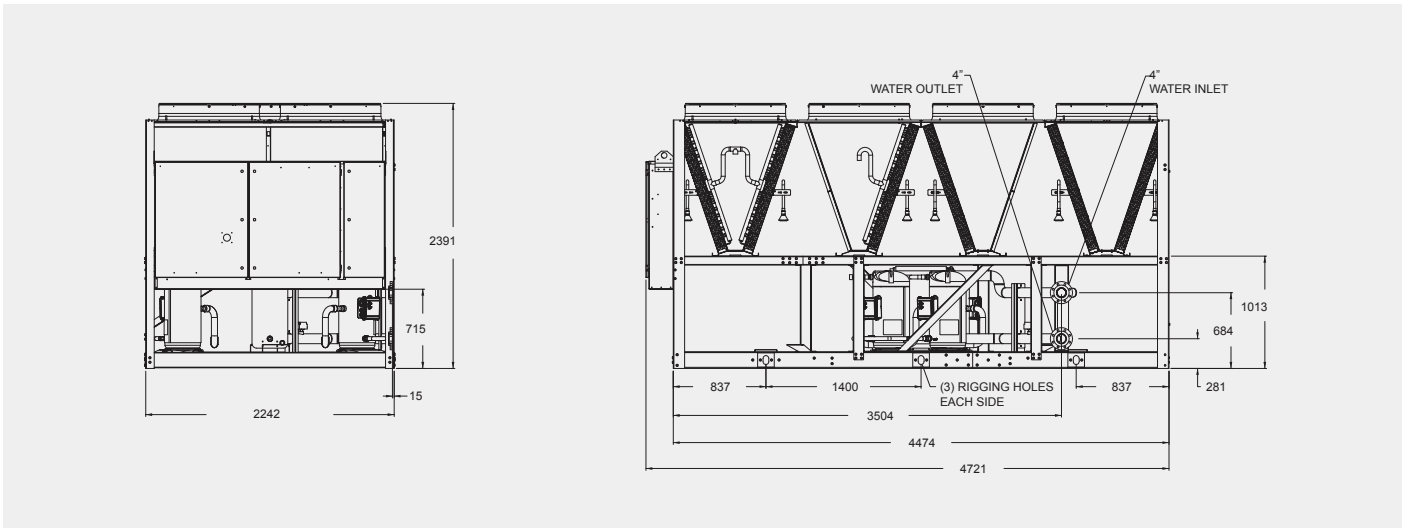

All dimensions in mm. Drawings not in scale.

YLPB 0345 to 0650



YLPB 0575

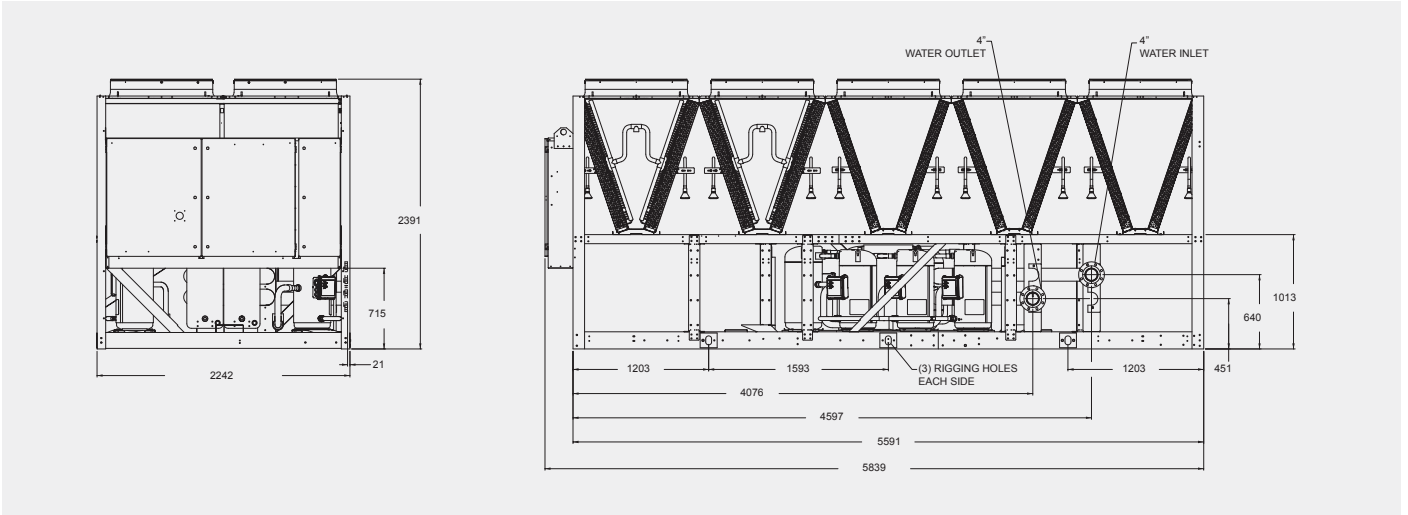

All dimensions in mm. Drawings not in scale.

YLPB 0650

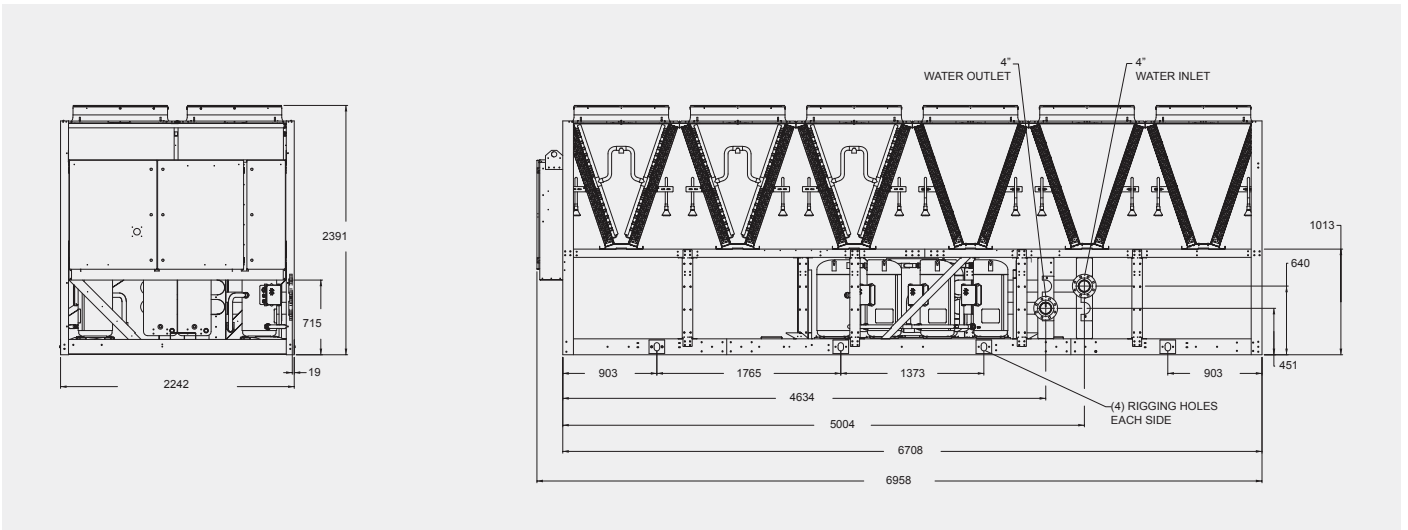

All dimensions in mm. Drawings not in scale.



YCPB Large Packaged Air-to-Water Scroll Heat Pump

Cooling capacities from 275 kW to 449 kW
Heating capacities from 305 kW to 507 kW



A new generation of Ecodesign compliant air-to-water heat pumps

Specifically designed as a low ambient heating solution, the new YCPB heat pump provides maximum heating with a wider operating range, thanks to the advanced large scroll compressors with Enhanced Vapor Injection (EVI) technology. In cold climates the YCPB has an improved heating capacity down to -25°C . In addition, the unit allows for production of hot water up to 60°C and cover more applications across an extended ambient range.

Its high-level heating SCOP leads the market without compromising the operation and efficiency of the cooling mode. This high performance is achieved through innovation, optimizing and combining only the best components, which translates into significant energy savings throughout the useful life of the heat pump.

The YCPB can be supplied as a 2-pipe system for typical reversible cooling and heating and will soon be available the 4-pipe version for simultaneous heating and cooling to meet full-year demand.



Advanced large scroll compressors with Enhanced Vapor Injection (EVI) & IDVs technologies

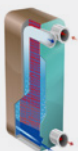

Heat exchangers specifically designed and optimized for high efficiency in heating and cooling modes



Super-efficient quiet fans with patented bionic design for low noise and high efficiency



Advanced 4-way reversing valve specifically designed for large capacity heat pumps



Large Packaged Air-to-Water Scroll Heat Pump

YCPB 0320 to 0520



Nominal capacity

YCPB Standard Efficiency			0320S	0420S	0520S
Cooling	Cooling Capacity	kW	274.7	364.2	448.7
	EER		2.89	2.97	2.99
	SEER		4.01	4.01	4.04
	$\eta_{s,c}$		157.5	157.3	158.6
Heating	Heating Capacity	kW	305.1	406	506.9
	COP		3.39	3.37	3.30
	SCOP		3.80	3.82	3.74
	$\eta_{s,h}$		149.1	149.9	146.6
Sound power level		dB(A)	91.5	92.0	92.5
Refrigerant	Type		R454B	R454B	R454B
	Circuit quantity	#	2	2	2
	Refrigerant charge circuit 1 / 2	kg	33.3 / 33.3	50.4 / 33.3	50.4 / 50.4
Compressor	Type		Scroll EVI system		
	Quantity	#	2 / 2	2 / 2	2 / 2
Air side heat exchanger	Fan quantity circuit 1 / 2		2 / 2	4 / 2	4 / 4
	Total air flow (standard fans)	m ³ /s	23.3	35.0	46.6
Water side heat exchanger	Type		Braze plate heat exchanger		
	Quantity	#	1	1	1
	Water volume	l	40	47	82
	Water connections	inches	4	4	4
Electrical features	Power supply		400V-3Ph-50Hz	400V-3Ph-50Hz	400V-3Ph-50Hz
Dimensions	Height	mm	2450	2450	2450
	Length	mm	3703	3703	4820
	Width	mm	2242	2242	2242
Weight	Shipping weight	kg	2608	3017	3681
	Operating weight	kg	2648	3064	3763

YCPB High Efficiency			0320H	0420H	0520H
Cooling	Cooling Capacity	kW	274.7	364.2	448.7
	EER		2.89	2.97	2.99
	SEER		4.22	4.26	4.21
	$\eta_{s,c}$		165.6	167.4	165.4
Heating	Heating Capacity	kW	305.1	406	506.9
	COP		3.39	3.37	3.30
	SCOP		4.09	4.16	4.04
	$\eta_{s,h}$		160.7	163.2	158.5
Sound power level		dB(A)	91.5	92.0	92.5
Refrigerant	Type		R454B	R454B	R454B
	Circuit quantity	#	2	2	2
	Refrigerant charge circuit 1 / 2	kg	33.3 / 33.3	50.4 / 33.3	50.4 / 50.4
Compressor	Type		Scroll EVI system		
	Quantity	#	2 / 2	2 / 2	2 / 2
Air side heat exchanger	Fan quantity circuit 1 / 2		2 / 2	4 / 2	4 / 4
	Total air flow (standard fans)	m ³ /s	23.3	35.0	46.6
Water side heat exchanger	Type		Braze plate heat exchanger		
	Quantity	#	1	1	1
	Water volume	l	40	47	82
	Water connections	inches	4	4	4
Electrical features	Power supply		400V-3Ph-50Hz	400V-3Ph-50Hz	400V-3Ph-50Hz
Dimensions	Height	mm	2450	2450	2450
	Length	mm	3703	3703	4820
	Width	mm	2242	2242	2242
Weight	Shipping weight	kg	2672	3084	3751
	Operating weight	kg	2712	3131	3833

1. Net values at Eurovent nominal conditions:

- Cooling capacities in kW given for 7°C leaving water temperature, 12°C entering water temperature and 35°C ambient temperature.
- Heating capacities in kW given for 45°C leaving water temperature, 40°C entering water temperature and 7°C ambient temperature.
- SEER and SCOP are calculated according to EN14511 and EN14825.
- η_{s} is calculated according to Ecodesign regulation for chillers comfort cooling and heating (813/2013, 2016/2281)

2. Ecodesign figures are calculated following variable water and variable outlet approach (VW/VO). For other Ecodesign calculations, please contact your JCI representative

3. The sound power levels shown refer to models with acoustic blanket option and following the ISO9614 standard.



Manufacturer reserves the rights to change specifications without prior notice.

Innovative technology

The YORK® YCPB uses an array of advanced technologies to deliver higher temperature, optimized efficiency and reliable operation.

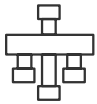

4-way reversing valve

Specifically designed for large capacity heat pumps. This valve brings an extremely low refrigerant pressure drop thanks to a unique dual liquid channels design.



Filter dryer

Perfect protection of the system by removing contaminants and moisture from the refrigerant.



High-efficiency economizer

High-efficiency economizer boosts capacity, improves system efficiency and reduces operating costs.



Suction accumulator and R454B low GWP refrigerant

Optimized for R454B with less refrigerant charging.





Super-efficient quiet fans

New Johnson Controls patented bionic design for low noise and high efficiency. Greatly improves unit efficiency and reduces noise level at all configurations, maintaining optimum head pressure.



Cu tube & Al fin ambient coil

Specifically designed for heat pumps and optimized for high efficiency in heating and cooling mode. Hydrophilic coating as standard to shed water during defrost, provide corrosion resistance, improve airflow and overall optimize heat exchange efficiency.



Electronic expansion valve

Precise positioning for optimal control of refrigerant.



Intelligent control

Leveraging technology and expertise from YORK and Johnson Controls, the YCPB is equipped with our own uniquely powerful microprocess controller and easy-to-use HMI.



VSD fan (optional)

Increased efficiency and sound performance at partial load.



Large EVI scroll compressors Tandem/Trio design

Dual circuits with Tandem/Trio configuration advanced large scroll compressors with EVI & IDVs technologies for high temperature applications and low ambient operations.

High performance

2-Pipe & 4-Pipe (coming soon) applications

- 2-Pipe for typical reversible cooling and heating.
- 4-Pipe (coming soon) designed for year-round simultaneous heating and cooling, ensuring both hot and chilled water are available on demand.

Ideal applications:

- Comfort cooling and heating for shopping centers, hospitals, hotels, office buildings, schools, etc.
- Process cooling and heating

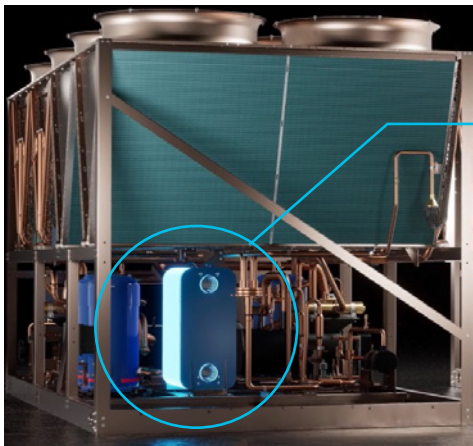

2-Pipe

4-Pipe
(coming soon)

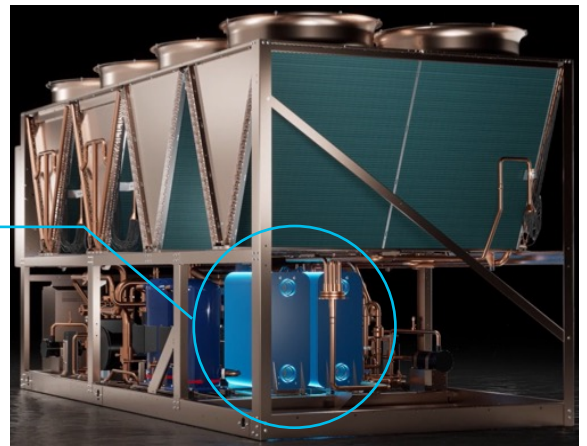

Advanced large scroll compressor with EVI & IDVs

- Dedicated heat pump for high temperature or low ambient operations.
- New large Scroll integrated with Enhanced Vapor Injection (EVI) & IDVs technologies.
- Extended envelop ensures heating capacity and efficiency at low ambient.
- Dual circuits with Tandem/Trio compressors, well balance full load and part load at all configurations.
- Optimized for R454B.

Enhanced Vapor Injection (EVI)

- Optimized refrigeration cycle with economizer

Intermediate Discharge Valves (IDVs)

- Improved compressor efficiency at part load.



High efficiency heat exchangers

Specifically designed for heat pumps and optimized for high efficiency in heating and cooling mode.

Refrigerant-to-water heat exchanger

- Unique features to boost unit performance:
 - Flexible refrigerant distribution system
 - Superior thermal performance
 - Controlled, non-destructive freezing
 - Unparalleled strength for high demands
- Heating counterflow design to remarkably improve heating efficiency.
- Optimized for R454B with less refrigerant charge.
- A weight savings of 10-15% - less structural steel required in the building, lower crane costs.
- Proven reliability.

Dimensions and hydraulic connections

YCPB0320 SE with fixed-speed fan (2-pipe)

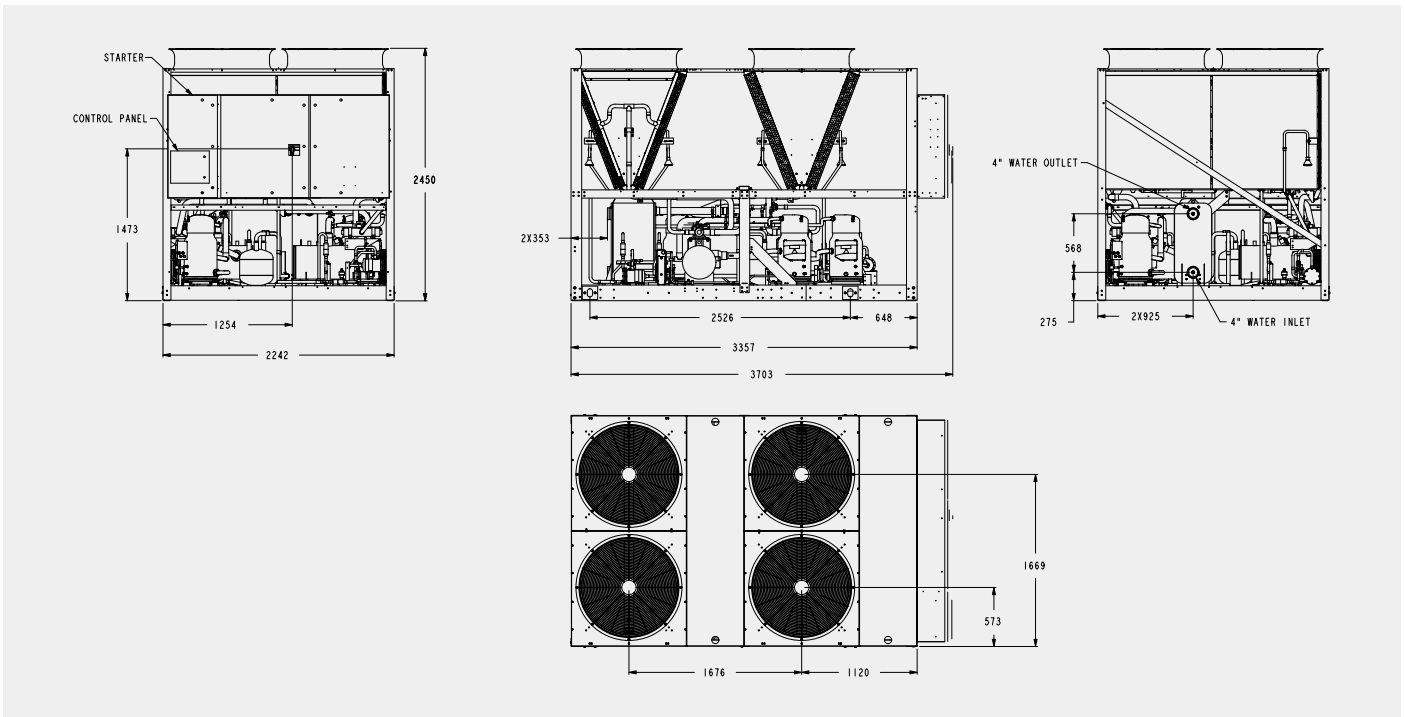

YCPB0320 HE with VSD fan (2-pipe)

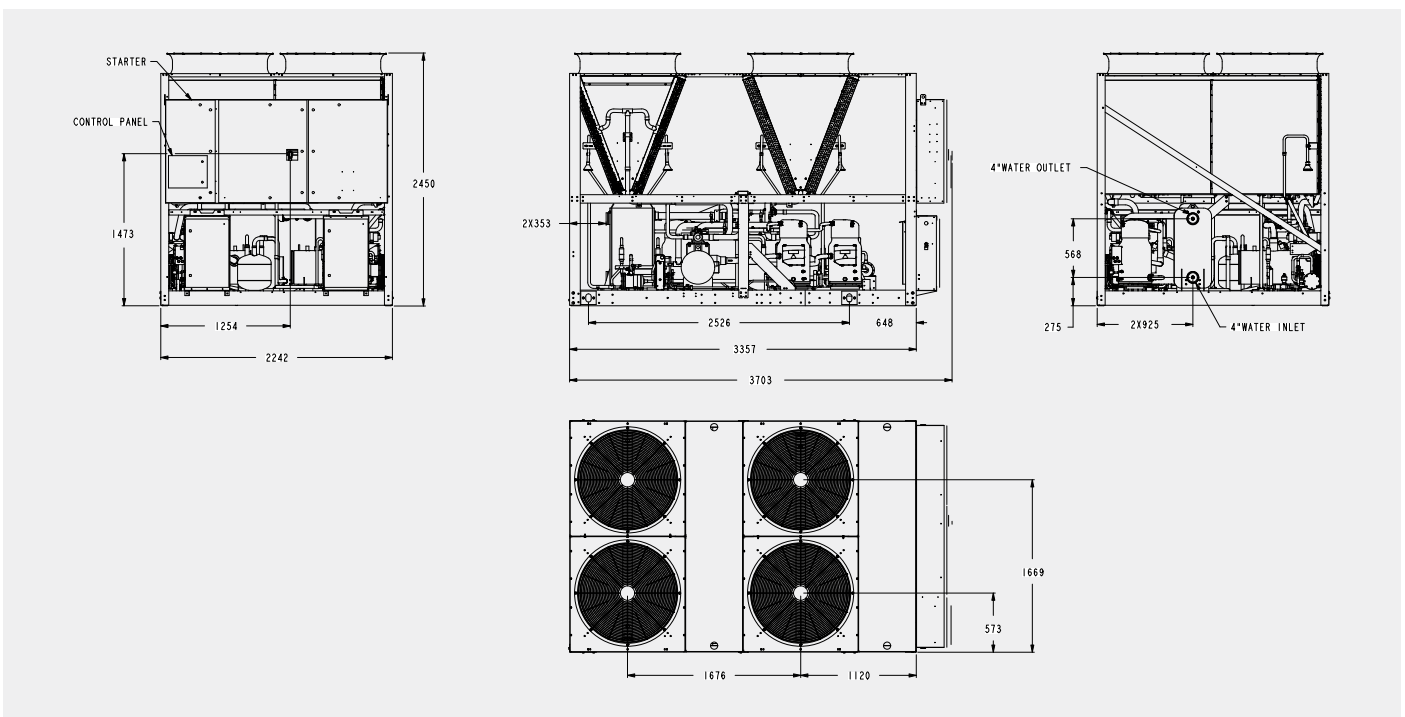

Dimensions and hydraulic connections

YCPB0420 SE with fixed-speed fan (2-pipe)

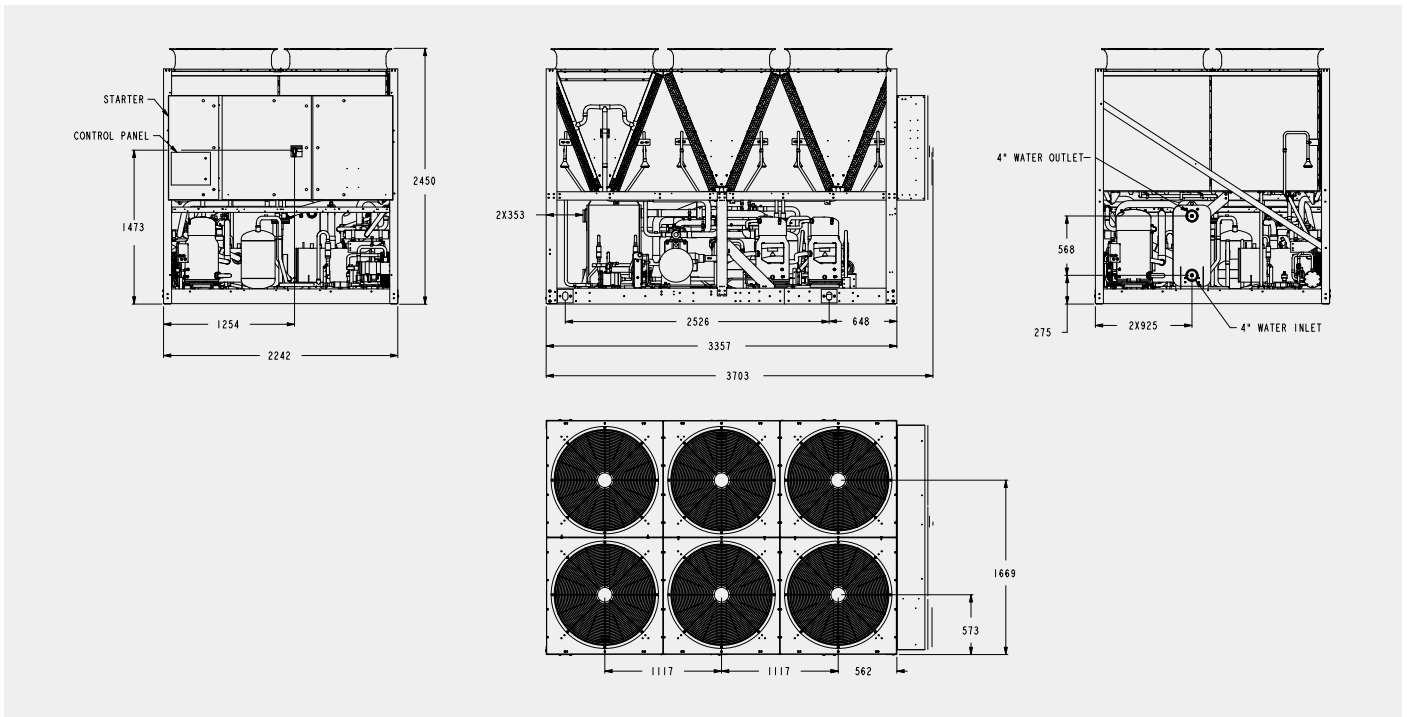

YCPB0420 HE with VSD fan (2-pipe)

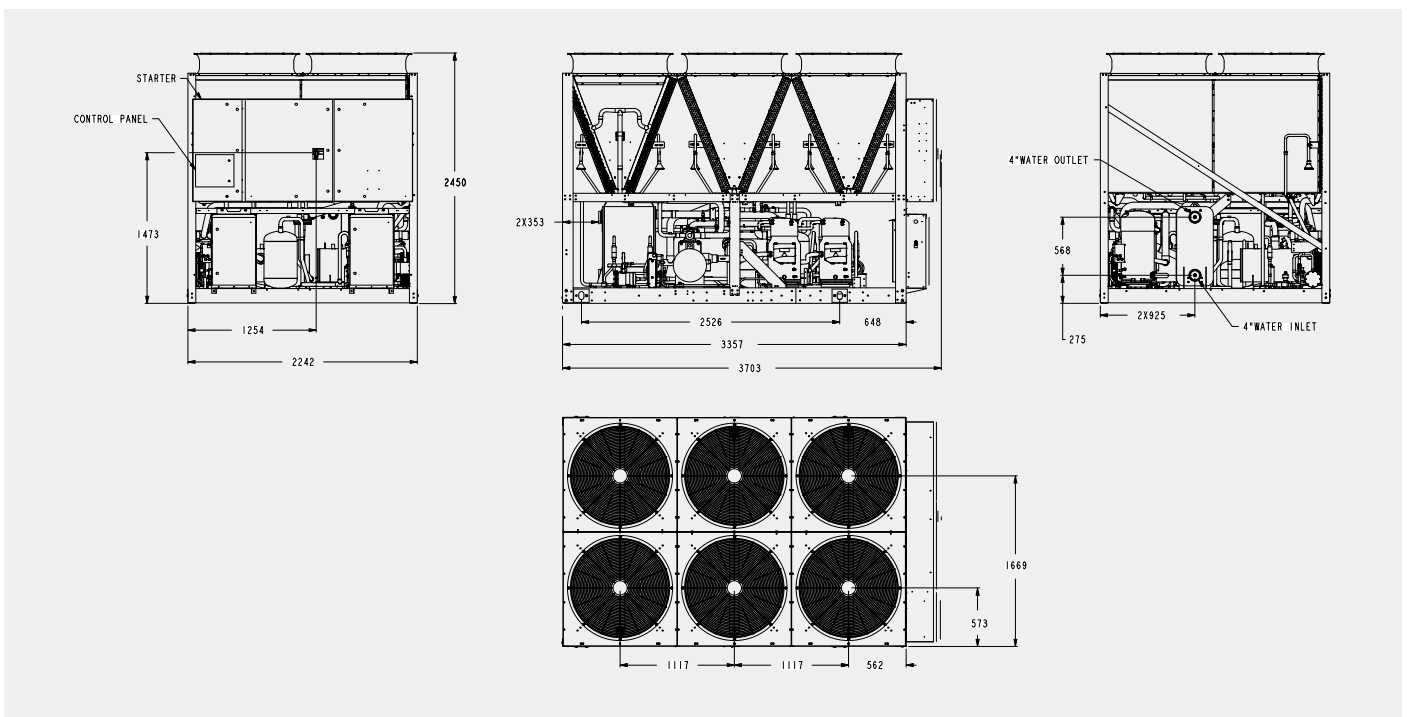

Dimensions and hydraulic connections

YCPB0520 SE with fixed-speed fan (2-pipe)

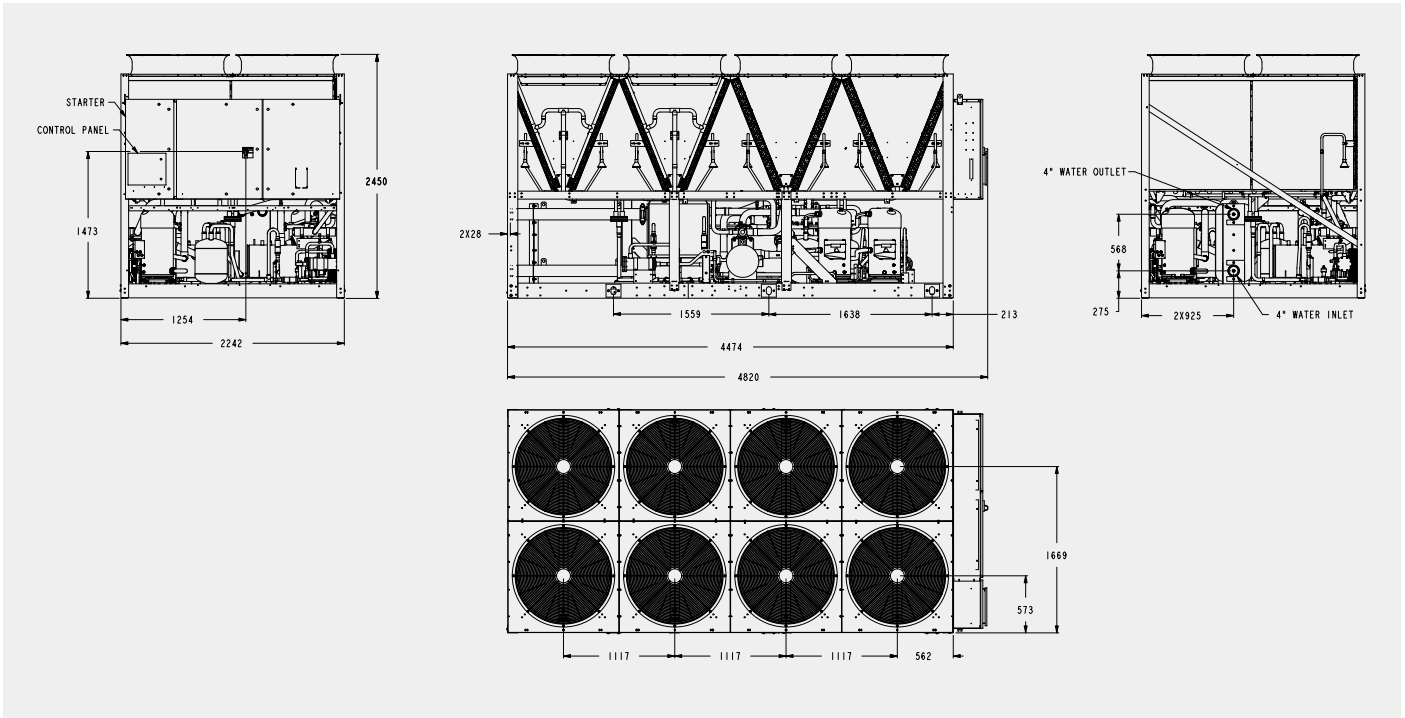

YCPB0520 HE with VSD fan (2-pipe)

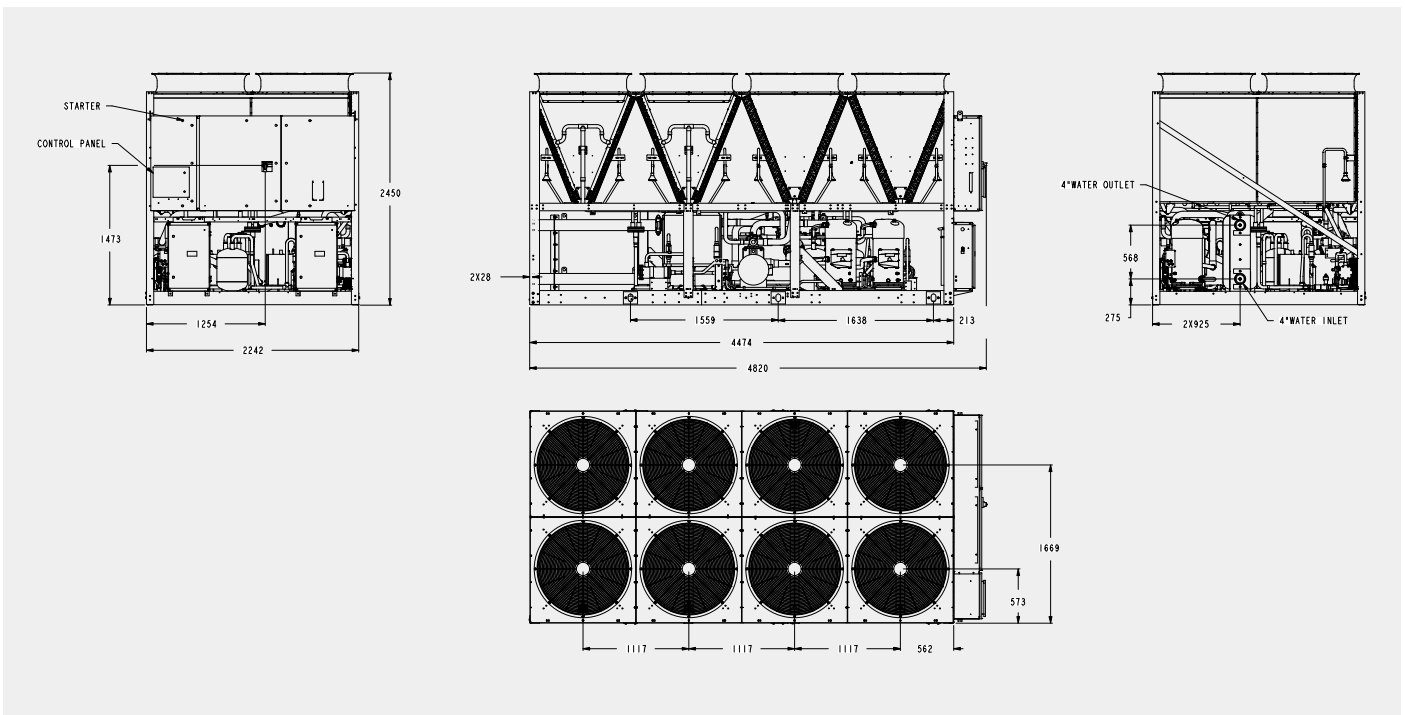

YTH Air to Water Reversible Heat Pump with Scroll compressors

Cooling capacities from 16.8 kW to 76 kW
Heating capacities from 17.8 kW to 67.6 kW



Top class energy efficiency high temperature air-cooled reversible heat pumps, ideal for heating, cooling and domestic hot water production

Single-block aircooled reversible heat pumps, for heating and cooling of environments and the production of domestic hot water, by means of technical water accumulation. YTH units are ideal for new buildings or replacement of existing systems with low energy consumption, also in combination with an existing boiler. YTH offers a simple and reliable comfort management solution for all seasons, with the utmost attention to energy savings.

The heat pumps of the YTH range use the new ecological refrigerant R454C, with low global warming potential (GWP=146), in line with European Directive F-gas for the progressive reduction of the use of greenhouse gases.

YTH 2-Pipe Scroll Units

- High part-load energy efficiency with excellent SCOP values
- DHW production and hybrid system management
- Wide operating range, working at **-20°C** outdoor temperature
- Hot water up to **65°C**
- Silent operation thanks to SL option
- Quick Plug & Play installation with built-in hydraulic options
- **R454C** low GWP refrigerant

Working configurations:

		Cooling + Domestic Hot Water production
		Heating + Domestic Hot Water production
		Domestic Hot Water production

Efficient all year round!

Hot water up to 65°C with high performance and excellent energy efficiency levels. Heating operation with hot water production starting from an outdoor air temperature of -20°C during winter and up to +40°C in the summer.

Air to Water Reversible Heat Pump with Scroll compressors

YTH 0020 to 0070



Technical features (R454C)

Model			YTH-0020-SRF-HP	YTH-0025-SRF-HP	YTH-0030-SRF-HP
Cooling (EN14511)	Cooling Capacity ¹	kW	16.80	18.80	24.40
	EER ¹		3.20	3.10	3.14
	Cooling Capacity ²	kW	22.70	25.80	33.20
	EER ²		3.85	3.85	3.81
Heating (EN14511)	Heating Capacity ³	kW	19.10	21.90	27.40
	COP ³		3.38	3.40	3.35
	Heating Capacity ⁴	kW	20.50	23.40	29.10
	COP ⁴		4.20	4.24	4.14
	Heating Capacity ⁵	kW	17.80	20.60	25.60
	COP ⁵		2.71	2.71	2.70
	SCOP ⁶		3.59	3.89	3.90
	Energy efficiency ⁶	%	141	153	153
	Energy Class ⁷		A+	A++	A++
	SCOP ⁸		2.91	3.14	3.15
	Energy efficiency ⁸	%	113	123	123
	Energy Class ⁹		A+	A+	A+
Compressors	Quantity	#	2	2	2
	Refrigerant circuits	#	1	1	1
Electrical characteristics	Power supply	V/Ph/Hz	400/3+N/50		
	Height	mm	1300	1300	1300
Dimensions	Length	mm	1850	1850	1850
	Width	mm	1000	1000	1000

Model			YTH-0035-SRF-HP	YTH-0045-SRF-HP	YTH-0055-SRF-HP	YTH-0070-SRF-HP
Cooling (EN14511)	Cooling Capacity ¹	kW	29.50	37.20	47.50	56.10
	EER ¹		3.18	3.04	2.98	3.05
	Cooling Capacity ²	kW	40.00	50.80	63.80	76.00
	EER ²		3.81	3.73	3.52	3.63
Heating (EN14511)	Heating Capacity ³	kW	31.90	42.40	51.70	63.50
	COP ³		3.32	3.13	3.18	3.16
	Heating Capacity ⁴	kW	33.90	45.40	55.20	67.60
	COP ⁴		4.13	3.90	3.93	3.94
	Heating Capacity ⁵	kW	29.90	39.70	48.40	59.60
	COP ⁵		2.67	2.50	2.56	2.54
	SCOP ⁶		3.70	3.35	3.38	3.51
	Energy efficiency ⁶	%	145	131	132	137
	Energy Class ⁷		A+	A+	A+	A+
	SCOP ⁸		2.96	2.82	2.83	2.90
	Energy efficiency ⁸	%	115	110	110	113
	Energy Class ⁹		A+	A+	A+	A+
Compressors	Quantity	#	2	4	4	4
	Refrigerant circuits	#	1	2	2	2
Electrical characteristics	Power supply	V/Ph/Hz	400/3+N/50			
	Height	mm	1920	2220	2220	2220
Dimensions	Length	mm	2350	2850	2850	2850
	Width	mm	1100	1100	1100	1100

1. Chilled water from 12 to 7 °C, ambient air temperature 35 °C.
2. Chilled water from 23 to 18 °C, ambient air temperature 35 °C.
3. Heated water from 40 to 45 °C, ambient air temperature 7 °C d.b./6 °C w.b.
4. Heated water from 30 to 35 °C, ambient air temperature 7 °C d.b./6 °C w.b.
5. Heated water from 47 to 55 °C, ambient air temperature 7 °C d.b./6 °C w.b.
6. Seasonal energy efficiency of heating at low temperature with average climatic conditions according to EU Regulation no. 813/2013.
7. Seasonal energy efficiency class of heating at low temperature with average climatic conditions according to EU Regulation no. 811/2013.
8. Seasonal energy efficiency of ambient heating at medium temperature with average climatic conditions. According to EU Regulation n. 813/2013.
9. Seasonal energy efficiency class of heating at medium temperature with average climatic conditions according to EU Regulation no. 811/2013.

The above table only shows net (EN14511) performance values of YTH units operating with R454C refrigerant.
For more information, please contact your Johnson Controls representative.



Manufacturer reserves the rights to change specifications without prior notice.



YTL

Air to Water Reversible Heat Pump with Scroll compressors

Cooling capacities from 186 kW to 653 kW
Heating capacities from 202 kW to 712 kW



Features

- Low GWP Refrigerant: R454B
- Reversible heat pump (4 way valve)
- On-off compressor
- EC inverter fans
- Plate heat exchangers
- Hot water up to 55°C
- Heat recovery
- A Class Efficiency: SEER up to 4.59
- Full Control with Web Monitoring (option)
- Different Noise Levels: Standard - Silent - Super Silent

Multi-Scroll Compressor Technology

Double cooling circuit with up to 6+6 compressors: efficiency at part load

- DOUBLE COOLING CIRCUIT on all models.
- MULTI-COMPRESSOR design depending on capacity: 2+2 / 3+3 / 4+4 / 5+5 / 6+6.
- High SEER/SCOP: **Efficiency at part load**

Multi-compressor design

- **Compressors activated by STEPS:** delivered power by steps; absorbed power by steps.
- Minimum number of compressors activated: 1 or 2, depending on model
- Soft start: unit can start with only 1 or 2 compressors
- No inertial storage tank: high number of capacity steps

Air to Water Reversible Heat Pump with Scroll compressors

YTL 0215 to 0755



Technical features (R454B)

YTL_SRL-HP model		0215	0240	0265	0295	0325	0360	0390	0430	0475	0525	0590	0665	0755	
Cooling Capacity ¹	kW	185.8	207.6	231.2	255.7	283.1	310.5	340.7	373.7	410.6	457.8	507.9	575	653.3	
Absorbed power ¹	kW	59.5	66.1	72.7	79.4	90.9	100.4	106.1	118.4	130.8	147	161.3	183.3	209.9	
EER ¹		3.08	3.1	3.14	3.18	3.07	3.06	3.17	3.12	3.1	3.09	3.12	3.11	3.09	
SEER ²	kW	4.14	4.15	4.19	4.2	4.16	4.16	4.17	4.44	4.51	4.54	4.52	4.51	4.55	
Energy Efficiency ²	%	163	163	165	165	163	163	164	175	177	179	178	177	179	
Heating Capacity ³	kW	202.3	226	251.5	278.9	307.2	339.2	369.5	407.4	447.1	497	553.7	626.4	712.3	
Absorbed power ³	kW	62.9	70.6	78.3	84.9	95.7	105.4	114.9	124.5	138	156.3	169.8	195	222.8	
COP ³		3.17	3.15	3.17	3.24	3.16	3.18	3.17	3.22	3.19	3.15	3.22	3.18	3.17	
SCOP ⁴	kW	3.32	3.39	3.32	3.31	3.34	3.31	3.32	3.33	3.29	3.33	3.28	3.3	3.4	
Energy Efficiency ⁴	%	130	133	130	129	131	129	130	130	129	130	128	129	133	
Airflow (SL version)	m ³ /h	29.3	29.3	29.3	29.3	38.8	38.8	38.8	38.8	38.8	48.8	48.8	58.3	58.3	
Fans quantity	#	6	6	6	6	8	8	8	8	8	10	10	12	12	
Sound power	dB(A)	91.1	92	93.2	93.8	93.8	94.1	94.1	95.4	95.7	95.8	96.9	97.7	98.2	
Sound power (SL version)	dB(A)	88.1	89	90.2	90.8	90.8	91.1	92.1	92.4	92.7	92.8	93.9	94.7	95.2	
Sound pressure	dB(A)	71.6	72.5	73.7	74.3	73.9	74.2	74.2	75.5	75.8	75.3	76.4	76.8	77.3	
Sound pressure (SL)	dB(A)	68.6	69.5	70.7	71.3	70.9	71.2	72.2	72.5	72.8	72.3	73.4	73.8	74.3	
Quantity compressors	#	3+3	3+3	3+3	3+3	4+4	4+4	4+4	5+5	5+5	6+6	6+6	6+6	6+6	
Refrigerant circuits	#	2	2	2	2	2	2	2	2	2	2	2	2	2	
Capacity steps		6	6	6	6	8	8	8	8	8	10	10	10	10	
Power supply	V/Ph/Hz	400/3+N/50													
Dimensions	Height	mm	4000	4000	4000	4000	5000	5000	5000	5000	5000	6200	6200	7200	7200
	Length	mm	2200	2200	2200	2200	2200	2200	2200	2200	2200	2200	2200	2200	2200
	Width	mm	2100	2100	2100	2100	2100	2100	2100	2100	2100	2100	2100	2100	2100

1. Chilled water from 12 to 7 °C, ambient air temperature 35 °C.
2. Seasonal energy efficiency of cooling at low temperature with average climatic conditions according to EU Regulation no. 2016/2281.
3. Heated water from 40 to 45 °C, ambient air temperature 7 °C d.b./6 °C w.b.
4. Seasonal energy efficiency of heating at low temperature with average climatic conditions according to EU Regulation no. 813/2013.

The above table only shows net (EN14511) performance values of YTL units operating with R454B refrigerant. For more information, please contact your Johnson Controls representative.



Manufacturer reserves the rights to change specifications without prior notice.



YTL Air to Water Reversible Heat Pump with Screw compressors

Cooling capacities from 257 kW to 1109 kW
Heating capacities from 266 kW to 1151 kW



YTL Screw Units

- Low GWP Refrigerant: R513A (also R134a available as option)
- Reversible heat pump (4 way valve)
- Stepless or Inverter compressor
- EC inverter fans
- Shell and Tube Heat Exchangers
- Hot water up to 55°C
- Heat recovery
- A Class Efficiency: SEER up to 4.86
- Full Control with Web Monitoring (option)
- Different Noise Levels: Standard - Silent - Super Silent

Inverter Control (option) Screw Compressor

Continuous modulation of delivered and absorbed power

Designed for high temperature applications: high power and efficiency

- High efficiency screw Rotor profile - hyper volumetric efficiency.
- High efficiency motor.
- Capacity control with Inverter regulation.
- ECONOMIZER.
- Low friction components: high reliability and efficiency.
- High performance INTEGRAL OIL SEPARATOR.

The screw compressor is managed by an **Inverter Variable Frequency Drive** that electronically modulates the compressor speed according to the required cooling load.

- Delivered & absorbed power is PROPORTIONALLY modulated on the compressor with Inverter.
- No step regulation.
- Minimized absorbed power when working at part load.

Air to Water Reversible Heat Pump with Screw compressors

YTL 0270 to 1180



Technical features (R513A)

YTL_SCJ-HP model		0270	0325	0370	0430	0480	0595	0720	0870	0995	1180	
Cooling Capacity ¹	kW	256.6	305.5	350.3	403.1	452.9	560.5	679.6	819.4	936.5	1109.4	
Absorbed power ¹	kW	82.6	96.4	115.1	131.8	146.5	179	219.3	256.5	305.6	352.9	
EER ¹		3.11	3.17	3.04	3.06	3.09	3.13	3.1	3.19	3.06	3.14	
SEER ²	kW	4.09	4.21	4.18	4.28	4.33	4.37	4.26	4.41	4.46	4.37	
Energy Efficiency ²	%	161	165	164	168	170	172	167	173	175	172	
Heating Capacity ³	kW	266.4	317.1	364.3	419.2	470	581.3	705.8	850.8	971.8	1150.9	
Absorbed power ³	kW	79.2	91.9	110	126.1	139.2	172.1	212.6	249.3	294.8	340.3	
COP ³		3.36	3.45	3.31	3.32	3.38	3.38	3.32	3.41	3.3	3.38	
SCOP ⁴	kW	3.2	3.29	3.31	3.3	3.29	3.31	3.29	3.33	3.29	3.33	
Energy Efficiency ⁴	%	125	129	129	129	129	129	129	130	129	130	
Airflow (SL version)	m ³ /h	29.3	29.3	29.3	38.9	38.9	48.7	58.3	77.7	77.7	82.2	
Fans quantity	#	6	6	6	8	8	10	12	16	16	16	
Sound power	dB(A)	95.8	95.5	96.2	96.4	97.4	96.8	98.2	99.2	99	100.2	
Sound power (SL version)	dB(A)	92.5	92.6	93.2	93.2	94.4	93.8	95.2	96.2	96	97.2	
Sound pressure	dB(A)	76.1	75.8	76.3	76.2	76.9	76.1	76.8	77.1	76.9	77.7	
Sound pressure (SL)	dB(A)	72.8	72.9	73.3	73	73.9	73.1	73.8	74.1	73.9	74.7	
Quantity compressors	#	2	2	2	2	2	2	2	2	2	2	
Refrigerant circuits	#	2	2	2	2	2	2	2	2	2	2	
Capacity steps		Stepless										
Power supply	V/Ph/Hz	400/3+N/50										
Dimensions	Height	mm	2100	2100	2100	2100	2100	2100	2100	2100	2100	2500
	Length CO	mm	4400	4400	5000	5550	6200	6700	8900	11100	11100	11100
	Length HP	mm	5550	5550	5550	7750	7750	8900	10050	13400	13400	13400
	Width	mm	2200	2200	2200	2200	2200	2200	2200	2200	2200	2200

1. Chilled water from 12 to 7 °C, ambient air temperature 35 °C.

2. Seasonal energy efficiency of cooling at low temperature with average climatic conditions according to EU Regulation no. 2016/2281.

3. Heated water from 40 to 45 °C, ambient air temperature 7 °C d.b./6 °C w.b.

4. Seasonal energy efficiency of heating at low temperature with average climatic conditions according to EU Regulation no. 813/2013.

The above table only shows net (EN14511) performance values of YTL units operating with R513A refrigerant although they are also available with R134a. For more information, please contact your Johnson Controls representative.



Manufacturer reserves the rights to change specifications without prior notice.

YCH

4-Pipe Multifunctional units with Scroll compressors and plate exchangers

Cooling capacities from 46.5 kW to 518.9 kW
 Heating capacities from 50.1 kW to 563.5 kW



Multifunctional Operation

Simultaneous production of cooling, heating and domestic hot water

On complex buildings where there is simultaneous need of cooling and heating, YCH is capable to provide them at the same time with the maximum efficiency in every season of the year.

YCH allows to combine the three contemporary functioning modes – cooling, heating and domestic hot water production – to reach several working configurations.

Besides the standard components of a traditional chiller, the units are equipped with three exchangers (plate heat exchanger on cooling side, plate heat exchanger on heating side and finned coil exchanger on the disposable side) and a refrigerant circuit, which configuration varies depending on the type of request of the system. This is made possible by a series of solenoid valves, controlled by a microprocessor, which diverts the refrigerant flow in the exchanger suitable for the operation mode.

YCH 4-Pipe Scroll Units

- Low GWP Refrigerant: R454B (also R410A available as option)
- Plate Heat Exchanger
- High Efficiency: TER up to 7.6
- Domestic Hot Water Up to **55°C**
- Different Noise Levels: Standard – Silent – Super Silent
- EC Inverter Fans with High Available Static Pressure
- Full Control with Web Monitoring (option)
- Compact Systems, easier installation

YCH uses two separate and independent water circuits with dedicated plate heat exchangers: one for cooling and the other for heating.

Working configurations:

		Cooling only	
		Heating only	
		Domestic Hot Water production only	
		Cooling + Heating	
		Cooling + Domestic Hot Water production	
			Heating + Domestic Hot Water production
			Cooling + Heating + Domestic Hot Water production

4-Pipe Multifunctional units with Scroll compressors and plate exchangers

YCH-SRL-4P 0050 to 0590



Technical features (R454B)

YCH_SRL-4P model			0050	0060	0070	0075	0085	0105	0120	0135	0140	0185
Cooling only ¹	Cooling Capacity	kW	46.5	53.5	60.5	69.1	78.3	91.0	105.3	116.8	128.3	160.9
	Absorbed power	kW	16.4	18.8	21.5	23.9	27.4	32.4	37.0	40.0	45.5	57.6
	EER		2.84	2.84	2.81	2.89	2.86	2.81	2.85	2.92	2.82	2.79
	SEER ²		4.13	4.14	4.13	4.16	4.15	4.13	4.11	4.11	4.13	4.1
Heating only ³	Heating Capacity	kW	50.1	57.3	64.3	72.5	82.6	100.8	117.1	128.6	136.3	176.6
	Absorbed power	kW	15.4	18.0	20.5	22.6	25.6	30.5	35.1	38.7	41.2	53.9
	COP		3.25	3.18	3.14	3.21	3.23	3.31	3.34	3.32	3.31	3.28
	SCOP ⁴		3.46	3.43	3.33	3.33	3.35	3.5	3.51	3.6	3.69	3.52
Cooling + Heating ⁵	Cooling Capacity	kW	47.5	54.1	60.2	68.7	79.7	93.8	107.2	118.7	134.1	165.7
	Heating Capacity	kW	62.5	71.1	79.4	90.6	104.4	122.2	139.8	155.0	173.8	215.1
	Absorbed power	kW	15.2	17.3	19.5	22.2	25.1	29.0	33.1	36.9	40.5	50.4
	TER		7.25	7.25	7.15	7.18	7.34	7.46	7.47	7.41	7.60	7.55
Performance	Airflow	m/s	5.1	6.3	8.9	9.5	9.5	9.5	11.3	11.3	12.2	16.5
	Sound power level	dB(A)	80.9	81.7	81.9	83.0	83.1	84.5	85.8	86.2	87.9	88.9
Refrigerant	Type		R454B									
	Refrigerant charge		15.0	16.0	16.0	18.0	19.0	27	27	30	35	41
Dimensions and weight	Height	mm	1920	1920	1920	2220	2220	2220	2220	2220	2220	2220
	Length	mm	2350	2350	2350	2350	2350	2350	2350	3550	3550	3550
	Width	mm	1100	1100	1100	1100	1100	1100	1100	1100	1100	1100
	Operating weight	kg	769	778	832	931	959	1057	1102	1330	1348	1537

YCH_SRL-4P model			0180	0205	0230	0260	0280	0320	0380	0440	0480	0540	0590
Cooling only ¹	Cooling Capacity	kW	160.0	182.0	209.0	231.0	253.1	288.6	318.3	369.2	410.4	452.6	486.3
	Absorbed power	kW	55.6	67.2	73.0	82.7	90.5	101.1	113.0	125.8	139.6	161.9	182.6
	EER		2.88	2.71	2.86	2.79	2.80	2.85	2.82	2.94	2.94	2.80	2.66
	SEER ²		4.1	4.18	4.14	4.13	4.18	4.15	4.12	4.15	4.29	4.33	4.34
Heating only ³	Heating Capacity	kW	172.8	195.8	221.8	246.7	269.8	305.3	363.8	421.4	458.9	519.4	563.5
	Absorbed power	kW	53.1	61.7	69.4	76.1	82.8	93.4	108.9	124.4	137.8	152.2	168.6
	COP		3.26	3.17	3.20	3.24	3.26	3.27	3.34	3.39	3.33	3.41	3.34
	SCOP ⁴		3.48	3.33	3.61	3.54	3.4	3.59	3.36	3.23	3.4	3.56	3.6
Cooling + Heating ⁵	Cooling Capacity	kW	162.8	186.9	205.1	233.0	258.9	290.5	321.2	370.1	409.4	470.8	518.9
	Heating Capacity	kW	211.5	245.1	270.1	305.6	337.3	380.6	422.8	483.3	536.2	611.1	674.5
	Absorbed power	kW	49.4	59.2	66.0	73.9	80.0	91.6	103.4	115.3	129.2	143.3	158.4
	TER		7.57	7.30	7.20	7.29	7.46	7.33	7.19	7.40	7.32	7.55	7.53
Performance	Airflow	m/s	22.4	22.4	21.3	21.3	21.3	23.6	32.3	42.6	42.6	42.6	53.0
	Sound power level	dB(A)	88.7	89.0	89.8	89.9	90.2	92.4	93.7	94.2	94.3	96.0	97.2
Refrigerant	Type		R454B										
	Refrigerant charge		50.0	52.0	60.0	64.0	66.0	76.0	88.0	110.0	110.0	140.0	140.0
Dimensions and weight	Height	mm	2100	2100	2100	2100	2100	2100	2100	2100	2100	2100	2100
	Length	mm	3350	3350	3350	3350	3350	5000	5000	6200	6200	6200	7200
	Width	mm	2200	2200	2200	2200	2200	2200	2200	2200	2200	2200	2200
	Operating weight	kg	2353	2379	2497	2549	2579	3362	3607	4544	4724	4772	4879

1. Cooling capacities in kW given for 12/7°C water leaving temperature Δt 5°C and 35°C ambient temperature.
2. Seasonal energy efficiency of cooling at low temperature. According to EU Regulation n. 2016/2281.
3. Heating capacities in kW given for 40/45°C water leaving temperature and 7°C ambient temperature.
4. Seasonal energy efficiency of heating at low temperature with average climatic conditions. According to EU Regulation n. 813/2013.
5. Chilled water from 12 to 7 °C, heated water from 40 to 45 °C.

The above table only shows the performance of YCH units operating with R454B refrigerant although they are also available with R410A. For more information, please contact your Johnson Controls representative.



Manufacturer reserves the rights to change specifications without prior notice.

YCH

4-Pipe Multifunctional units with Inverter Screw compressors, EC Inverter fans and shell and tube exchangers

Cooling capacities from 268.3 kW to 1154.5 kW
 Heating capacities from 348.4 kW to 1455.3 kW



Multifunctional Operation

Simultaneous production of cooling, heating and domestic hot water

On complex buildings where there is simultaneous need of cooling and heating, YCH is capable to provide them at the same time with the maximum efficiency in every season of the year.

YCH allows to combine the three contemporary functioning modes – cooling, heating and domestic hot water production – to reach several working configurations.

Besides the standard components of a traditional chiller, the units are equipped with three exchangers (plate heat exchanger on cooling side, plate heat exchanger on heating side and finned coil exchanger on the disposable side) and a refrigerant circuit, which configuration varies depending on the type of request of the system. This is made possible by a series of solenoid valves, controlled by a microprocessor, which diverts the refrigerant flow in the exchanger suitable for the operation mode.

YCH 4-Pipe Screw Units

- Low GWP Refrigerant: R513A (also R134a available as option)
- Shell & Tube Heat Exchanger
- High Efficiency: TER up to 8.7
- Domestic Hot Water Up to **50°C**
- Different Noise Levels: Standard – Silent – Super Silent
- EC Inverter Fans with High Available Static Pressure
- Full Control with Web Monitoring (option)
- Compact Systems, easier installation
- Inverter
 - Screw Inverter compressor(s) as standard
 - EC fans as standard (or EC Fans with High Available Static Pressure & Efficiency as option)
 - Inverter water pumps as option

Working configurations:

		Cooling only
		Heating only
		Domestic Hot Water production only
		Cooling + Heating
		Cooling + Domestic Hot Water production
		Heating + Domestic Hot Water production
		Cooling + Heating + Domestic Hot Water production

4-Pipe Multifunctional units with Inverter Screw compressors, EC Inverter fans and shell and tube exchangers

YCH-SCJ-4P 0285 to 1160



Technical features (R513A)

YCH_SCJ-4P model			0285	0320	0375	0430	0490	0570	0670	0840	0990	1160
Cooling only ¹	Cooling Capacity	kW	271.2	304.2	357.1	412.8	472.4	550.6	660.0	802.6	955.0	1106.3
	Absorbed power	kW	85.9	96.8	112.7	129.1	148.6	171.8	203.1	249.9	305.4	354.7
	EER		3.16	3.14	3.17	3.20	3.18	3.20	3.25	3.21	3.13	3.12
	SEER ²		4.68	4.68	4.68	4.7	4.69	4.7	4.73	4.7	4.67	4.67
Heating only ³	Heating Capacity	kW	277.0	313.3	367.0	421.8	479.5	559.8	657.6	819.8	968.4	1130.7
	Absorbed power	kW	82.7	87.6	103.2	117.6	134.1	153.6	182.6	222.6	261.2	301.7
	COP		3.35	3.58	3.56	3.59	3.58	3.64	3.60	3.68	3.71	3.75
	SCOP ⁴		3.48	3.74	3.72	3.72	3.71	4.08	4.02	4.1	4.31	4.42
Cooling + Heating ⁵	Cooling Capacity	kW	268.3	310.6	361.3	418.7	481.9	562.4	670.0	816.7	973.4	1154.5
	Heating Capacity	kW	348.4	394.3	456.5	529.3	606.5	707.9	841.6	1026.9	1227.1	1455.3
	Absorbed power	kW	80.9	84.6	96.4	112.0	126.0	146.9	173.7	212.2	256.7	305.2
	TER		7.62	8.33	8.48	8.47	8.64	8.65	8.70	8.69	8.57	8.55
Performance	Airflow	m/s	29.2	29.2	38.3	40.6	47.8	50.6	61.7	80.0	80.0	80.0
	Sound power level	dB(A)	96.9	97.0	97.5	98.8	99.2	99.5	101.0	102.2	102.4	103.1
Refrigerant	Type		R513a									
	Refrigerant charge		110.0	115.0	155.0	195.0	235.0	310.0	355.0	375.0	400.0	440.0
Dimensions and weight	Height	mm	2100	2100	2100	2100	2100	2500	2500	2500	2500	2500
	Length	mm	5550	5550	6700	7750	8900	8900	10050	11100	11100	11100
	Width	mm	2200	2200	2200	2200	2200	2200	2200	2200	2200	2200
	Operating weight	kg	4630	4780	5580	6290	6790	7910	9360	10620	11140	12170

1. Cooling capacities in kW given for 12/7°C water leaving temperature Δt 5°C and 35°C ambient temperature.
2. Seasonal energy efficiency of cooling at low temperature. According to EU Regulation n. 2016/2281.
3. Heating capacities in kW given for 40/45°C water leaving temperature and 7°C ambient temperature.
4. Seasonal energy efficiency of heating at low temperature with average climatic conditions. According to EU Regulation n. 813/2013.
5. Chilled water from 12 to 7 °C, heated water from 40 to 45 °C.

The above table only shows the performance of YCH units operating with R513A refrigerant although they are also available with R134a. For more information, please contact your Johnson Controls representative..

Inverter Control on Screw Compressor(s)

Designed for high temperature applications: high power and efficiency

- High efficiency screw Rotor profile - hyper volumetric efficiency.
- High efficiency motor.
- Capacity control with Inverter regulation.
- ECONOMIZER.
- Low friction components: high reliability and efficiency.
- High performance INTEGRAL OIL SEPARATOR.

The screw compressor is managed by an **Inverter Variable Frequency Drive** that electronically modulates the compressor speed according to the required cooling load.

- Delivered & absorbed power is PROPORTIONALLY modulated on the compressor with Inverter.
- No step regulation.
- Minimized absorbed power when working at part load.



Manufacturer reserves the rights to change specifications without prior notice.

YHA

High efficiency air to water heat pumps (4 pipes)

Cooling capacities from 18.1 kW to 417 kW

Heating capacities from 23 kW to 478 kW



Features

The **YHA** series of high efficiency heat pumps has been specifically designed for use with radiant floor heating systems or those applications where it is necessary to have maximum efficiency when heating.

They have been optimized on heating mode, are able to produce water up to 60°C and can operate down to -20°C ambient temperature.

All versions are supplied with reverse cycle valve (**RV**) used for winter defrost. The **RV** versions are also able to produce cold water.

The noise is extremely low thanks to the use of a special floating vibration damping system which allows a noise reduction of about 10-12 dB(A) (Optional).

Available versions

SA	Standard efficiency (AC fans)
SE	Standard efficiency (EC fans)
HA	High efficiency (AC fans)
HE	High efficiency (EC fans)
RV	Reversible heating/cooling
LS	Low noise
XL	Super low noise
P4U	4 pipe systems heating/cooling
P4S	2+2 pipe systems with domestic hot water production

High efficiency air to water heat pumps (4 pipes)

YHA 242 to 5004



Nominal capacity

YHA HE/LS/RV - P4S version		242	292	412	432	492	602	702	802	902	1002	1202	1402	
Heating capacity (EN14511) (1)	kW	23	30.5	37.3	47.1	50.8	63.5	69.8	75.2	96.8	109	119	142	
Total input power (EN14511) (1)	kW	5.4	7.21	8.8	11.5	11.8	13.4	15.2	16.9	21.4	24.8	28.2	31.2	
COP (EN14511) (1)		4.26	4.23	4.24	4.1	4.31	4.74	4.59	4.45	4.52	4.4	4.22	4.55	
Energy Class (2)		A++	A++	A++	A++	A++	A++	A++	A++	A++	A++	A++	A++	
SCOP (2)		3.92	3.93	3.85	3.85	3.92	4.2	4.12	4.06	3.92	3.91	3.92	3.92	
$\eta_{s,h}$ (2)		154	154	151	151	154	165	162	159	154	153	154	154	
Cooling capacity (EN14511) (3)	kW	18.1	24.6	30.5	40.6	44.2	52.4	57.5	63.4	80.5	90.2	104	117	
Total input power (EN14511) (3)	kW	6.9	9.5	11	14.5	16.1	18.3	21.3	23.9	26.6	31.2	35.1	38.6	
EER (EN14511) (3)		2.62	2.59	2.77	2.8	2.75	2.86	2.7	2.65	3.03	2.89	2.96	3.03	
TER (EN14511) (3)		9.2	9.64	9.71	10.1	10.5	10.7	10.6	10.5	9.89	9.66	10.3	9.93	
Sound power (4)	dB (A)	78	79	79	80	79	80	81	82	86	87	88	89	
Sound pressure (5)	dB (A)	46	47	47	48	47	48	49	50	54	55	56	57	
Power supply	V/Ph/Hz	400/3/50												
Compressors / Circuits	n° / n°	2 / 1												
Fans	n°	2 / 2 / 2 / 2 / 2 / 2 / 2 / 2 / 2 / 2 / 2 / 2 / 3												
Dimensions	Height	mm	1500	1500	1690	1690	1690	1880	1880	1880	1880	1880	1880	1880
	Length	mm	1915	1915	2400	2400	2400	2905	2905	2905	2905	2905	2905	2905
	Width	mm	875	875	1150	1150	1150	1150	1150	1150	1150	1150	1150	1150
Weight	kg	560	560	670	690	720	1060	1060	1070	1120	1160	1240	1560	

YHA HE/LS/RV - P4S version		1602	1802	2002	2302	2502	2504	3004	3204	3504	4004	4504	5004	
Heating capacity (EN14511) (1)	kW	156	174	190	217	248	237	280	308	341	376	420	478	
Total input power (EN14511) (1)	kW	34.8	39.5	44.7	50	55.3	57	65.6	72	81.6	91	107	117	
COP (EN14511) (1)		4.48	4.41	4.25	4.34	4.48	4.16	4.27	4.28	4.18	4.13	3.93	4.09	
Energy Class (2)		A++	A++	A++	A++	A++	A++	A++	A++	A++	A++	A++	A++	
SCOP (2)		3.92	3.98	3.98	4	4.08	3.86	3.91	3.94	4.01	3.89	3.88	3.9	
$\eta_{s,h}$ (2)		154	156	156	157	160	151	153	155	157	153	152	153	
Cooling capacity (EN14511) (3)	kW	129	147	159	180	202	198	231	260	289	323	369	417	
Total input power (EN14511) (3)	kW	44	50.8	58.7	66.1	73.2	72.7	80.5	89.2	105	118	135	117	
EER (EN14511) (3)		2.93	2.89	2.71	2.72	2.76	2.72	2.87	2.91	2.75	2.74	2.73	2.69	
TER (EN14511) (3)		9.94	10.1	9.91	9.8	9.91	9.13	9.07	9.62	9.7	9.62	9.55	9.41	
Sound power (4)	dB (A)	89	90	90	92	92	91	91	92	92	93	95	94	
Sound pressure (5)	dB (A)	57	58	58	60	60	59	59	60	60	61	63	62	
Power supply	V/Ph/Hz	400/3/50												
Compressors / Circuits	n° / n°	2 / 1						4 / 2						
Fans	n°	3	3	3	3	3	4	6	6	6	6	8	8	
Dimensions	Height	mm	1880	1880	1880	2270	2270	2350	2350	2350	2350	2380	2380	2380
	Length	mm	3905	3905	3905	3905	3905	4205	4205	4205	4205	4805	4810	4810
	Width	mm	1150	1150	1150	1150	1150	2210	2210	2210	2210	2210	2210	2210
Weight	kg	1580	1600	1620	1790	1820	3170	3220	3270	3320	3660	3720	3780	

- (1) Heating: Ambient temperature 7°C DB, 6°C WB, water temperature 30/35°C.
 - (2) Average conditions, low temperature, variable - Reg EU 811/2013
 - (3) Cooling: ambient air temperature 35°C, evaporator water temperature in/out 12/7 °C.
 - (4) Sound power level in accordance with ISO 3744.
 - (5) Sound pressure level at 10 m from the unit in free field conditions in accordance with ISO 3744.
- For information about other YHA versions, contact your JCI representative.

Operating limits

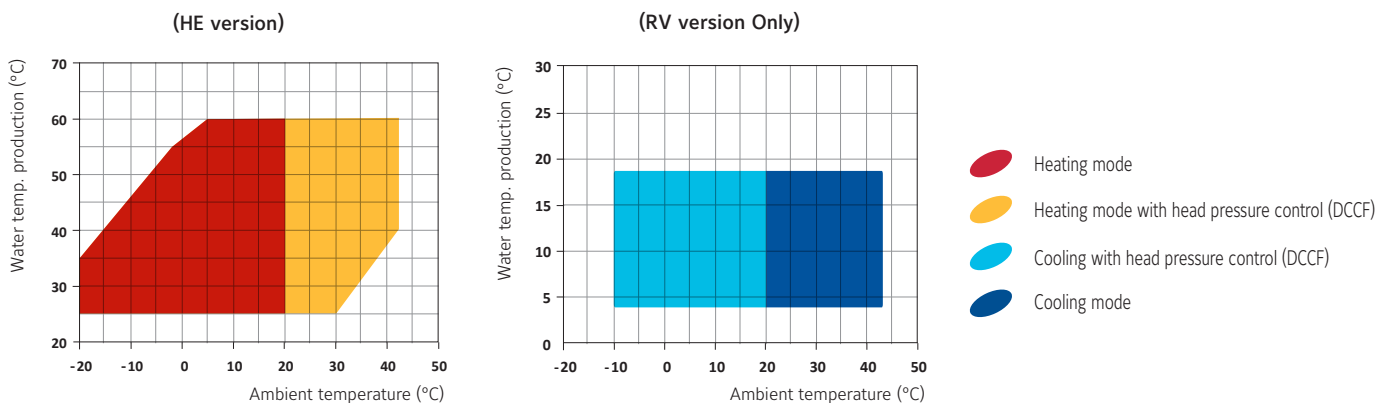

Manufacturer reserves the rights to change specifications without prior notice.

YLZ

High efficiency air to water heat pumps with E.V.I. compressors (4 pipes)

Cooling capacities from 22.9 kW to 180.1 kW
 Heating capacities from 24 kW to 209.6 kW



Features

The **YLZ** series of high efficiency heat pumps has been specifically designed for use with radiant floor heating systems or those applications where it is necessary to have maximum efficiency when heating.

They have been optimized on heating mode, are able to produce water up to 65°C and can operate down to -20°C ambient temperature.

All versions are supplied with reverse cycle valve (**RV**) used for winter defrost. The **RV** versions are also able to produce cold water.

The noise in **XL** and **NN** versions is extremely low thanks to the use of a special floating vibration damping system which allows a noise reduction of about 10-12 dB(A).

Optional

- High Pressure ducted fans option (Available ESP 150 Pa).
- Additional height of the unit due to ducting option: 150 mm

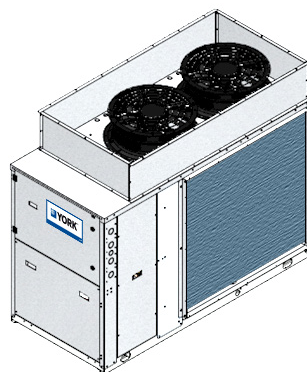

Available versions

SA	Standard efficiency (AC fans)
SE	Standard efficiency (EC fans)
HA	High efficiency (AC fans)
HE	High efficiency (EC fans)
RV	Reversible heating/cooling
XL	Super low noise
NN	Ultra low noise
P4U	4 pipe systems heating/cooling
P4S	2+2 pipe systems with domestic hot water production

High efficiency air to water heat pumps with E.V.I. compressors (4 pipes)

YLZ 252 to 2154

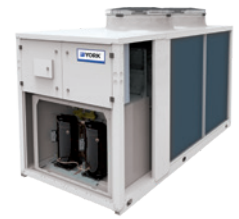

Nominal capacity

YLZ HE/LS/RV - P4U/P4S - Reversible version		252	302	432	492	602	752	852	1002	1202	1454	1654	1854	2154	
Heating capacity (EN14511) (1)	kW	24	29.5	41.8	50.3	58.3	66.9	81.3	88.5	102.7	145.2	163.2	181.3	209,6	
Total input power (EN14511) (1)	kW	5.2	6.7	9.5	12.2	12.8	15.3	18.9	20.6	24.6	33.4	38.9	41.9	50,5	
COP (EN14511) (1)		4.61	4.38	4.40	4.12	4.56	4.37	4.31	4.31	4.17	4.35	4.19	4.33	4,15	
Energy Class in low temperature (2)		A++	A++	A++	A++	A++	A++	A++	A++	A++	A++	A++	A++	A++	
SCOP low temperature (2)		4.10	3.96	3.87	3.83	4.08	4.06	3.83	3.85	3.84	3.88	3.88	3.89	3,89	
ηs,h low temperature (2)		161	156	152	150	160	159	150	151	151	152	152	153	153	
Energy Class in medium temperature (2)		A++	A++	A+	A+	A++	A++	A+	A+	A+	A+	A+	A+	A+	
SCOP medium temperature (2)		3.25	3.21	3.12	3.15	3.29	3.23	3.07	3.14	3.13	3.10	3.15	3.17	3,19	
ηs,h medium temperature (2)		127	125	122	123	129	126	120	123	122	121	123	124	124	
Cooling capacity (EN14511) (3)	kW	22.9	30.2	37.5	45.6	52.9	62.5	71.6	78.2	90.8	126.8	142.8	157.0	180,1	
Total input power (EN14511) (3)	kW	7.0	8.8	12.7	16.7	17.9	21.3	24.4	26.1	31.3	42.0	50.5	53.4	66,2	
EER (EN14511) (3)		3.27	3.42	2.96	2.73	2.95	2.64	2.94	3.00	2.90	3.02	2.83	2.94	2,72	
Sound power (4)	dB (A)	78	78	78	79	80	80	83	83	83	84	85	85	85	
Sound pressure (5)	dB (A)	46	46	46	47	48	48	51	51	51	52	53	53	53	
Power supply	V/Ph/Hz	400/3/50													
Compressors / Circuits	n° / n°	2 / 1						4 / 2							
Fans	n°	2	2	2	2	2	2	2	2	2	3	3	3	3	
Dimensions	Height	mm	1490	1490	1670	1670	1840	1840	1840	1840	1840	1895	1895	1895	1895
	Length	mm	1915	1915	2400	2400	2905	2905	2905	2905	2905	4695	4695	4695	4695
	Width	mm	875	875	1145	1145	1145	1145	1145	1145	1145	1145	1145	1145	1145
Weight	kg	1000	1000	1500	1500	2000	2000	2000	2000	2000	2580	2640	2720	2760	

- (1) Heating: Ambient temperature 7°C DB. 6°C WB. water temperature 30/35°C.
 - (2) Average conditions. variable - Reg EU 811/2013
 - (3) Cooling: ambient air temperature 35°C. evaporator water temperature in/out 12/7 °C.
 - (4) Sound power level in accordance with ISO 3744.
 - (5) Sound pressure level at 10 mt from the unit in free field conditions in accordance with ISO 3744.
- For information about other YLZ versions. contact your JCI representative.

Operating limits

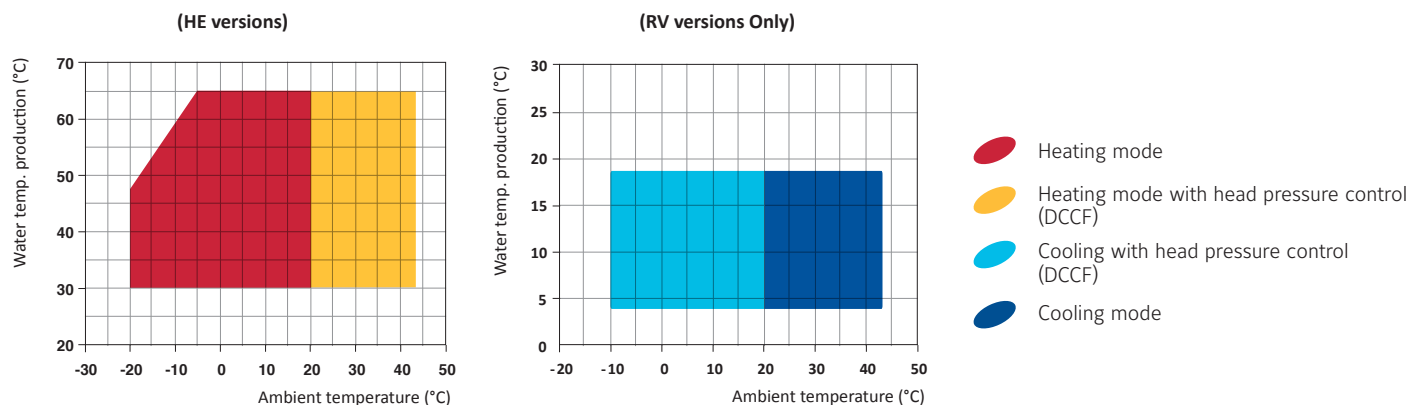

Manufacturer reserves the rights to change specifications without prior notice.

YLAA

Air Cooled Scroll Chiller with HFO (R454B)

Extended cooling capacities from 195 kW to 635 kW



Features

The **YORK YLAA TEMPO** air-cooled chiller is an environmental leader.

Utilising scroll type compressors and microchannel condenser coil technology the **YLAA** delivers premium efficiency for all air conditioning applications.

YLAA chillers are a self-contained cooling solution that is light-weight and compact for convenient installation on the ground or on building rooftops.

Options/Accessories

- Variable speed EC fans
- Hydrokits with fixed or variable speed pump (single or dual)
- Soft start
- Power factor correction capacitors
- Low ambient kit
- BMS interfacing options
- Dual pressure relief valves
- Victaulic coupling
- Flow switch
- Heat recovery option
- Enclosure options
- Sound attenuation options
- Anti-vibration mounts options
- Epoxy post-coated dipped microchannel coils

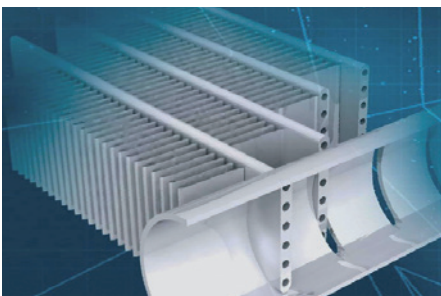

The TEMPO delivers energy efficiency levels that surpasses Ecodesign Tier 2 requirements. Aluminium microchannel condenser coil technology is one reason for this premium efficiencies.

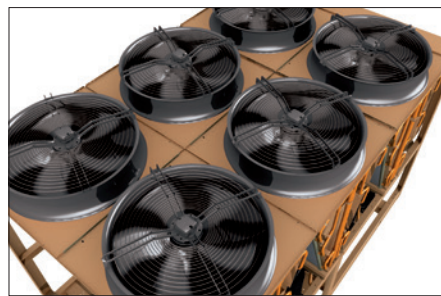

Ultra quiet operation and outstanding part load efficiency can be obtained through variable speed EC fans and a compressor acoustic blankets.

A single point power connection and optional, factory packaged water pumps, water filter and flow switch provide fast and easy installation.

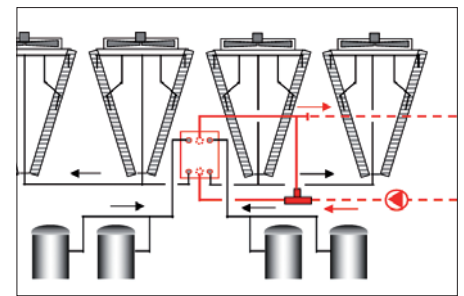

An optional heat recovery feature can be added to provide hot water to 60°C; which is useful for facility heating or hot water preheating.

Air-cooled scroll compressor chiller

YLAA 0195 to 0640



Nominal capacity

YLAA	0195*	0221	0262	0286	0301	0350	0392	0442	0457	0517	0580	0640
Cooling capacity (kW)	195.4	211.3	246.5	275	298.8	347.9	376.8	432.8	462.1	531	572.9	635.4
EER	3.17	3.38	3.24	2.79	3.17	3.06	3.1	3.05	3.05	3.1	3.2	3.17
SEER	4.48	4.9	4.62	4.49	4.82	4.78	4.78	4.89	5.04	5.12	5.25	5.31
η_s, c	176.1	192.9	181.6	176.7	189.7	188.1	188.4	192.5	198.6	201.7	207.1	209.4
Sound power level dB(A)	91	89	89	89	90	92	91	92	92	93	94	96

Net values at Eurovent nominal conditions:

Cooling capacities in kW given for 7°C water leaving temperature Δt 5°C and 35°C ambient temperature.

Ecodesign figures are calculated following variable water and variable outlet approach (VW/VO). For other Ecodesign calculations, please contact your JCI representative.

(* All models have R454B refrigerant, EC fans (except size 0195) and Compressor Sound Blankets.

The above data is based on Johnson Controls' selection software Selection Navigator SN25.03. Please refer to the latest version of the software for specific projects.

Technical data

YLAA			0195	0221	0262	0286	0301	0350	0392	0442	0457	0517	0580	0640
Dimensions	Length	mm	2911				3690				4807		5880	7000
	Width	mm	2242				2254				2258			
	Height	mm	2508				2541							
Operating weight kg			1706	1721	1852	1853	2170	2339	2508	3343	3481	3615	4252	4474

YLAA Pump Kit

- Fixed or VSD water pump
- Single or Dual water pump
- Two option levels - basic and full featured - for maximum flexibility
- More impeller size options for better match to customer requirements
- New, smaller pump motors suitable for primary-secondary systems

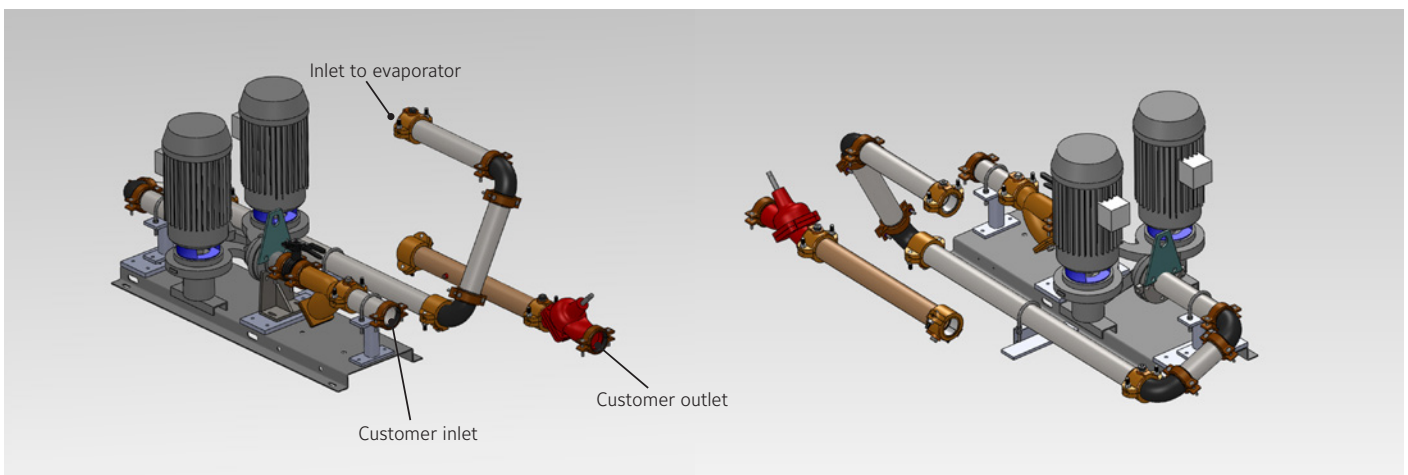

Manufacturer reserves the rights to change specifications without prior notice.

Dimensions and hydraulic connections

YLAA 0195, 0221 and 0262

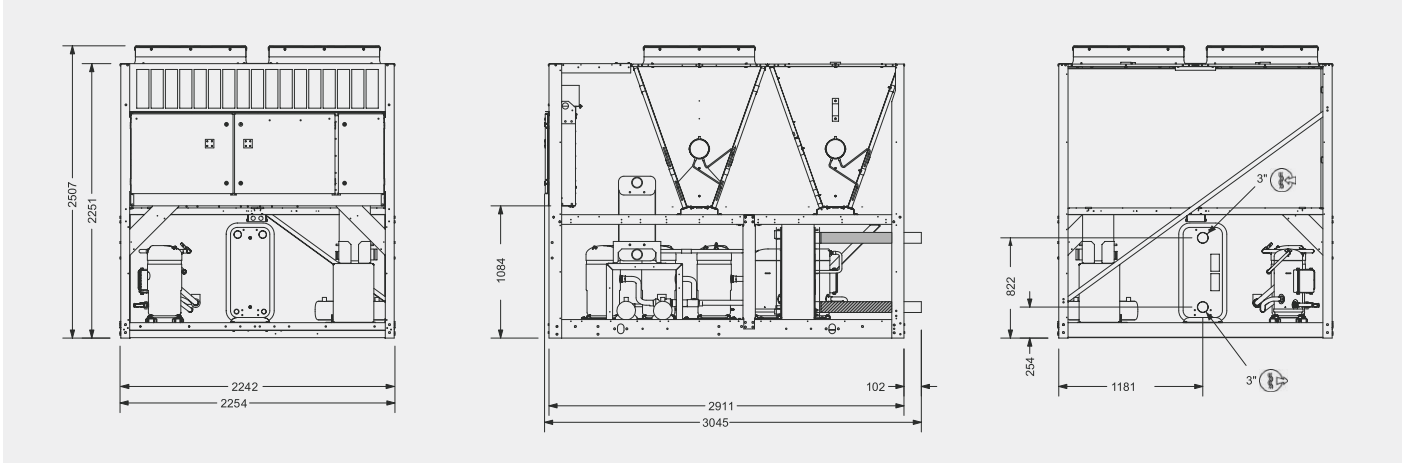

All dimensions in mm. Drawings not in scale.

YLAA 0301 and 0392

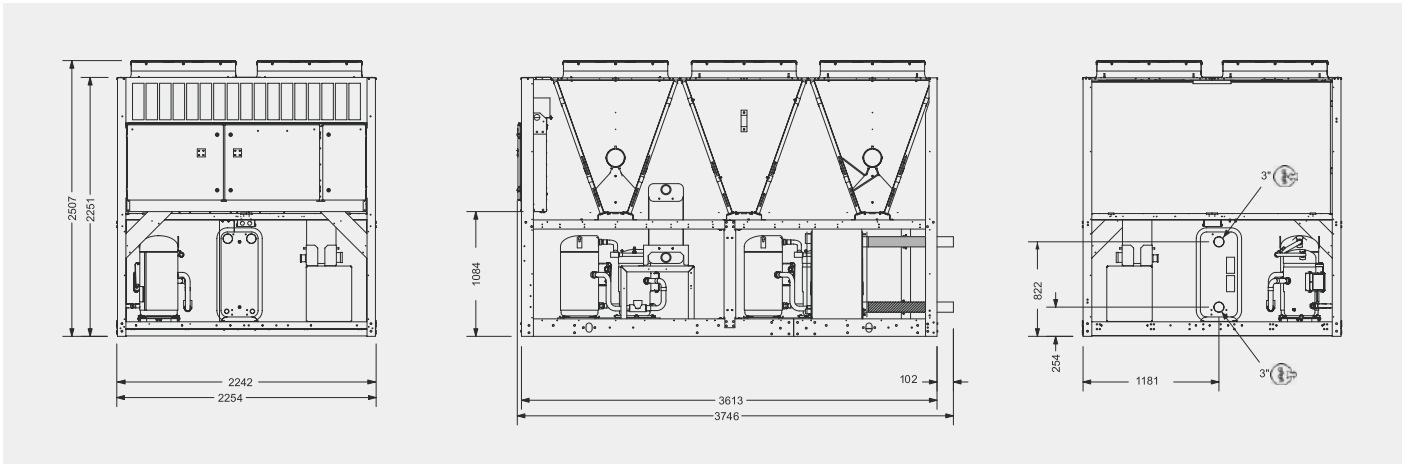

All dimensions in mm. Drawings not in scale.

YLAA 0442

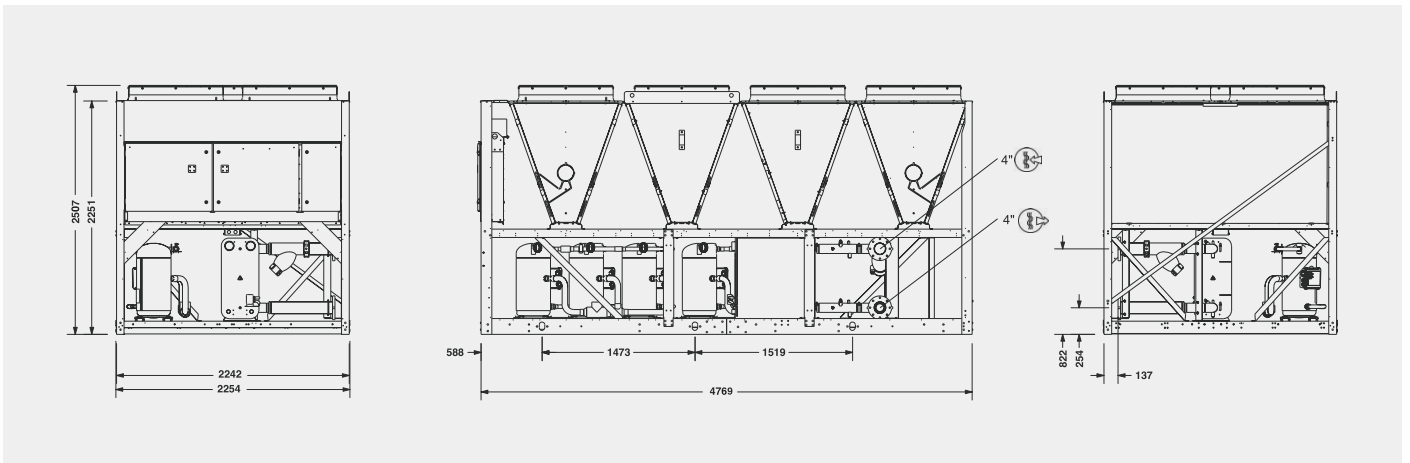

All dimensions in mm. Drawings not in scale.

YLAA 0195 to 0640



YLAA 0457 and 0517

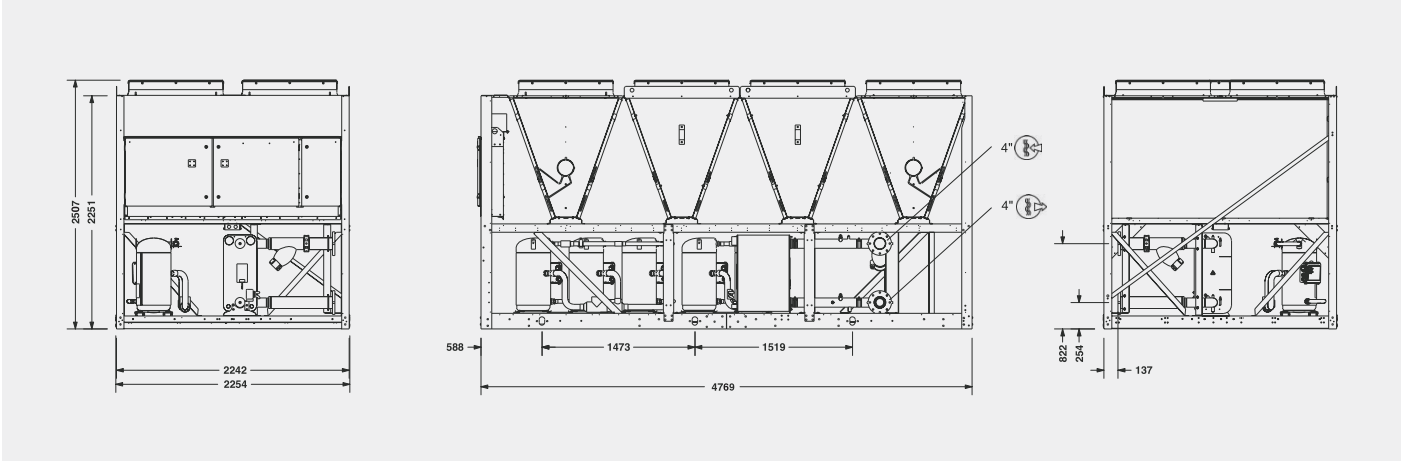

All dimensions in mm. Drawings not in scale.

YLAA 0580

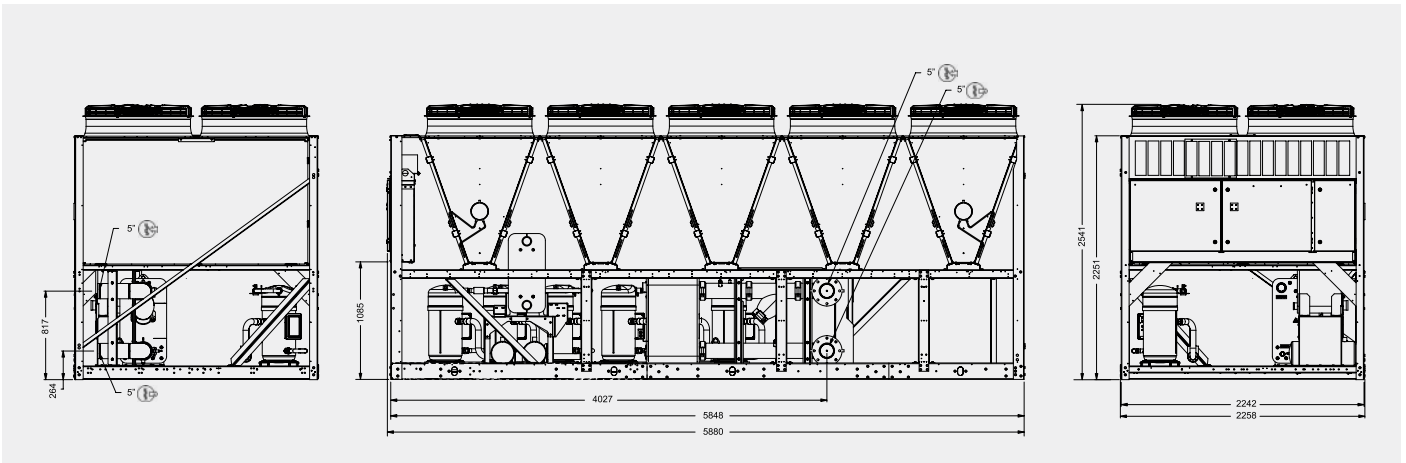

All dimensions in mm. Drawings not in scale.

YLAA 0640

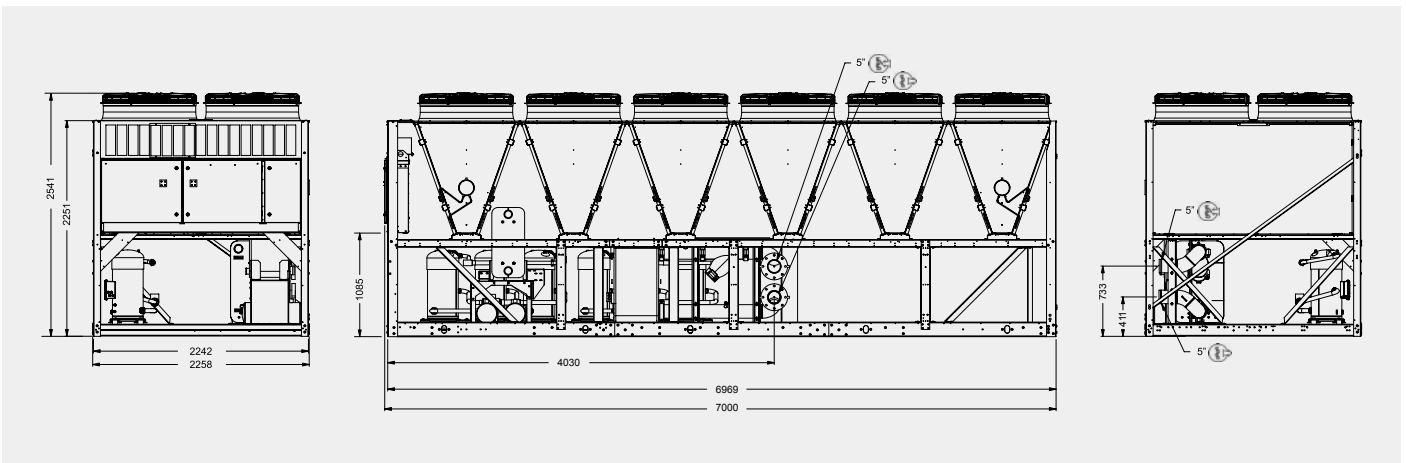

All dimensions in mm. Drawings not in scale.

YGT

Air-cooled VSD screw chiller with HFO

Cooling capacities from 401 kW to 983 kW



Features

YORK® YGT premium efficiency air-cooled VSD screw chillers from Johnson Controls deliver class-leading efficiency at both full load and part load condition. Built upon decades of industry-leading chiller expertise, our next-generation air-cooled screw chiller portfolio provides lower operating costs, increased application flexibility, reduced sound levels, optimized controls and world-class reliability.

Thanks to the combination of high efficiency and the use of the new 4th generation HFO refrigerant R1234ze, the chiller SEER surpasses the Ecodesign Tier 2 requirement and contributes to the reduction of the Total Equivalent Warming Impact (TEWI).

Operating limits

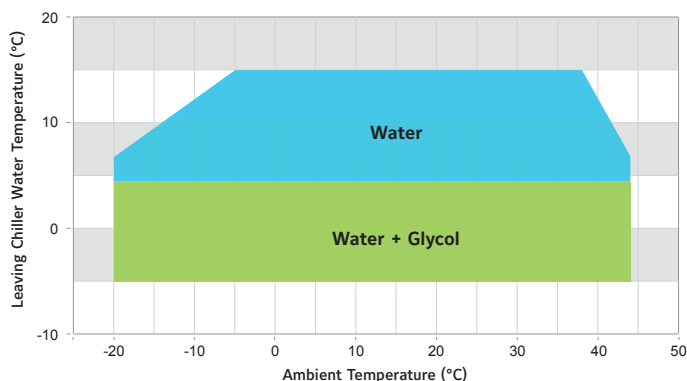

Design conditions requirements beyond above mentioned Operating Envelope can be reviewed and quoted as Special Quotes

Scope

- Capacity range: 401 to 983 kW
- Capacity sizes: 7 models
- Refrigerant R1234ze
- Ecodesign Tier 2 compliance
- Two efficiency levels: Single or Dual VSD
- Leak detector as standard

Options

- Full Heat Recovery (Special Request)
- Integrated Hydronic Kit (dual/high pressure pumps, buffer tank)
- Variable Speed Drive
- Low Sound configuration

Air-cooled VSD screw chiller with HFO

YGT0400 to 1000



Performances

YGT HE - High Efficiency - Single VSD		0400 HE	0450 HE	0550 HE	0650 HE	0800 HE	0900 HE	1000 HE
Cooling capacity	kW	401.0	415.9	535.3	652.7	796.0	880.6	983.1
EER		3.16	3.17	3.13	3.08	3.08	3.16	3.13
SEER		4.80	4.84	4.70	4.75	4.80	4.90	4.89
$\eta_{s,c}$		189.0	190.6	185.0	187.0	189.0	193.0	192.6
Power input	kW	127.1	131.3	171.2	212.1	258.3	278.3	314.0
Absorbed current	A	214.8	234.0	290.0	356.1	437.0	477.5	546.0
Number of compressors / circuits		1 / 1	2 / 2	2 / 2	2 / 2	2 / 2	2 / 2	2 / 2
Number of EC fans		8	10	10	12	14	18	18
Airflow	m ³ /h	156900	185060	200600	242000	286600	350200	363400
Water flow	m ³ /h	69.0	71.9	91.8	112.5	136.9	151.4	168.9
Pressure drop	kPa	34.3	36.8	26.6	28.7	27.8	32.2	26.5
Refrigerant charge	kg	80	90	100	120	140	170	175
Sound Power Level	dBA	94	96	97	97	98	99	99
Power supply		400V /3PH/ 50Hz						
Unit maximum operating current	A	422	490	630	774	835	998	1106
Unit peak current	A	614	881	775	977	1101	1347	1513

YGT XHE - Extra High Efficiency - Dual VSD		0450 XHE	0550 XHE	0650 XHE	0800 XHE	0900 XHE	1000 XHE
Cooling capacity	kW	415.9	535.3	652.7	796.0	880.6	983.1
EER		3.17	3.13	3.08	3.08	3.16	3.13
SEER		5.02	4.93	5.00	5.02	5.12	5.10
$\eta_{s,c}$		197.8	194.2	197.0	197.8	201.8	201.0
Power input	kW	131,3	171,2	212,1	258,3	278,3	314,0
Absorbed current	A	234,0	290,0	356,1	437,0	477,5	546,0
Number of compressors / circuits		2 / 2	2 / 2	2 / 2	2 / 2	2 / 2	2 / 2
Number of EC fans		10	10	12	14	18	18
Airflow	m ³ /h	185060	200600	242000	286600	350200	363400
Water flow	m ³ /h	71,9	91,8	112,5	136,9	151,4	168,9
Pressure drop	kPa	36,8	26,6	28,7	27,8	32,2	26,5
Refrigerant charge	kg	90	100	120	140	170	175
Sound Power Level	dBA	96	97	97	98	99	99
Power supply		400V /3PH/ 50Hz					
Unit maximum operating current	A	490	630	774	835	998	1106
Unit peak current	A	601	776	965	1027	1226	1361

Data calculated at Eurovent conditions. This data is subject to change without prior notice.

Cooling capacities in kW given for 12/7°C water leaving temperature and 35°C ambient temperature.

Ecodesign figures are calculated following variable water and variable outlet approach (VW/VO). For other Ecodesign calculations, please contact your JCI representative.

Technical data

YGT HE - High Efficiency - Single VSD		0400 HE	0450 HE	0550 HE	0650 HE	0800 HE	0900 HE	1000 HE
Dimensions	Length	mm	5060	6200	6200	7340	8480	10760
	Width	mm	2260					
	Height	mm	2600					
Weight	kg	4608	5511	6297	7290	7838	9027	9098

YGT XHE - Extra High Efficiency - Dual VSD		0450 XHE	0550 XHE	0650 XHE	0800 XHE	0900 XHE	1000 XHE	
Dimensions	Length	mm	6200	6200	7340	8480	10760	
	Width	mm	2260					
	Height	mm	2600					
Weight	kg	5583	6383	7312	7970	9159	9230	



Manufacturer reserves the rights to change specifications without prior notice.

New generation YVAA Air-cooled VSD screw chiller

Cooling capacities from 500 kW to 2000 kW

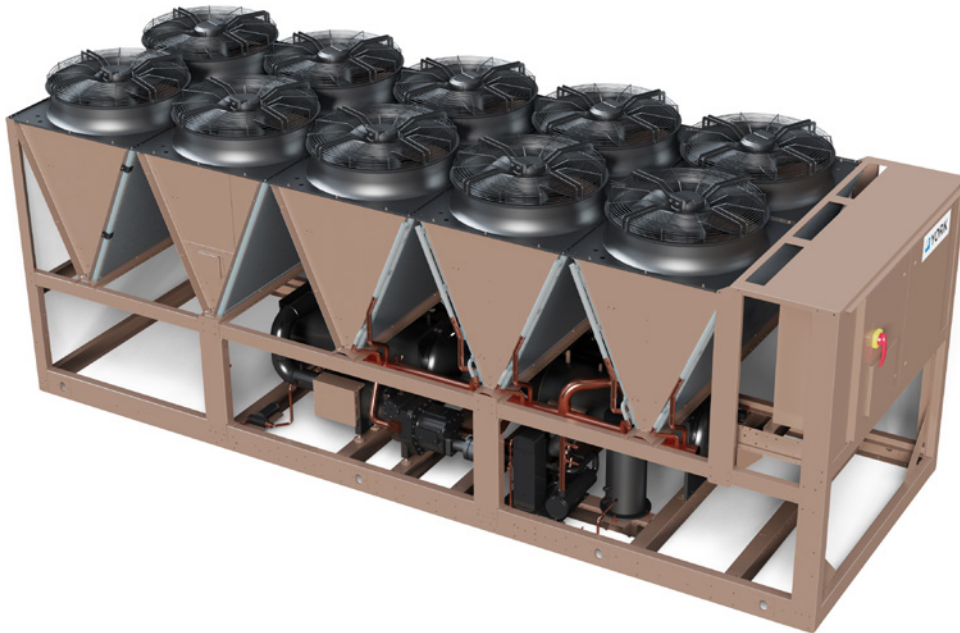

Also available with R134a



The new generation YVAA air-cooled, variable-speed drive screw chiller from YORK® is designed to improve reliability and performance through proven technology and a customizable, highly optimized design.

Features

- **Greater flexibility with configurability**
- **Reduced footprint with maintained performance**
- **Improved peak efficiency**
- **Sustainability. Minimise your environmental impact dramatically**

Options/Accessories

- BMS Interfacing options
- Advanced Controls (Silent Night, Quick Restart)
- Low temperature application options
- Dual pressure relief valves
- Flow switch
- Epoxy treatment Microchannel Coils
- Fan options
- Enclosure options
- Sound attenuation options
- Anti-vibration mounts options

Heat exchanger performance

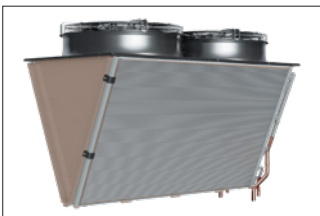

- Condenser design optimized for higher system efficiency
- New MCHX design improves heat transfer



- New brazed plate heat exchanger economizer

Series flow evaporator

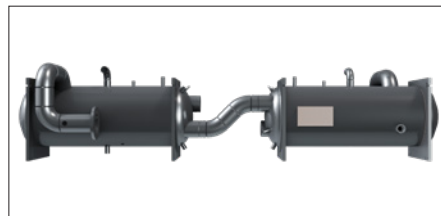

- Higher efficiency
- Greater flexibility for performance optimization
- -12°C to 21°C operating range

EC fan



- Higher efficiency with variable speed drive EC motor fan
- Containerized option – able to ship in a closed container saving freight cost
- Delivering real world annual energy consumption savings
- Sound Reduction

Air-cooled VSD screw chiller

YVAA-B 0571 to 1731



Application flexibility (*) example of selections

YVAA-B		0571	0586	0599	0616	0671	0686	0699	0701	0741	0754	0756	0769
Cooling capacity (R513A)	kW	529.5	544.5	589.5	599.5	644.4	679.3	689.4	699.3	719.3	739.3	749.3	759.2
EER (R513A)		3.09	3.20	3.21	3.25	3.11	3.13	3.22	2.88	3.06	3.15	3.19	3.29
SEER (R513A)		4.73	4.86	4.99	5.07	4.97	5.07	5.18	4.63	4.89	5.09	5.19	5.32
$\eta_{s,c}$ (R513A)		186	192	197	200	196	200	204	182	193	201	205	210
Sound power level	dBA	96	95	96	96	96	97	97	94	95	95	95	97
Cooling capacity (R1234ze)	kW	468.4	471.3	473.7	483.2	544.8	537.7	566.6	613.7	621.4	623.5	616.2	617.9
EER (R1234ze)		3.30	3.44	3.55	3.60	3.25	3.32	3.43	2.97	3.12	3.28	3.28	3.35
SEER (R1234ze)		4.99	5.14	5.27	5.36	5.11	5.19	5.33	4.88	5.06	5.24	5.31	5.41
$\eta_{s,c}$ (R1234ze)		196.6	202.6	207.6	211.6	201.4	204.5	210.3	192.2	199.2	206.7	209.5	213.3
Sound power level (R1234ze)	dBA	100	100	100	100	101	101	101	101	101	101	101	101

YVAA-B		0782	0796	0809	0824	0866	0894	0919	0921	0924	0936	0949	1034
Cooling capacity (R513A)	kW	779.3	789.3	799.2	819.2	859.2	899.1	909.1	919.3	929.1	949.3	969.3	1029
EER (R513A)		3.18	3.26	3.33	3.15	3.26	3.07	3.17	3.07	3.21	3.14	3.19	3.24
SEER (R513A)		5.19	5.30	5.43	5.23	5.45	5.19	5.33	5.22	5.45	5.34	5.46	5.47
$\eta_{s,c}$ (R513A)		205	209	214	206	215	205	210	206	215	211	216	216
Sound power level	dBA	98	98	97	96	96	98	97	97	97	99	98	98
Cooling capacity (R1234ze)	kW	649.2	651.3	653.4	701.3	705.5	754.7	756.1	761.4	758.2	762.8	764.9	860.6
EER (R1234ze)		3.31	3.40	3.47	3.28	3.43	3.28	3.36	3.30	3.43	3.38	3.44	3.30
SEER (R1234ze)		5.34	5.45	5.55	5.32	5.54	5.32	5.42	5.36	5.54	5.47	5.58	5.57
$\eta_{s,c}$ (R1234ze)		210.6	215.1	219	209.9	218.7	214.4	213.8	211.4	218.5	215.6	220.4	219.8
Sound power level (R1234ze)	dBA	101	101	101	101	102	102	102	102	102	102	102	103

YVAA-B		1076	1089	1134	1161	1174	1271	1381	1409	1549	1606	1649	1731
Cooling capacity (R513A)	kW	1079	1099	1139	1159	1189	1269	1379	1449	1549	1599	1699	1899
EER (R513A)		3.23	3.26	3.15	3.20	3.22	3.10	3.06	3.08	2.98	3.05	2.97	2.43
SEER (R513A)		5.54	5.58	5.35	5.43	5.51	5.43	5.41	5.52	5.37	5.51	5.49	4.87
$\eta_{s,c}$ (R513A)		219	220	211	214	218	214	213	218	212	218	217	192
Sound power level	dBA	99	99	100	99	98	98	99	100	100	100	101	110
Cooling capacity (R1234ze)	kW	862.7	864.8	958.3	960.1	962.2	1044.2	1143.0	1146.8	1326.6	1332.2	1336.1	-
EER (R1234ze)		3.36	3.40	3.17	3.24	3.30	3.16	3.09	3.19	2.92	3.02	3.07	-
SEER (R1234ze)		5.66	5.71	5.5	5.6	5.69	5.52	5.52	5.66	5.42	5.58	5.64	-
$\eta_{s,c}$ (R1234ze)		223.4	225.4	216.9	220.8	224.5	217.9	217.8	223.3	213.6	220.3	222.7	-
Sound power level (R1234ze)	dBA	103	103	104	104	104	106	106	106	108	108	108	-

Net values at Eurovent nominal conditions for models using R1234ze and R513A: Cooling capacities in kW given for 7°C water leaving temperature Δt 5°C and 35°C ambient temperature. SEER calculated according to EN14511 and EN14825.

Ecodesign figures are calculated following variable water and variable outlet approach (VW/VO). For other Ecodesign calculations, such as SEPR Medium and High temperature for process application, please contact your JCI representative.

(*) New generation YVAA is a tailor and tune chiller. Its performance will be factory-adjusted to match the exact site requirements based on the specific project operating conditions. The table above shows only a representative sample of performance points based on generic project operating conditions working with R1234ze and R513A refrigerants, optimized compressor and high efficiency fans Variable Speed EC motor.

For tailored and tuned performance based on your specific project requirements, and for more information, please contact your Johnson Controls representative. Please refer to the latest version of the software Selection Navigator SN24.12 for specific projects.

Technical data

YVAA-B		0571	0586	0599	0616	0671	0686	0699	0701	0741	0754	0756	0769	
Dimensions	Length	mm	5163	6274	7397		6274	7397		5163	6274	7397	8514	9631
	Width	mm	2243											
	Height *	mm	2358											
Operating weight	kg	5268	6122	6516	6946	6198	6592	7021	5841	6234	6628	7022	6957	
Refrigerant charge	kg	69/69	75/75	81/81	89/89	82/69	89/75	97/83	70/70	76/76	82/82	89/89	95/95	

YVAA-B		0782	0796	0809	0824	0866	0894	0919	0921	0924	0936	0949	1034
Dimensions	Length	mm	7397	8514	9631	7397	9631	7397	8514	7397	9631	8514	9631
	Width	mm	2243										
	Height *	mm	2358										
Operating weight	kg	6597	6992	7387	7100	7949	7114	7509	7913	7904	7847	8703	8962
Refrigerant charge	kg	90/90	97/97	103/103	102/84	115/97	96/96	102/102	103/103	109/109	109/109	115/115	124/109

YVAA-B		1076	1089	1134	1161	1174	1271	1381	1409	1549	1606	1649	1731
Dimensions	Length	mm	10748	11865	9631	10748	11865		14105	11865	14105	15222	11865
	Width	mm	2243										
	Height *	mm	2358										
Operating weight	kg	7957	8245	9122	8117	8405	9008	9160	9721	10919	11479	11769	10136
Refrigerant charge	kg	131/115	131/128	118/118	124/124	131/131	166/109	160/118	173/131	147/147	160/160	166/166	147/147

* The indicated height refers to the model with Standard fans.



Manufacturer reserves the rights to change specifications without prior notice.

Proven Technology

Over decades of use, and more than 22,000 units installed globally, the YVAA chiller has excelled in a variety of applications while defining what's possible in air-cooled chiller technology and durability. Our highly optimized component choices make the new generation YVAA a more flexible, more reliable option for energy-efficient cooling and sustainability.



Available with R1234ze

The YVAA chiller also is available with R-1234ze(E) refrigerant which has a very low global warming potential of 7.



Optimized compressors with patented, variable volume index (VI) technology

With decades of experience varying compressor speeds, the YVAA incorporates advanced, patented technology in a proven design. Our VI design optimizes the compression ratio of the compressor to match the conditions between the evaporator and condenser. This optimized compression ratio prevents over-compression to minimize energy consumption. Every compressor is run-tested at the end of the production line to ensure reliable operation.



Microchannel condenser coil

Carefully designed and tested for the unique conditions a building's HVAC system experiences, our next-generation microchannel heat exchangers use parallel flow aluminum alloy tubes that are easy to clean. Plus, our microchannel heat exchangers feature coating options that help increase reliability and durability in harsh environments.



EC and VSD Fans

Higher efficiency variable speed EC motor fans deliver energy consumption savings and sound reduction. VSD fans offer excellent efficiency with lower first cost and proven performance.



Quick Start

The optional Quick Start feature enables an industry-leading compressor restart of 34 seconds after power is restored. And because YVAA chillers contain a variable-speed drive, there is no inrush of current, so all compressors can be started together. This allows a faster ramp-up to full capacity than is possible with a typical chiller.



Smarter controls

Our built-in controls tolerate large variants in input power, shifts in liquid temperatures and changes in environmental conditions to maximize chiller uptime. And our controls integrate with industry standard Building Automation Systems (BAS) and the world-class Metasys controls system for greater building energy management efficiency. Optional Mobile Access Port (MAP) provides remote monitoring for predictive maintenance, resulting in dependable operation.



Variable-speed drive

Four decades ago, we introduced the first variable-speed drive (VSD) chiller. Our first VSD, air-cooled chiller came in 2004, and we've since installed more VSD chillers than all other manufacturers combined. VSDs help reduce energy consumption – particularly at off-design conditions – and can help lower annual energy costs as much as 50%. Our patented, liquid-cooled VSDs also require less maintenance, with glycol replacement required only every five years. And the variable-speed design dramatically reduces sound levels at offdesign conditions – up to 16 dBA. Designed and manufactured by Johnson Controls, a 100% liquid-cooled VSD is standard on the YVAA range.



Oil separator

The YVAA oil management system uses differential pressure to ensure proper oil flow and eliminate the need for mechanical oil pumps.



High-efficiency economizer

Our high-efficiency economizer boosts capacity, improves system efficiency and reduces operating costs.



Hybrid falling film series flow evaporator

A patented, hybrid falling film shell and tube style of series flow evaporators provides a higher energy efficiency, minimize refrigerant charge up to 15% and offer a greater flexibility for performance optimization. Also it allows a wide operating range (-12°C to 21°C).

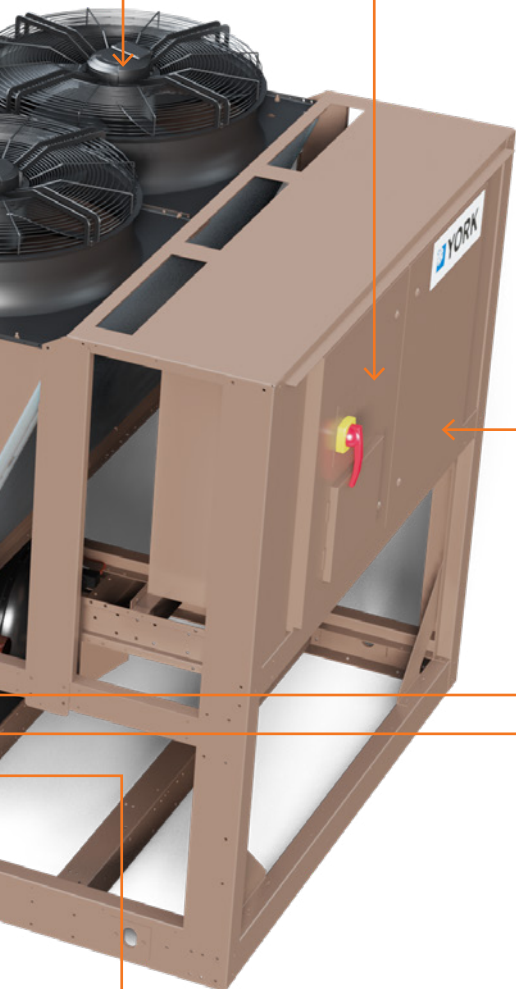

Dimensions and hydraulic connections

All drawings are for two pass evaporator. For other configurations, please, contact JCI.

YVAA-B 0571 and 0701

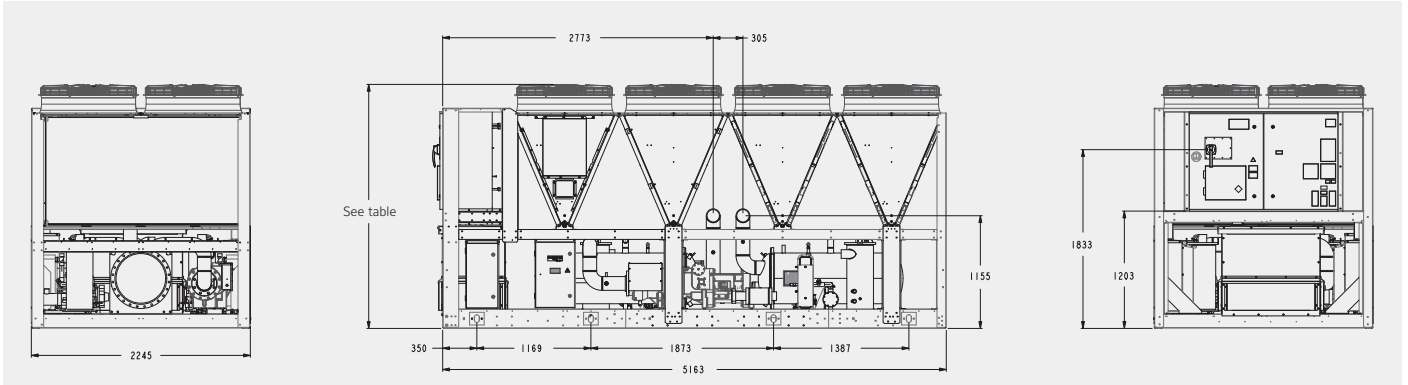

Unit height	EC Fans	Standard fans
YVAA-B 0571 & 0701	2501	2358

All dimensions in mm. Drawings not in scale. Dimensional drawings are for reference only. Actual dimensional drawings are specific to each unit selection. Please contact your JCI representative.

YVAA-B 0586, 0671 and 0741

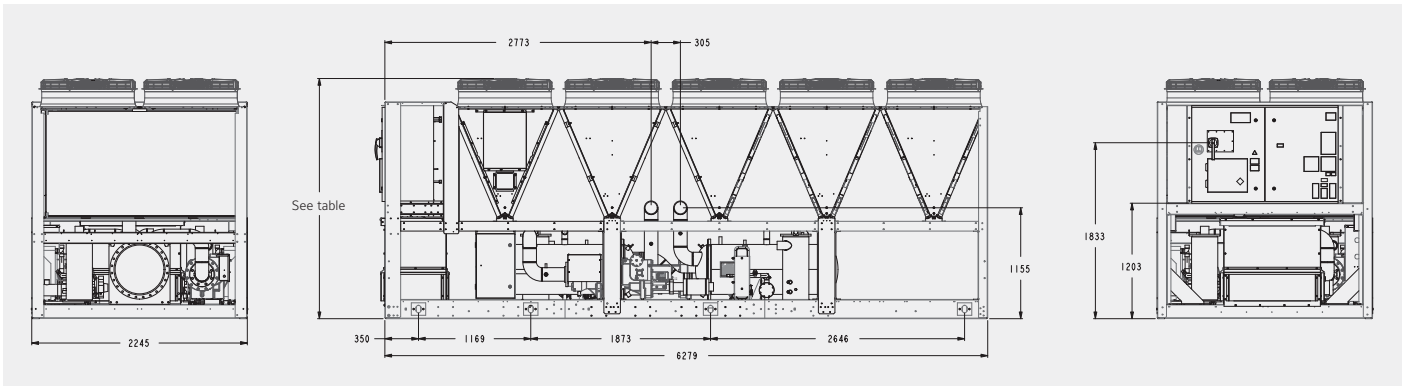

Unit height	EC Fans	Standard fans
YVAA-B 0586, 0671 & 0741	2501	2358

All dimensions in mm. Drawings not in scale. Dimensional drawings are for reference only. Actual dimensional drawings are specific to each unit selection. Please contact your JCI representative.

Dimensions and hydraulic connections

All drawings are for two pass evaporator. For other configurations, please, contact JCI.

YVAA-B 599, 0616, 0686, 0699, 0754, 0782, 0824, 0894 and 0921

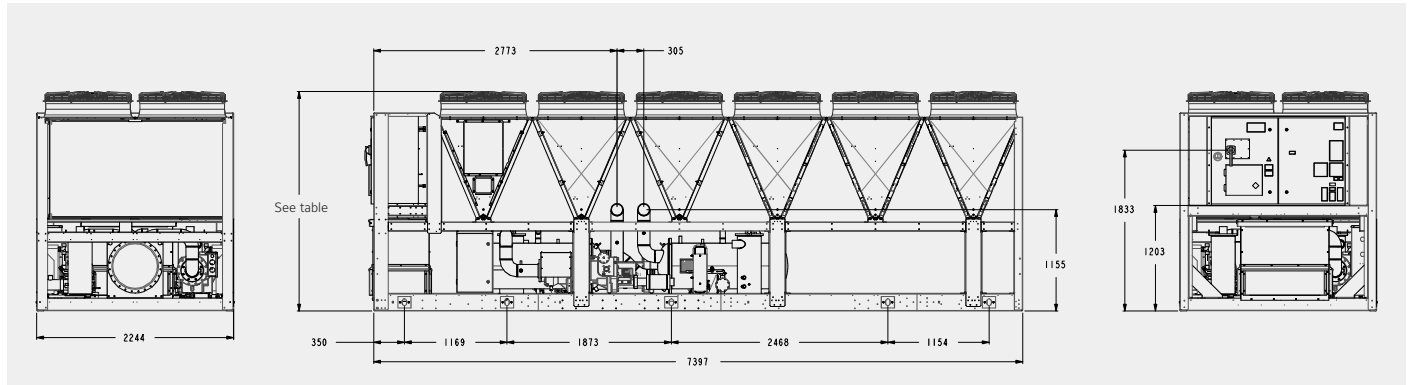

Unit height	EC Fans	Standard fans
YVAA-B 0599, 0616, 0686, 0699, 0754, 0782, 0824, 0894 & 0921	2501	2358

All dimensions in mm. Drawings not in scale. Dimensional drawings are for reference only. Actual dimensional drawings are specific to each unit selection. Please contact your JCI representative.

YVAA-B 0756, 0796, 0919 and 0936

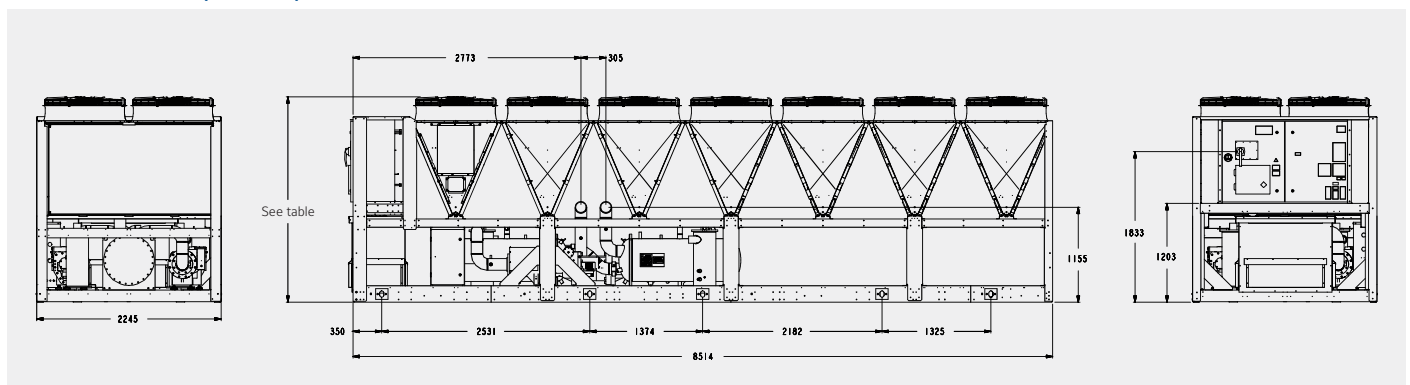

Unit height	EC Fans	Standard fans
YVAA-B 0756, 0796, 0919 & 0936	2501	2358

All dimensions in mm. Drawings not in scale. Dimensional drawings are for reference only. Actual dimensional drawings are specific to each unit selection. Please contact your JCI representative.

Dimensions and hydraulic connections

All drawings are for two pass evaporator. For other configurations, please, contact JCI.

YVAA-B 0769, 0809, 0866, 0924, 0949, 1034 and 1134

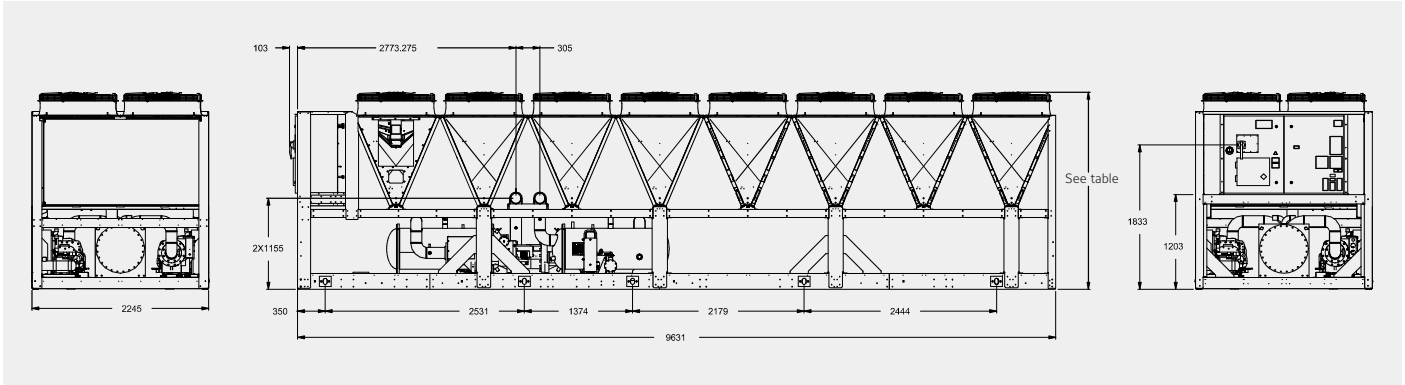

Unit height	EC Fans	Standard fans
YVAA-B 0769, 0809, 0866, 0924, 0949, 1034 & 1134	2501	2358

All dimensions in mm. Drawings not in scale. Dimensional drawings are for reference only. Actual dimensional drawings are specific to each unit selection. Please contact your JCI representative.

YVAA-B 1076 and 1161

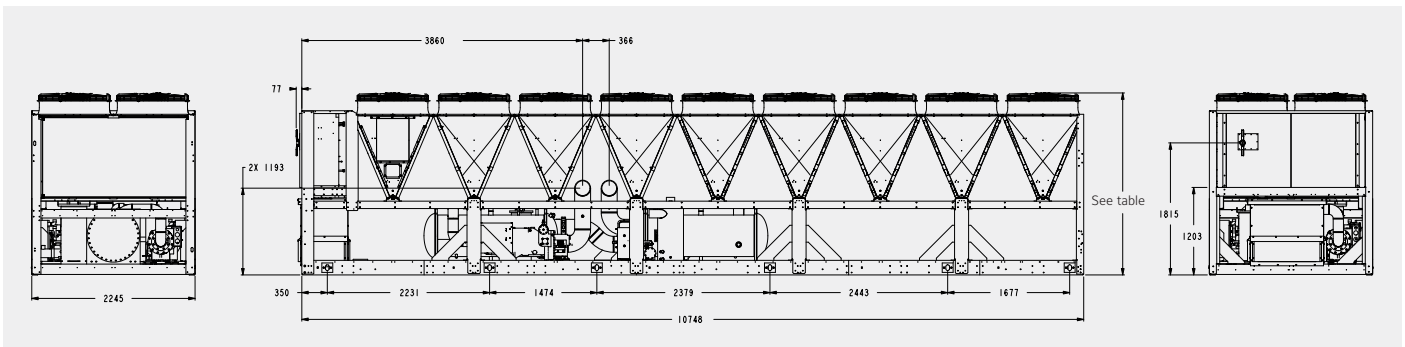

Unit height	EC Fans	Standard fans
YVAA-B 1076 & 1161	2501	2358

All dimensions in mm. Drawings not in scale. Dimensional drawings are for reference only. Actual dimensional drawings are specific to each unit selection. Please contact your JCI representative.

Dimensions and hydraulic connections

All drawings are for two pass evaporator. For other configurations, please, contact JCI.

YVAA-B 1089, 1174, 1271, 1381, 1549 and 1731

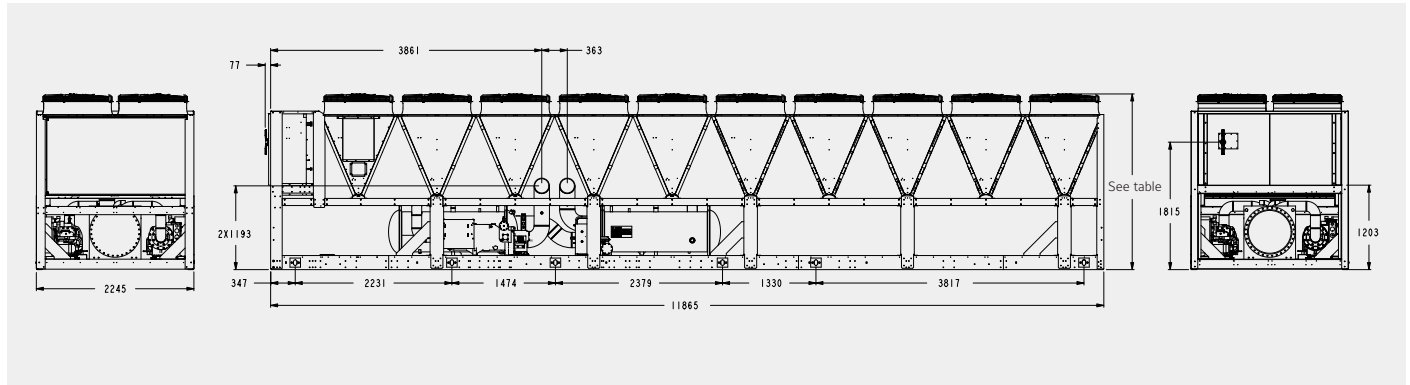

Unit height	EC Fans	Standard fans
YVAA-B 1089, 1174, 1271, 1381, 1549 & 1731	2501	2358

All dimensions in mm. Drawings not in scale. Dimensional drawings are for reference only. Actual dimensional drawings are specific to each unit selection. Please contact your JCI representative.

YVAA-B 1409 and 1606

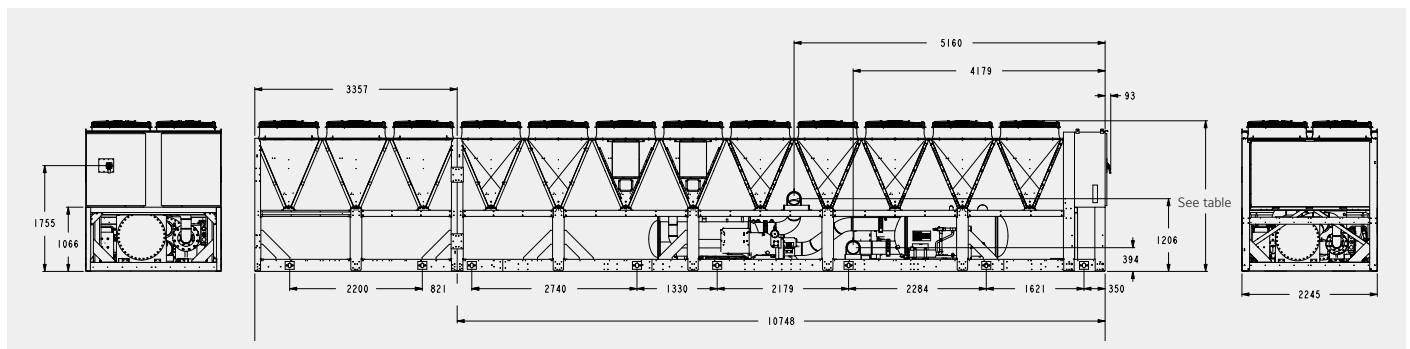

Unit height	EC Fans	Standard fans
YVAA-B 1409 & 1606	2501	2358

All dimensions in mm. Drawings not in scale. Dimensional drawings are for reference only. Actual dimensional drawings are specific to each unit selection. Please contact your JCI representative.

YVAA-B 1649

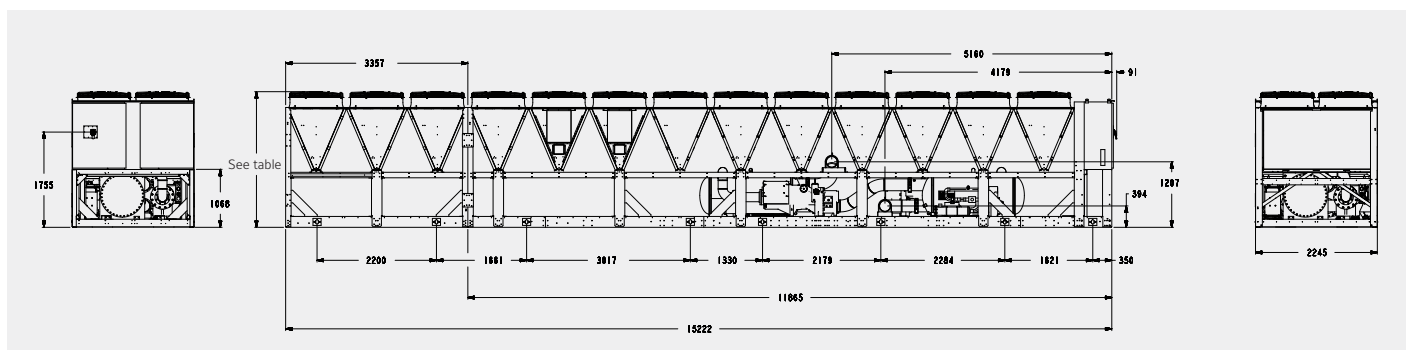

Unit height	EC Fans	Standard fans
YVAA-B 1649	2501	2358

All dimensions in mm. Drawings not in scale. Dimensional drawings are for reference only. Actual dimensional drawings are specific to each unit selection. Please contact your JCI representative.

YVFA

Air-cooled VSD screw chiller with integrated Free-cooling

Cooling capacities from 577 kW to 1664 kW

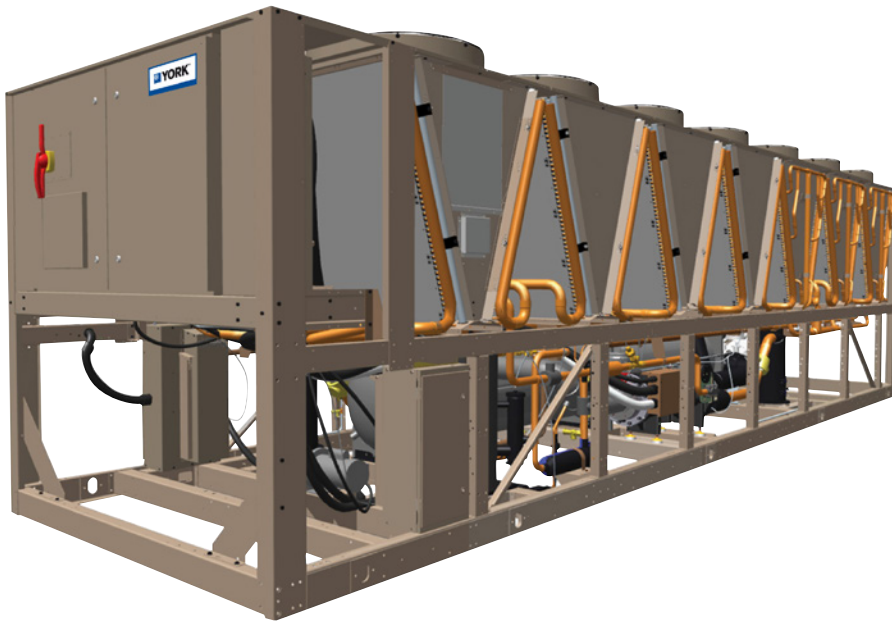

Features

- Available in Open and Closed (glycol free) loop configurations.
- Optimized Annual Energy Savings thanks to the unique combination of the YORK Variable Speed Drive technology expertise and the sophisticated free-cooling controls.
- Reduced installation footprint, thanks to the integration of the free-cooling coils together with the chiller.
- Lower ambient operating range when in free-cooling mode, compared to standard units.

Options/Accessories

- Refrigerant R134a
- BMS Interfacing options
- Advanced Controls (Silent night, quick restart)
- Low temperature application options
- Dual pressure relief valves
- Flow switch
- Epoxy treatment Microchannel Coils
- Fan options
- Enclosure options
- Sound attenuation options
- Anti-vibration mounts options
- Desuperheater

YVFA free-cooling chillers are available in open- or closed-loop configurations to maximize efficiency for your specific type of building

Open-loop configuration

Open-loop design permits building glycol to flow through the free cooling coils directly, with the best performance and the lowest first cost.

Closed-loop configuration

Closed-loop design integrates a brazed plate heat exchanger and pump loop. The building water loop is isolated from the free cooling coils, and the YVFA pump circulates glycol between the brazed plate heat exchanger and the free cooling coils. This provides the lowest pump pressure drop and a building loop that's glycol-free.

Air-cooled VSD screw chiller with integrated Free-cooling

YVFA



Saving energy is simple in every situation

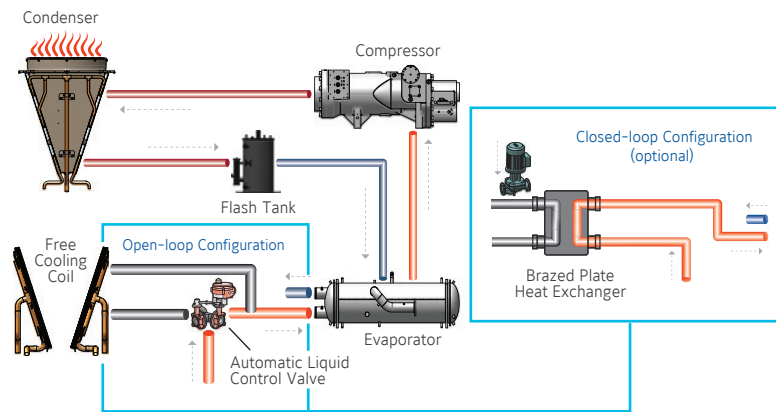

1 Mechanical Cooling Mode

When it's too warm to use ambient air for cooling, the YVFA performs as a standard chiller. The automatic flow-control valve in the open-loop configuration bypasses the free-cooling coils to reduce pump energy. When either cooling load or ambient temperature are less than full design condition, the variable-speed screw compressors and condenser fans modulate to optimize energy use. In a closed-loop configuration, the free-cooling coils are also bypassed.

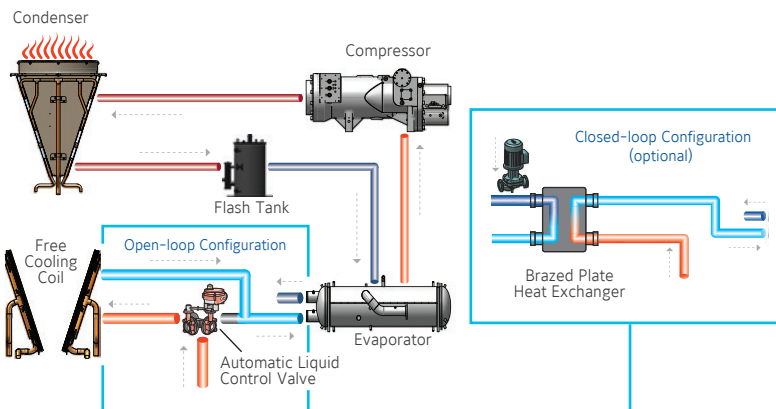

2 Hybrid Cooling Mode

When ambient temperatures permit, liquid flow through the free-cooling coils is enabled. This pre-cooling reduces energy use while the compressors deliver final cooling to meet setpoint. Thanks to YORK VSD Screw technology, at reduced ambient the compressors may draw less power than the fan motors required to move air through the free-cooling coils. Advanced controls provide the most efficient operation rather than simply shutting off compressors as quickly as possible. The Annual Energy Cost Report demonstrates the benefit of this intelligent control.

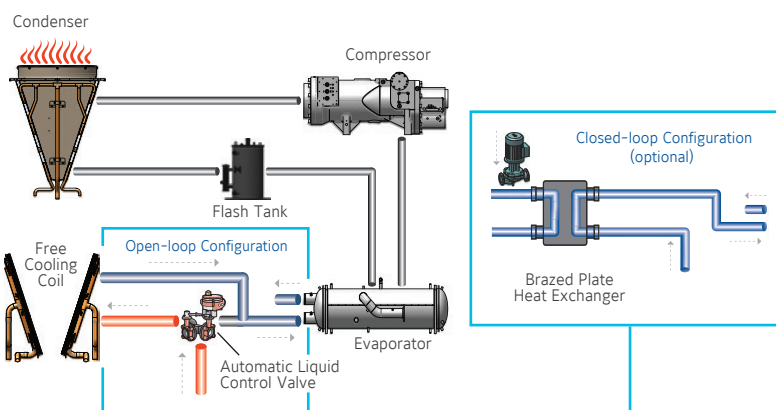

3 Free Cooling Mode

At lower ambient temperatures, full cooling load can be most efficiently delivered by the free-cooling coils. Compressors are shut off and the VSD fans are modulated to meet the cooling setpoint.



Manufacturer reserves the rights to change specifications without prior notice.

Dimensions and hydraulic connections

Open-loop (OL) configuration models

YVFA 0539 OL

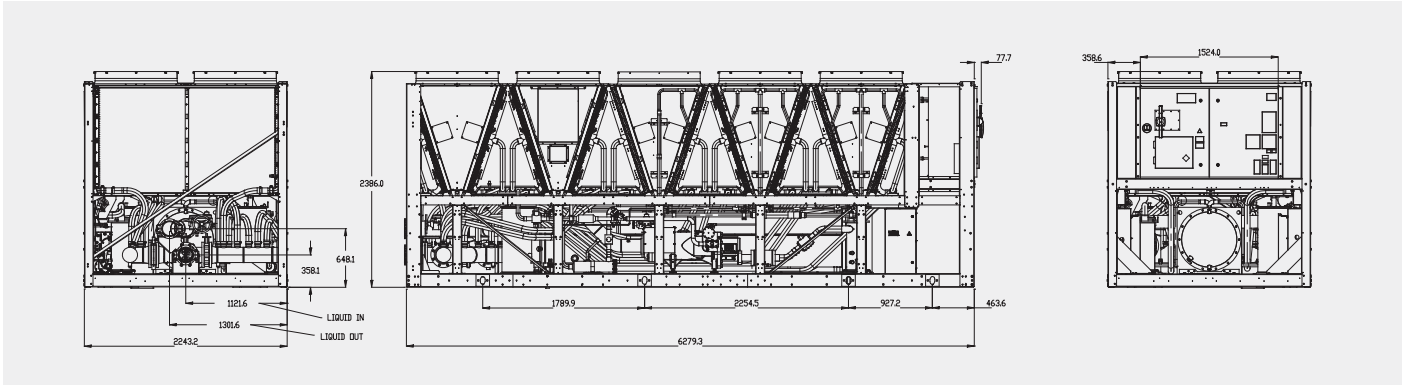

All dimensions in mm. Drawings not in scale.

YVFA 0709 OL

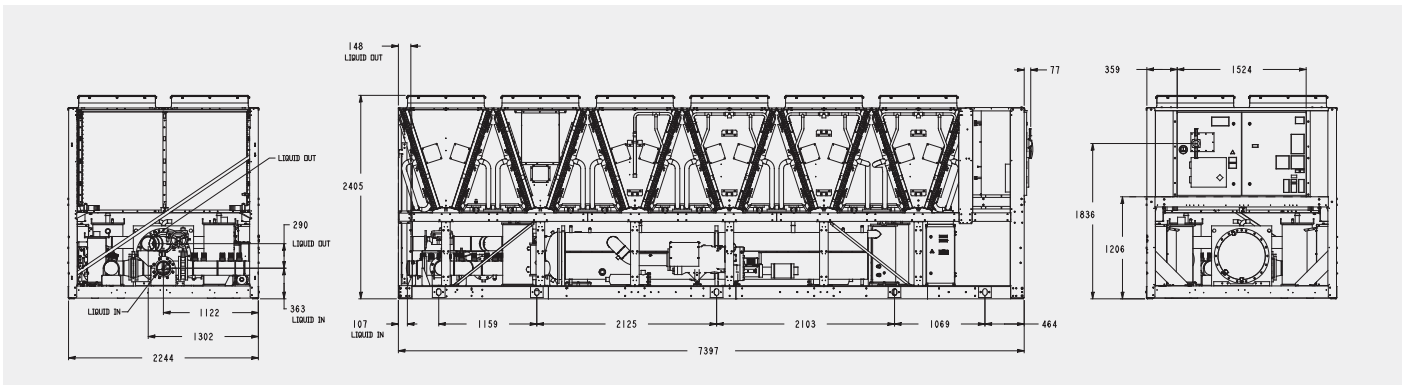

All dimensions in mm. Drawings not in scale.

YVFA 0889 OL

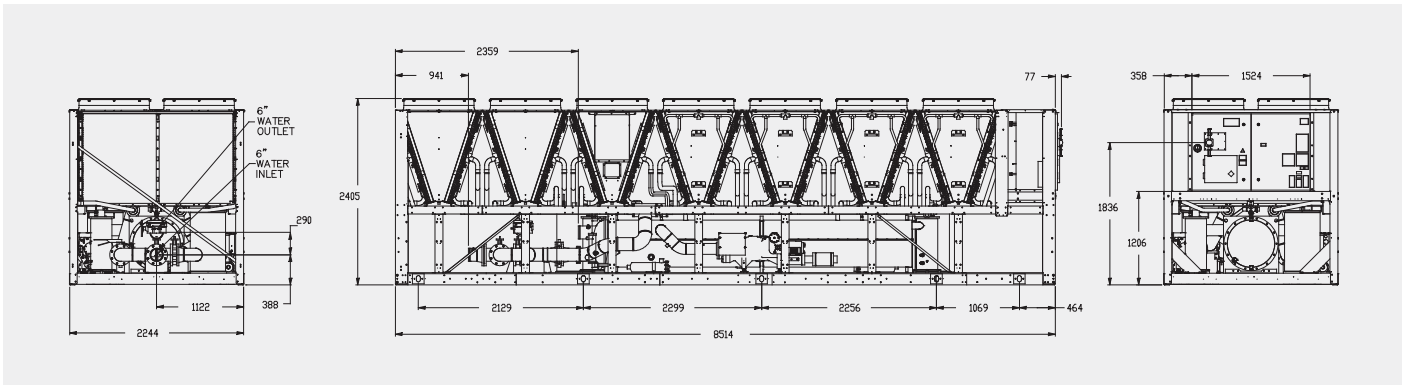

All dimensions in mm. Drawings not in scale.

YVFA 1009 OL

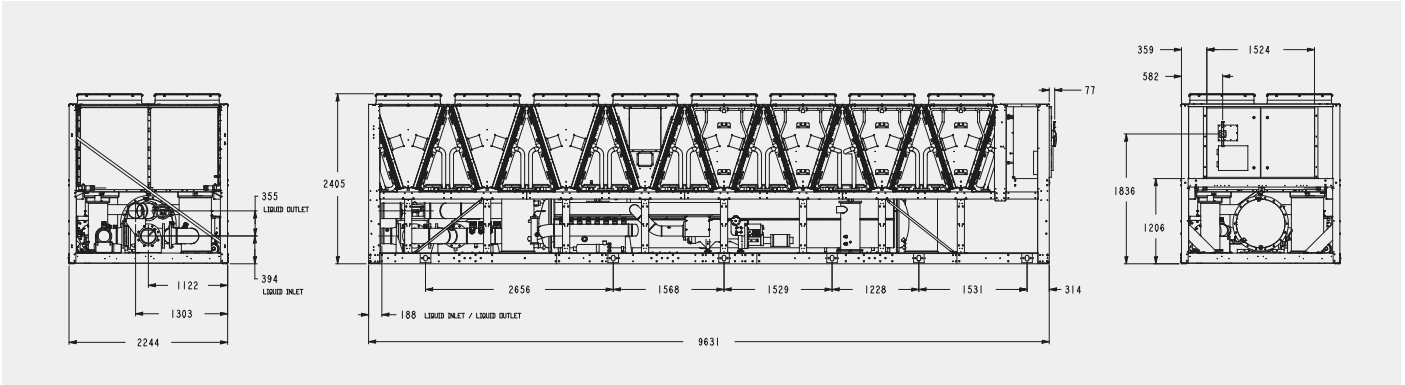

All dimensions in mm. Drawings not in scale.

YVFA 1069 OL

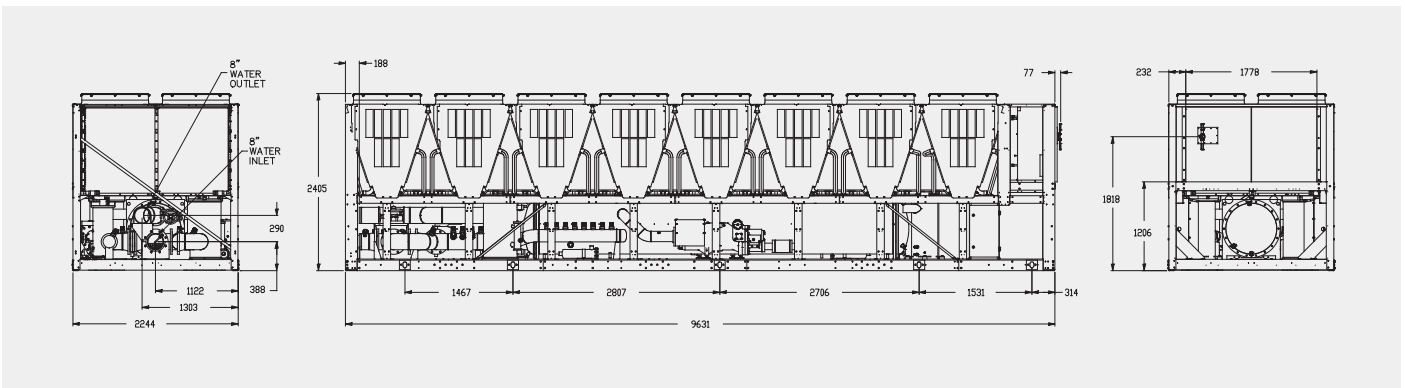

All dimensions in mm. Drawings not in scale.

YVFA 1239 OL

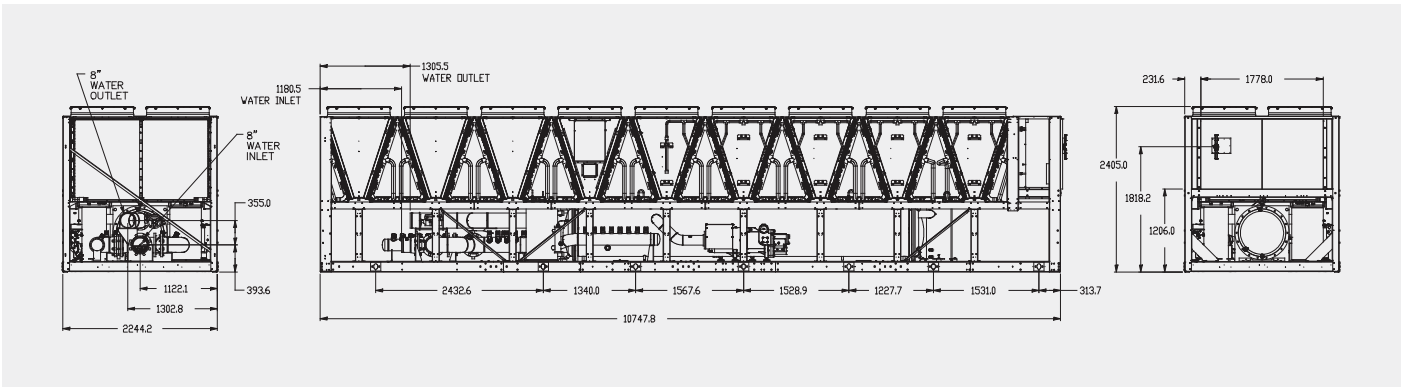

All dimensions in mm. Drawings not in scale.

YVFA 1419 and 1589 OL

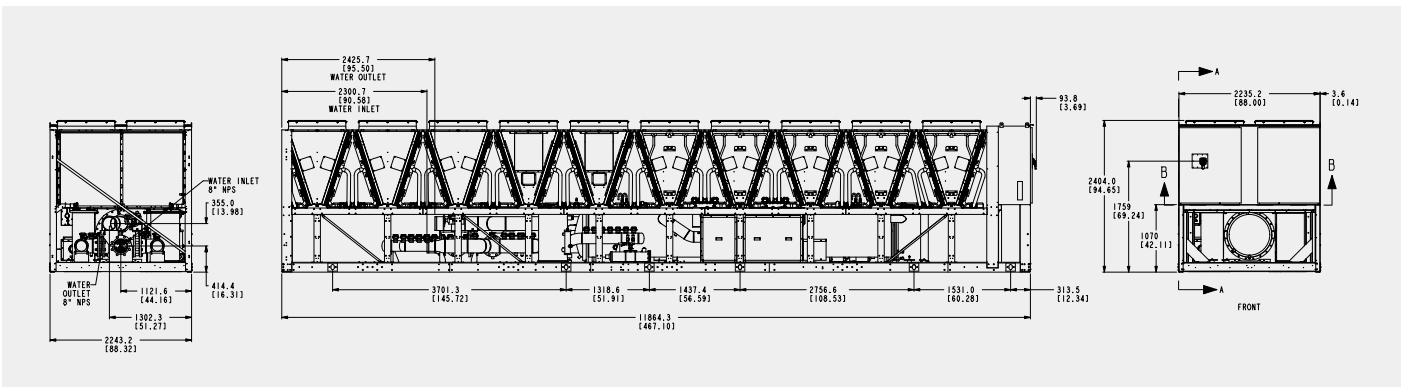

All dimensions in mm. Drawings not in scale.

Dimensions and hydraulic connections

Closed-loop (CL) configuration models

YVFA 0709 CL

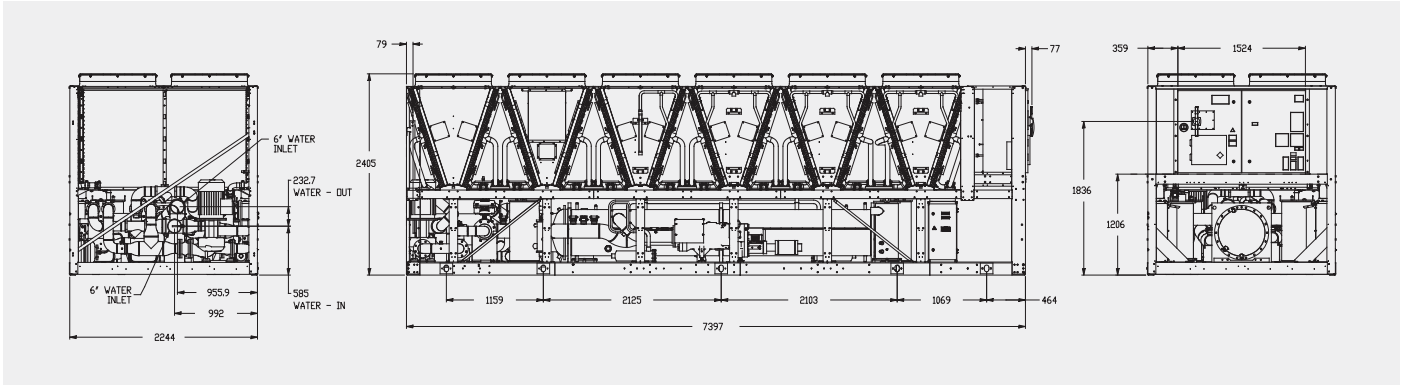

All dimensions in mm. Drawings not in scale.

YVFA 0889 CL

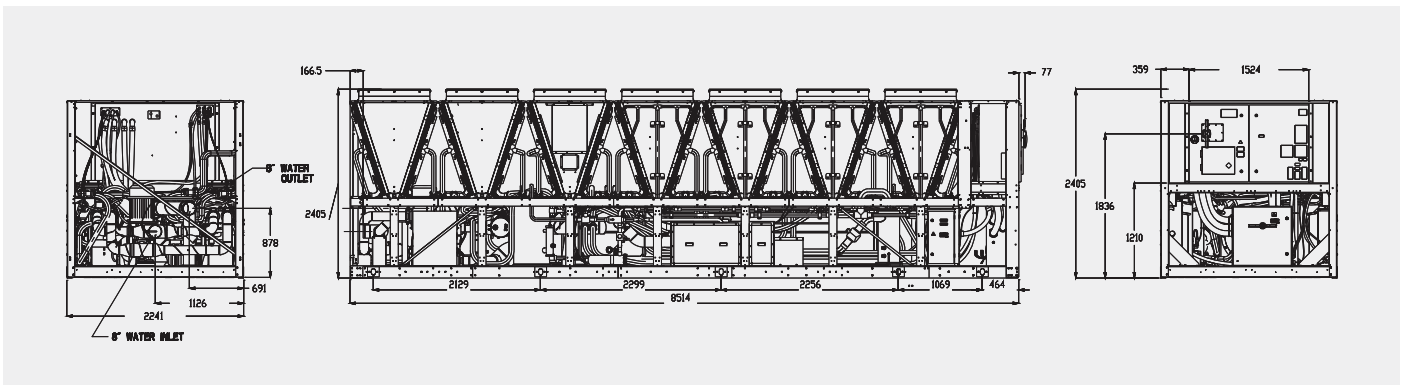

All dimensions in mm. Drawings not in scale.

YVFA 1069 CL

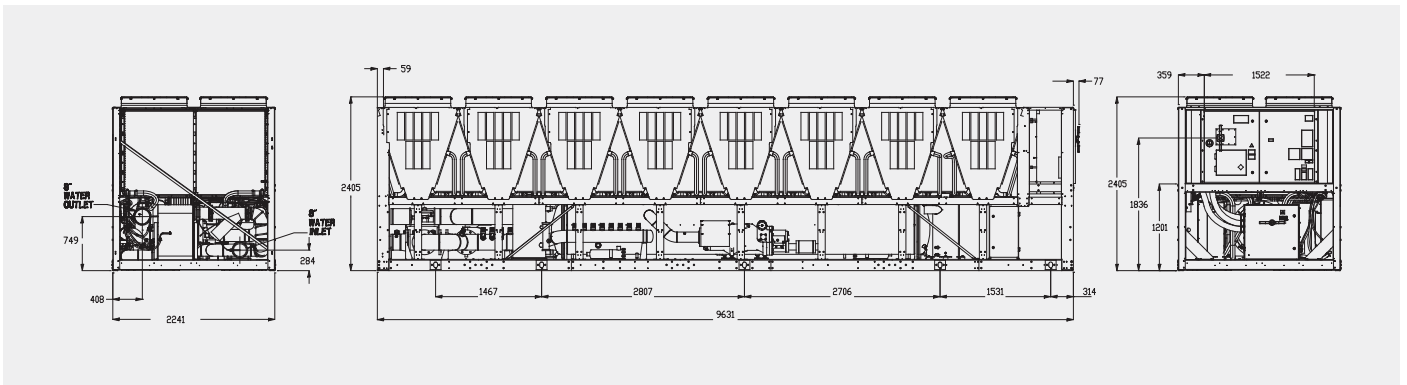

All dimensions in mm. Drawings not in scale.

Dimensions and hydraulic connections

Closed-loop (CL) configuration models

YVFA 1239 CL

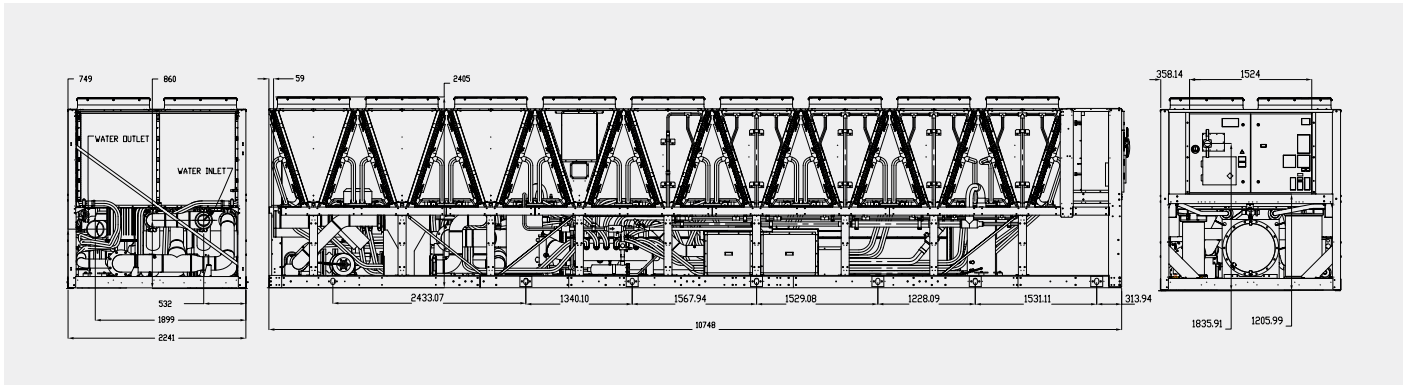

All dimensions in mm. Drawings not in scale.

Application flexibility (*) example of selections

YVFA	0539	0709	0889	1009	1069	1239	1419	1589
Mechanical Cooling capacity (kW)	577	684	898	1034	1158	1232	1517	1664
Full Load Efficiency (EER) - Mechanical	2.8	2.78	2.78	2.88	2.73	2.77	2.46	2.32
Part Load Efficiency (SEPR) - Mechanical	6.02	5.98	6.06	6.24	5.59	5.5	5.54	5.5
Sound power level (dBA) - Mechanical	103	104	106	106	106	107	107	109
Total Temperature Free-Cooling (°C)	-0.5	-0.4	-1.5	-1.5	-2.7	-2.1	-3.3	-4.5

Cooling Capacity for Open-Loop configuration at: entering/leaving chilled fluid temperature 16°C/10°C (30% Ethylene Glycol), ambient temperature 35°C.
Sound Pressure according to Eurovent conditions.

(*) YVFA is a tailor and tune chiller. Its performance will be factory-adjusted to match the exact site requirements based on the specific project operating conditions. The table above shows only a representative sample of performance points based on generic project operating conditions working with R513a refrigerant. For R134a information contact your JCI Representative.

For tailored and tuned performance based on your specific project requirements, and for more information, please contact your Johnson Controls representative. The above data is based on Johnson Controls' selection software Selection Navigator SN24.12. Please refer to the latest version of the software for specific projects.

Technical data

YVFA			0539	0709	0889	1009	1069	1239	1419	1589
Dimensions	Length	mm	6280	7397	8514	9631	9631	10748	11864	
	Width	mm	2242						2243	
	Height	mm	2405						2404	
Operating weight kg			7394	8504	10396	11842	11884	12900	14131	17140
Refrigerant charge kg			172	164	216	246	262	282	365	368



YVAM

Air-cooled magnetic bearing centrifugal chiller

Cooling capacities from 1400 kW to 1800 kW



Options/Accessories

- R-1234ze ultra-low GWP refrigerant standard
- Leaving fluid temperatures up to 30°C
- BMS Interfacing options
- Advanced Controls (Silent Night, Quick Restart)
- Low ambient capable to -29°C
- Dual pressure relief valves
- High efficiency EC fans standard
- Enclosure options
- Sound treatment standard full load sound power as low as 97 dBA
- Anti-vibration mounts options

Optimized for uptime, efficiency and a lower total cost of ownership, YORK® YVAM Air-Cooled Magnetic Bearing Centrifugal Chillers from Johnson Controls leverage pioneering magnetic bearing technology for reliable, real-world performance in hyperscale and colocation data centers.

Higher Efficiency

Full Load Input Power can be over 25% lower than air-cooled screw chillers. For a 40MW data center, this reduces the size of the electrical infrastructure and allows 2MW to be reallocated from mechanical to compute.

Simplified Design

Next generation off-design efficiency meets annualized PUE targets without free cooling coils which add weight, complexity, pressure drop, and embodied carbon. This means customers can use water instead of glycol, which complicates environmental regulations, containment, and disposal processes.

Unbelievably Quiet

The magnetic bearing driveline virtually eliminates noise and vibration that comes from traditional air-cooled chiller drivelines. The YVAM produces notably less sound, with full-load sound of just 65 dBA at a distance of 10 meters.

Inhouse Components

The YVAM uses a state of the art driveline that was designed inhouse, by YORK, and developed specifically for submersible US Navy vessels. The magnetic bearing centrifugal compressor and variable speed drive are individual unit assemblies that allow for independent inspection, service, repair, and replacement which improves uptime and lowers maintenance spend.

Futureproof

The YVAM can operate with chilled fluid temperatures as low as 18 °C for air-cooled serves. The same hardware can also produce 32 °C chilled fluid for liquid-cooled servers. This means the same equipment can be used as server architecture changes which increases the useful life of the product.

Air-cooled magnetic bearing centrifugal chiller

YVAM 1400 to 1800 kW



Designed for critical applications

It's essential to maximize chiller uptime for mission-critical, temperature sensitive applications. Data centers and high-value connected loads face a constant threat of violating service level agreements, equipment failures and lost production, all of which cost money. Owners and operators must have confidence in the equipment serving their processes.



Reduce risk of cooling disruption

Quick Start saves both time and money by:

- Reducing time for chiller restart after a power failure
- Rapidly bringing the chiller back to pre-power failure operating capacity
- Maintaining temperature of critical spaces and equipment
- Lowering the risk of damage to temperature-sensitive equipment

Since uptime is vital, Quick Start is included as standard on all YORK® YVAM magnetic bearing centrifugal chillers.



Smarter power management

YVAM chillers include an integral emergency power management system, which ensures critical systems remain energized through a power outage. During a power failure, the magnetic bearing controller, Optiview Panel and OptiSpeed variable-speed drive control circuits remain energized until an emergency generator is activated. This eliminates the need for a control panel reboot, so the chiller is able to restart the moment power is restored and compressor coastdown is complete.



Variable Speed Drive

- Standard product meets IEEE-519 requirements
- Active front end ensures TDD is kept below 5%
- Displacement power factor 0.97 or better
- Delivers highest part load efficiency for real-world energy savings at off-design conditions
- Near-zero in-rush increases motor life
- Liquid cooled to reduce maintenance costs

Modernized Controls

- Full screen display and graphics
- Panel keeps record of shutdowns in memory
- Remote control through BAS:
 - BACnet
 - ModBus
 - N2
 - LON
- Continuous system monitoring
- Trending data with ability to customize points



Manufacturer reserves the rights to change specifications without prior notice.



YAS

Air-Cooled Chillers and Heat Pumps with R290 (Propane)

Research and innovations for sustainable efficiency

Customer satisfaction and the improvement of our customers' working conditions are top priorities for Johnson Controls.

We know that new market requirements in terms of environmental protection can present a challenge for our customers. That is why we continue to invest in innovative and environmentally friendly solutions for refrigeration and air conditioning so that you can achieve your sustainability goals.

The environmentally conscious use of our limited resources is already taken into account in the development and manufacture of all of our products. A major focus in research and product development is on HVAC systems that are low-noise, energy-saving and also use environmentally friendly refrigerants.

Propane can be used in many areas - either pure or mixed with other hydrocarbon gases. It is mainly used as a fuel (LPG) or refrigerant (R290). The mixture has been used in industry for decades and, thanks to its non-toxic properties, also in medicine. Propane is also not very harmful to the environment.

Johnson Controls is constantly working on innovations in order to achieve technological progress in the efficient use of natural gas - always in compliance with European guidelines and quality standards. Thanks to our research and environmentally-oriented mindset, all the conditions are in place to continue to be a leader in the market.



Ecodesign Directive ERP 2021

The new generation of propane chillers fulfills the strict ecodesign guideline ERP 2021. The European regulation 2016/2281 prescribes a minimum efficiency for cooling capacities <400 kW for water-cooled devices of 5.20 and for air-cooled devices of 4.10.

Low noise

With a sound-insulated housing for the compressors and Axitop fans, a low sound pressure is achieved. The insulation consists of soundproof standard material (20 mm thick) or thicker material (30 mm thick) according to the required noise emissions. This means that the device can also be installed where there are very strict requirements for sound insulation.

Energy saving

Reducing investments and operating costs, environmental compatibility and optimizing energy consumption are essential factors when selecting new devices. The efficient functioning of the propane chiller can save high operating costs.

Simple controls

The microprocessor controls and manages time control, speed and safety. The overheating is regulated by means of PID control by the electronic expansion valve, whereby the operation of the system and consumption are optimized. The microprocessor detects irregularities through an automatic diagnosis and enables remote monitoring of the system. An internal memory records the operating status at the time of an alarm so that it can be shown on the display.

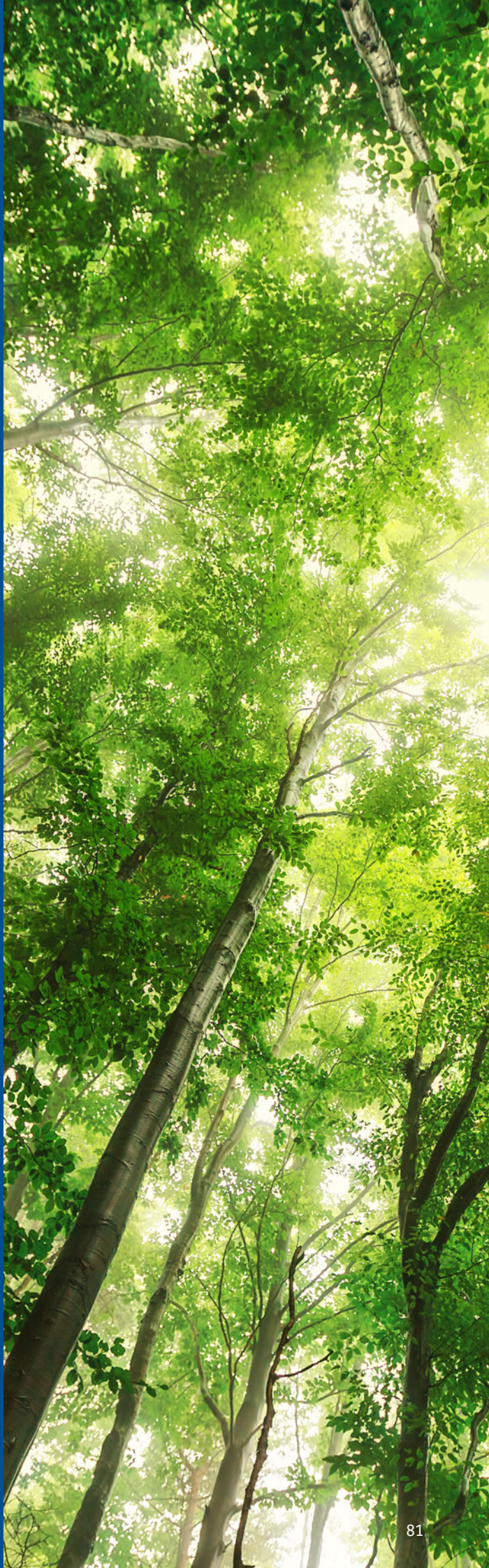

Application limits under different environmental conditions

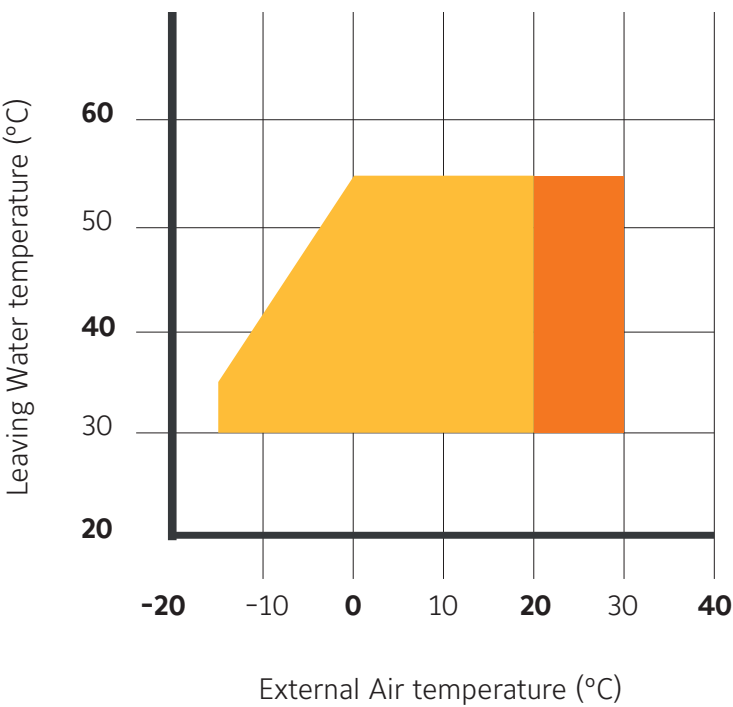
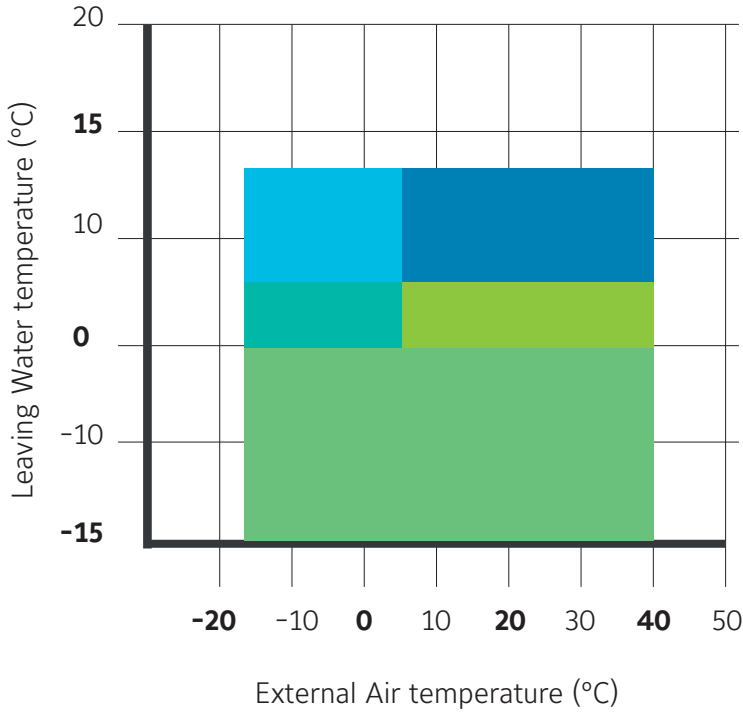

Note: Operating charts are for reference only. Actual operating maps are specific to each unit selection. Please contact your JCI representative.

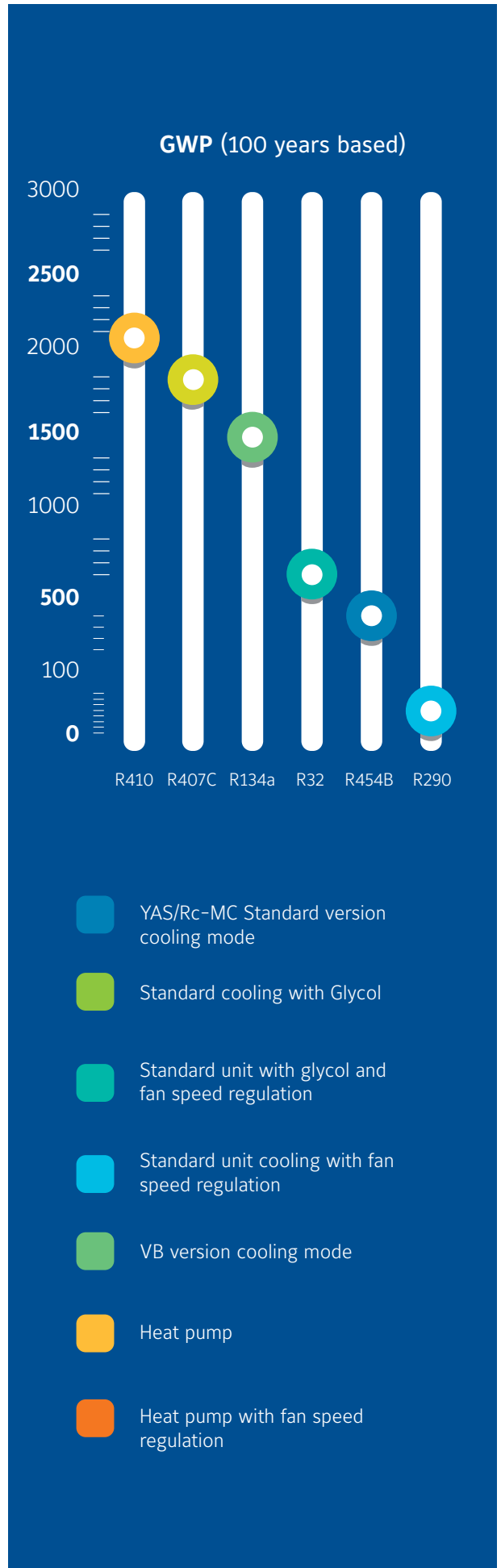

- YAS/Rc-MC Standard version cooling mode
- Standard cooling with Glycol
- Standard unit with glycol and fan speed regulation
- Standard unit cooling with fan speed regulation
- VB version cooling mode
- Heat pump
- Heat pump with fan speed regulation



YAS/Rc-MC

Air-cooled chiller with reciprocating compressor, axial fans and R290 refrigerant

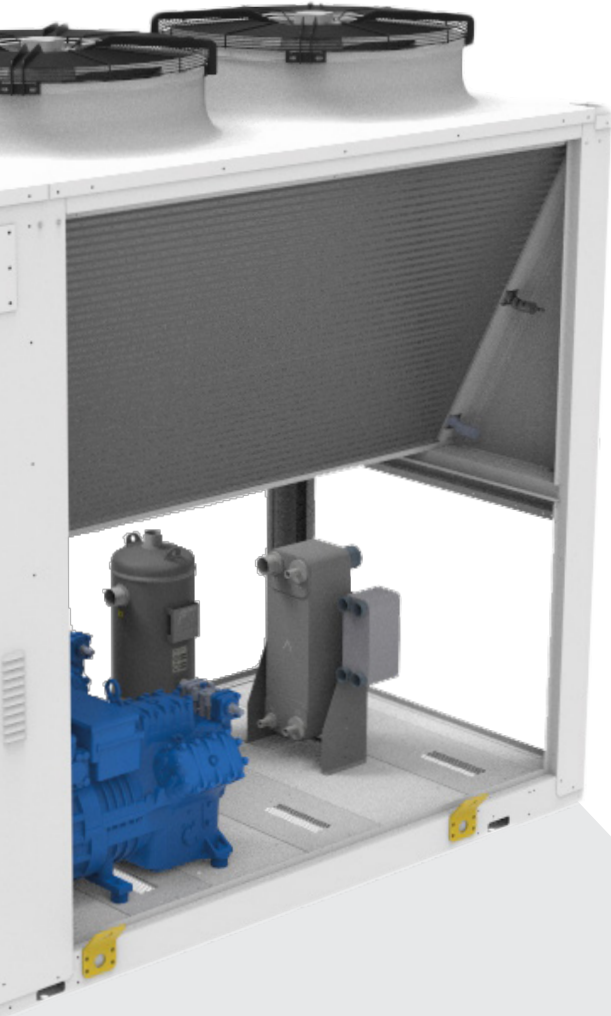

This model is particularly suitable for cooling in industry or in air conditioning in the service sector where excellent performance and very low environmental impact are required. The refrigerant used is propane, a non-toxic hydrocarbon that emits almost no environmentally harmful substances even in high concentrations and has thermodynamic properties that enable a high level of efficiency.

Depending on the cooling capacity, the units are available with one or two independent cooling circuits, which are equipped with one or two compressors for each circuit. Thanks to the many options available, these liquid chillers are particularly versatile and can be easily adapted to different types of plants where chilled water production is required.

All the units are completely factory assembled, tested and supplied with refrigerant non-freezing oil charge; so, once on installation site, they only need to be positioned and connected to the hydraulic and power supply lines.

The Air-cooled chillers meet the requirements of the European regulation 2016/2281.

Operation Limits (standard version):

Air:	from +10 to + 40°C
Water (evaporator outlet):	from -2 to +15°C (standard version)
	from -14 to -2°C (VB-Version)
	from -5 to +15°C (F-Version)

The following versions are available:

YAS-MC: Standard version

YAS-MC-VB: Version suitable to produce low temperature water/glycol mixture, equipped with electronic thermostatic valve, suction gas separator, inverter fans, evaporator higher insulation (20mm thickness)

Main components

Frame

Strong and compact structure, made of base and frame with high-thickness galvanized steel elements assembled with stainless steel rivets. All galvanized steel surfaces externally positioned are superficially coated by an oven powder-painting with colour RAL7035.

The technical section which contains compressors and the other cooling circuit elements, except the condensing part, is closed in a cabinet; if a refrigerant leak occurs the technical vane is automatically airy using an external centrifugal fan which is able to clean all the air inside the cabinet 4 time/minute. To reduce the sound level it is possible to insulate the technical section with a sound and fire proof standard thickness material or higher thickness material (CFU option).

Compressors

Semi hermetic alternative type optimized to operate with the hydrocarbons and realized in compliance with the safety regulation in force. The electrical motor, arranged for starts with low inrush current (PW option), is equipped with thermal protection module (installed in the electrical cabinet); the lubricating system, of forced type, is equipped with oil filters and check valves to survey the lubricating pressure and is made through a high pressure pump. Each compressor is installed on rubber type vibration dampers and is provided with switch-off valve on suction and discharge side, electronic differential pressure switch for the oil level control, crankcase heater and temperature probe on discharge side to control the compressor's discharge temperature. If the compressors are installed in "tandem" version each one is equipped with oil level sensor and oil recuperator; this device activates automatically when in one compressor the lubricant level goes down then minimum value.

Evaporator

Stainless steel plates type mono or bi circuits, thermally insulated using a flexible closed cells mattress of high thickness. Is also provided with a safety differential pressure switch which does not allows the unit operation in case of water flow lack or reduction.

Coils

The external exchanger coils are made of microchannel aluminium extruded pipes and brazed aluminium fins. Thanks to the reduced whole volume and the high external surfaces, the microchannel coils allow a great reduction of refrigerant charge and an high heat exchange capacity.

Fans

6 poles axial fans with electrical motor and external rotor directly coupled to the impeller; aluminium blades with wings profile are suitably designed to avoid any turbulence in the air detachment zone, granting in this way the maximum efficiency with the minimum noise level. The fan is equipped with a galvanized steel protection grid painted after the construction; the fan motors are of totally closed type and have got a protection factor IP54 and winding-flooded protection thermostat.

Cooling circuit

Independent cooling circuits, each provided with a shut-off valve for refrigerant charge, antifreeze probe, sight glass, dehydrating filter for R290 with wide filtering surface, high pressure side safety valve equipped with connector to the discharge refrigerant conveying piping, electronic thermostatic valve (from 2402 size), settable pressure switches and high/low pressure gauges for R290 specifically.

All the units are equipped with a leak sensor which is able to turn off the compressors and turn on the extraction fan in case of a refrigerant leak occurs.

Electrical board

The housing contains all electrical and control components. All components are wired and tested at the factory. The electrical cabinet has got a watertight structure, equipped with cable glands with protection factor of IP65/66.

Besides the electrical cabinet contains all the power and control devices, microprocessor electronic board complete with keyboard and display for visualizing several function available, main switch of lock-door type, isolation transformer for auxiliary circuits, automatic switches, fuses and protection switches for compressors and fans motors, terminals for general alarm and unit remote ON/OFF, spring type terminal board and the possibility to interface to BMS system.

Standard equipment

YAS/Rc-MC VB

YAS/Rc-MC

Power and control housing separate from the compressor

The power and control housing in accordance with EN 60204 is separate from the compressor housing and is therefore designed in such a way that no refrigerant can penetrate in the event of a leak.

Compressor

The unit is equipped with high efficiency semi hermetic alternative compressors suitable for use in a explosion hazard zone (Zone 2) due to the presence of flammable gases following the ATEX 2014/34/UE European norm.

Leak sensor

The leakage sensor consists of an electronic detector and a catalytic sensor that can detect the presence of propane in the air with a sensitivity of 10% of the lower explosive limit (LFL). The sensor is set to two concentration levels (20% and 30% of LFL) which will activate two alarms: an automatic reset at 20% and a manual reset at 30%. If an alarm occurs, all electrical components of the unit with the exception of the leakage sensor and the exhaust fan are de-energized.

Reduced vibrations in the refrigeration circuit

The refrigeration circuits are equipped with vibration dampers on both the suction side and the pressure side of the compressor. The compressors are mounted on rubber dampers to reduce the vibrations transmitted to the frame.

Microchannel coil

The microchannel condensing coil are completely made of aluminium alloy; compared to the standard copper-aluminium ones the microchannel geometry, at the same heat exchange capacity, has less resistance to air flow. This allows to optimize the fan section work reducing consequently both the dimensions (at the same performance) and the electrical consumption. Moreover, this technology allows a great reduction of condensing section weights and also the refrigerant charge.

Extraction fan

The refrigerant extraction fans starts when the gas sensor reveals a gas presence inside of the compressor's cabinet. The fresh air is pushed inside the cabinet allowing the elimination of the mixture air/gas potentially explosive; the fans flow is able to clean completely the air in less than 15 seconds.

Optional equipment

YAS/Rc-MC VB Kp

YAS/Rc-MC Kp

Electronic thermostatic valve

Electronic expansion valve for a perfect overheating regulation in cooling circuits. The design allows a double-flow operation and a perfect hold when the valve is closed.

Inverter compressors

To solve the cooling capacity adaptation the unit can be provided with an external inverter; it guarantees a higher energetic efficiency to the partial loads allowing to reduce the number of starts/stops as well as decrease the sound power.

Inverter pump

Cooled water pump, available as single or double; It can be coupled with an inverter to increase the efficiency and the existing system adaptation.

Hydronic Kit

Pump + buffer tank integrated module composed by: different capacity storage tank (depending on the unit capacity), a circulating centrifugal water pump directly managed by microprocessor which controls the starts and the operation.

Axitop fans

Axial diffuser to combined to condensing section provides a great efficiency and sound pressure improvement. Thanks to his aerodynamic effect minimizes output losses increasing the air flow till 9% to the same electrical consumption or a consumption decrease till 27% to the same air flow; similarly the sound power reduction to the same air flow decrease till.



YAS/Rc-MC

Technical data

Models		521	591	721	871	1001	1402	1702	2102	2402	2902	3402
Nominal cooling capacity	kW	54.2	61.0	74.8	92.9	107.1	155.5	182.8	215.7	252.1	289.7	352.9
Nominal absorbed capacity	kW	16.4	19.2	23.3	29.2	34.1	47.5	56.4	68.2	77.0	96.5	114.1
Nominal absorbed current	A	35.1	38.2	42.5	52.1	63.2	85.5	103.7	126.6	145.5	166.3	205.7
EER	-	3.30	3.19	3.21	3.18	3.15	3.27	3.24	3.16	3.28	3.00	3.09
SEER	-	4.17	4.12	4.24	4.17	4.14	4.15	4.14	4.12	4.26	4.13	4.24
Cooling circuit		1	1	1	1	1	2	2	2	2	2	2
Number of compressors		1	1	1	1	1	2	2	2	4	4	4
Refrigerant charge	kg	4	4	8	8	8	15	15	17	17	16	21

Evaporator: Water temperature IN/OUT: 12°C/7°C												
Water flow	m³/h	9.3	10.5	12.9	16.0	18.4	26.7	31.4	37.1	43.4	49.8	60.7
Pressure drop	kPa	29	35	17	24	31	21	28	26	33	26	36

Axial Fan External air temperature: 35°C												
Quantity		2	2	2	2	2	4	4	4	4	4	4
Air flow	m³/h	17760	17690	20020	40220	40070	80770	80470	80110	79850	794000	119920
Absorbed power	kW	1.2	1.2	1.2	3.9	3.9	7.8	7.8	7.8	7.8	7.8	11.6
Absorbed current	A	5.2	5.2	5.2	7.8	7.8	15.6	15.6	15.6	15.6	15.6	23.4

Weight												
Transport	kg	1094	1096	1206	1304	1310	2002	2098	2156	2522	2598	3100
Operation	kg	1098	1100	1212	1310	1316	2016	2112	2178	2544	2630	3132

Dimensions												
Length	mm	2590	2590	2590	2590	2590	4840	4840	4840	4840	4840	4430
Width	mm	1370	1370	1370	1370	1370	1370	1370	1370	1370	1370	2260
Height	mm	2570	2570	2570	2570	2570	2570	2570	2570	2570	2570	2480

Noise level												
Unit total LWA	dB(A)	86.3	88.1	88.1	92.2	92.2	92.6	95.7	95.7	96.0	96.0	99.2

Power supply												
Tension/Phases/Frequence	V/ph/Hz	400/3/50+N+PE										

YAS/Rc-MC VB

Technical data

Models		521	591	721	871	1001	1402	1702	2102	2402	2902	3402	3702
Nominal cooling capacity	kW	31.8	35.6	43.6	53.5	60.7	87.1	106.1	123.9	149.2	172.0	207.5	235.3
Nominal absorbed capacity	kW	12.4	14.2	14.2	21.1	25.4	34.6	41.9	51.2	57.4	71.7	85.5	103.2
Nominal absorbed current	A	30.2	31.6	31.6	43.3	52.2	58.3	86.3	105.0	122.1	135.5	168.3	204.7
EER	-	2.56	2.52	2.52	2.54	2.39	2.52	2.53	2.42	2.60	2.40	2.43	2.28
SEPR	-	3.58	3.51	3.38	3.70	3.42	3.35	3.75	3.49	3.75	3.38	3.68	3.47
Cooling circuit		1	1	1	1	1	2	2	2	2	2	2	2
Number of compressors		1	1	1	1	1	2	2	2	4	4	4	4
Refrigerant charge	kg	4.0	4.0	7.0	7.0	7.0	14.0	14.0	15.0	16.0	18.0	23.0	24.0

Evaporator: Water + 35% Ethylenglycol Temperature IN/OUT: -3°C/-8°C													
Water flow	m³/h	6.2	7.07	8.6	10.5	11.9	17.1	20.8	24.3	29.3	33.7	40.7	46.1
Pressure drop	kPa	20.4	25.3	12.0	16.9	21.0	13.9	19.4	17.7	24.3	18.6	25.6	31.7

Axial Fan External air temperature: 35°C													
Quantity		2	2	2	2	2	4	4	4	4	4	6	6
Air flow	m³/h	14420	15780	16750	29580	31030	33440	58990	65520	65600	70780	97550	102310
Absorbed power	kW	1.2	1.2	1.2	3.9	3.9	2.4	7.8	7.8	7.8	7.8	11.6	11.6
Absorbed current	A	5.2	5.2	5.2	7.8	7.8	10.5	15.6	15.6	15.6	15.6	23.4	23.4

Weight													
Transport	kg	1052	1056	1164	1242	1246	1942	2096	2162	2518	2600	3102	3120
Operation	kg	1056	1060	1170	1248	1252	1956	2110	2188	2540	2632	3134	3152

Dimensions													
Length	mm	2590	2590	2590	2590	2590	4840	4840	4840	4840	4840	4430	4430
Width	mm	1370	1370	1370	1370	1370	1370	1370	1370	1370	1370	2260	2260
Height	mm	2570	2570	2570	2570	2570	2570	2570	2570	2570	2570	2480	2480

Noise level													
Unit total LWA	dB(A)	86.3	88.1	88.1	92.2	92.2	92.6	95.7	95.7	96.0	96.0	99.2	99.7

Power supply													
Tension/Phases/Frequency	V/ph/Hz	400/3/50+N+PE											

YAS/Rc-MC equipment

Models		521	591	721	871	1001	1402	1702	2102	2402	2902	3402
Amperometer+ Voltmeter	A+V	○	○	○	○	○	○	○	○	○	○	○
Electrical power supply different from standard	AE	★	★	★	★	★	★	★	★	★	★	★
Soundproofed compressors cabinet	CFU	○	○	○	○	○	○	○	○	○	○	○
Compressors inrush counter	CS	○	○	○	○	○	○	○	○	○	○	○
Condensing coil protection grid	GP	○	○	○	○	○	○	○	○	○	○	○
Victaulic insulation on pump side	L1	○	○	○	○	○	○	○	○	○	○	○
Victaulic insulation on buffer tank side	L2	○	○	○	○	○	○	○	○	○	○	○
RS485 Serial interface	IH	○	○	○	○	○	○	○	○	○	○	○
BACnet Serial interface	IH BAC	○	○	○	○	○	○	○	○	○	○	○
SNMP or TCP/ IP Serial interface	IWG	○	○	○	○	○	○	○	○	○	○	○
Phase monitor	MF	○	○	○	○	○	○	○	○	○	○	○
Buffer tank module	MV	○	○	○	○	○	○	○	○	○	○	○
Single pump module	P1	○	○	○	○	○	○	○	○	○	○	○
Higher available pressure single pump	P1H	○	○	○	○	○	○	○	○	○	○	○
Twin pump group	P2	○	○	○	○	○	○	○	○	○	○	○
Higher available pressure double pump module (only one working)	P2H	○	○	○	○	○	○	○	○	○	○	○
Rubber-type vibration dampers	PA	○	○	○	○	○	○	○	○	○	○	○
Spring-type vibration dampers	PM	○	○	○	○	○	○	○	○	○	○	○
Remote display	PQ	○	○	○	○	○	○	○	○	○	○	○
Part-Winding compressors start up system	PW	○	○	○	○	○	○	○	○	○	○	○
Anti-freeze heater on evaporator	RA	○	○	○	○	○	○	○	○	○	○	○
Power factor correction system Cosφ >0,9	RF	○	○	○	○	○	○	○	○	○	○	○
Compressors overload relays	RL	○	○	○	○	○	○	○	○	○	○	○
Microchannel coil	PCP	○	○	○	○	○	○	○	○	○	○	○
Microchannel coil with anticorrosive treatment	ECP	○	○	○	○	○	○	○	○	○	○	○
Personalized frame painting in alternative colour	RV	★	★	★	★	★	★	★	★	★	★	★
External air low temperature operation (-10°C)	BT	○	○	○	○	○	○	○	○	○	○	○
External air low temperature operation (-20°C)	BF	○	○	○	○	○	○	○	○	○	○	○
Partial heat recovery	RP	○	○	○	○	○	○	○	○	○	○	○
EC-Fans	EC	○	○	○	○	○	○	○	○	○	○	○
High pressure double safety valve	HRV2	○	○	○	○	○	○	○	○	○	○	○
Axial fan diffusor	AXT	○	○	○	○	○	○	○	○	○	○	○
Inverter for compressors	VSC	▲	▲	▲	▲	▲	○	○	○	○	○	○
Inverter for pump	VSP	○	○	○	○	○	○	○	○	○	○	○
Electronic thermostatic valve	TE	○	○	○	○	▲	○	○	○	▲	▲	▲

- ▲ Standard
- Optional
- Not available
- ★ Please contact your JCI representative

YAS/Rc-MC VB equipment

Models		521	591	721	871	1001	1402	1702	2102	2402	2902	3402	3702
Amperometer+ Voltmeter	A+V	○	○	○	○	○	○	○	○	○	○	○	○
Electrical power supply different from standard	AE	★	★	★	★	★	★	★	★	★	★	★	★
Soundproofed compressors cabinet with higher thickness material	CFU	○	○	○	○	○	○	○	○	○	○	○	○
Compressors inrush counter	CS	○	○	○	○	○	○	○	○	○	○	○	○
Condensing coil protection grid	GP	○	○	○	○	○	○	○	○	○	○	○	○
Victaulic insulation on pump side	11	○	○	○	○	○	○	○	○	○	○	○	○
Victaulic insulation on buffer tank side	12	○	○	○	○	○	○	○	○	○	○	○	○
RS485 Serial interface	IH	○	○	○	○	○	○	○	○	○	○	○	○
BACnet Serial interface	IH BAC	○	○	○	○	○	○	○	○	○	○	○	○
SNMP or TCP/ IP Serial interface	IWG	○	○	○	○	○	○	○	○	○	○	○	○
Phase monitor	MF	○	○	○	○	○	○	○	○	○	○	○	○
Buffer tank module	MV	○	○	○	○	○	○	○	○	○	○	○	○
Single pump module	P1	○	○	○	○	○	○	○	○	○	○	○	○
Higher available pressure single pump	P1H	○	○	○	○	○	○	○	○	○	○	○	○
Twin pump group	P2	○	○	○	○	○	○	○	○	○	○	○	○
Higher available pressure double pump module (only one working)	P2H	○	○	○	○	○	○	○	○	○	○	○	○
Rubber-type vibration dampers	PA	○	○	○	○	○	○	○	○	○	○	○	○
Spring-type vibration dampers	PM	○	○	○	○	○	○	○	○	○	○	○	○
Remote display	PQ	○	○	○	○	○	○	○	○	○	○	○	○
Part-Winding compressors start up system	PW	○	○	○	○	○	○	○	○	○	○	○	○
Anti-freeze heater on evaporator	RA	○	○	○	○	○	○	○	○	○	○	○	○
Power factor correction system Cosfi >0,9	RF	○	○	○	○	○	○	○	○	○	○	○	○
Compressors overload relays	RL	○	○	○	○	○	○	○	○	○	○	○	○
Microchannel coil	PCP	○	○	○	○	○	○	○	○	○	○	○	○
Microchannel coil with anticorrosive treatment	ECP	○	○	○	○	○	○	○	○	○	○	○	○
Partial heat recovery	RP	○	○	○	○	○	○	○	○	○	○	○	○
Personalized frame painting in alternative RAL colour	RV	★	★	★	★	★	★	★	★	★	★	★	★
Electronic thermostatic valve	TE	▲	▲	▲	▲	▲	▲	▲	▲	▲	▲	▲	▲
External air low temperature operation (-10°C)	BT	○	○	○	○	○	○	○	○	○	○	○	○
External air low temperature operation (-20°C)	BF	▲	▲	▲	▲	▲	▲	▲	▲	▲	▲	▲	▲
EC-Fans	EC	○	○	○	○	○	○	○	○	○	○	○	○
High pressure double safety valve	HRV2	○	○	○	○	○	○	○	○	○	○	○	○
Axial fan diffusor	AXT	○	○	○	○	○	○	○	○	○	○	○	○
Inverter for compressors	VSC	○	○	○	○	○	○	○	○	○	○	○	○
Inverter for pump	VSP	○	○	○	○	○	○	○	○	○	○	○	○

- ▲ Standard
- Not available
- Optional
- ★ Please contact your JCI representative

YAS/Rc-F

Technical data

Models		521	591	721	871	1001	1402	1702	2102	2402	2902	3402
Nominal cooling capacity	kW	50.9	60.1	73.8	89.1	103.8	146.6	174.9	208.5	222.0	283.3	332.6
Nominal absorbed capacity	kW	18.2	20.2	23.9	30.8	35.3	47.5	59.5	70.2	83.6	96.5	118.5
Nominal absorbed current	A	35.1	37.2	41.8	55.2	65.0	83.4	105.7	127.1	153.5	168.6	206.5
EER	-	2.80	2.98	3.08	2.89	2.94	3.08	2.94	2.97	2.65	2.94	2.81
SEPR	-	5.32	5.33	5.34	5.49	5.47	4.51	5.41	5.34	5.23	5.28	5.24
Cooling circuit		1	1	1	1	1	2	2	2	2	2	2
Number of compressors		1	1	1	1	1	2	2	2	4	4	4
Refrigerant charge	kg	4	6	7	7	11	13	15	19	14	19	24
Evaporator: Water temperature IN/OUT: 12°C/7°C												
Water flow	m³/h	9.7	11.4	14.0	16.9	19.7	27.8	33.2	39.5	42.1	53.7	63.1
Pressure drop	kPa	35.3	47.2	22.4	31.1	40.5	26.1	35.5	33.4	40.5	33.7	44.6
Free-cooling section												
F.C. cooling capacity	kW	31.5	32.8	26.3	63.6	66.2	52.1	103.2	82.6	103.1	112.4	119.2
Fluid flow	mc/h	9.7	11.4	14.0	16.9	19.7	27.8	33.2	39.5	42.1	53.7	63.1
Pressure drop	kPa	20.5	27.2	25.0	41.8	54.1	22.6	68.7	61.0	46.2	64.3	58.0
Axial Fan External air temperature: 35°C												
Quantity		1	1	1	2	2	2	3	3	4	4	4
Air flow	m³/h	24120	22870	22910	46960	43780	45350	67380	67670	100610	95900	89990
Absorbed power	kW	2.5	2.5	2.5	5.0	5.0	5.0	7.4	7.4	9.9	9.9	9.9
Absorbed current	A	5.2	5.2	5.2	10.3	10.3	10.3	15.5	15.5	20.6	20.6	20.6
Weight												
Transport	kg	1066	1102	1131	1451	1517	1739	2180	2220	2703	2874	3100
Operation	kg	1088	1124	1150	1482	1558	1776	2246	2280	2794	2974	3178
Dimensions												
Length	mm	1730	1730	1730	2770	2770	2770	3810	3810	4850	4850	4850
Width	mm	1370	1370	1370	1370	1370	1370	1370	1370	1370	1370	1370
Height	mm	2420	2420	2420	2420	2420	2420	2420	2420	2420	2420	2420
Noise level												
Unit total LWA	dB(A)	88.9	90.1	91.8	94.5	94.5	94.7	94.7	96.7	96.5	97.1	99.2
Power supply												
Tension/Phases/Frequence	V/ph/Hz	400/3/50+N+PE										

YAS-Rc F equipment

Models		521	591	721	871	1001	1402	1702	2102	2402	2902	3402
Amperometer+ Voltmeter	A+V	○	○	○	○	○	○	○	○	○	○	○
Electrical power supply different from standard	AE	★	★	★	★	★	★	★	★	★	★	★
Soundproofed compressors cabinet	CFU	○	○	○	○	○	○	○	○	○	○	○
Compressors inrush counter	CS	○	○	○	○	○	○	○	○	○	○	○
Condensing coil protection grid	GP	○	○	○	○	○	○	○	○	○	○	○
Victaulic insulation on pump side	L1	○	○	○	○	○	○	○	○	○	○	○
Victaulic insulation on buffer tank side	L2	○	○	○	○	○	○	○	○	○	○	○
RS485 Serial interface	IH	○	○	○	○	○	○	○	○	○	○	○
BACnet Serial interface	IH BAC	○	○	○	○	○	○	○	○	○	○	○
SNMP or TCP/ IP Serial interface	IWG	○	○	○	○	○	○	○	○	○	○	○
Phase monitor	MF	○	○	○	○	○	○	○	○	○	○	○
Buffer tank module	MV	○	○	○	○	○	○	○	○	○	○	○
Single pump module	P1	○	○	○	○	○	○	○	○	○	○	○
Higher available pressure single pump	P1H	○	○	○	○	○	○	○	○	○	○	○
Twin pump group	P2	○	○	○	○	○	○	○	○	○	○	○
Higher available pressure double pump module (only one working)	P2H	○	○	○	○	○	○	○	○	○	○	○
Rubber-type vibration dampers	PA	○	○	○	○	○	○	○	○	○	○	○
Spring-type vibration dampers	PM	○	○	○	○	○	○	○	○	○	○	○
Remote display	PQ	○	○	○	○	○	○	○	○	○	○	○
Part-Winding compressors start up system	PW	○	○	○	○	○	○	○	○	○	○	○
Anti-freeze heater on evaporator	RA	○	○	○	○	○	○	○	○	○	○	○
Power factor correction system Cosfi >0,9	RF	○	○	○	○	○	○	○	○	○	○	○
Compressors overload relays	RL	○	○	○	○	○	○	○	○	○	○	○
Partial heat recovery	RP	○	○	○	○	○	○	○	○	○	○	○
Copper-copper coil	RR	○	○	○	○	○	○	○	○	○	○	○
Personalized frame painting in alternative colour	RV	★	★	★	★	★	★	★	★	★	★	★
Electronic thermostatic valve	TE	○	○	○	○	▲	○	○	○	▲	▲	▲
Double layer threatment coil	TDS	○	○	○	○	○	○	○	○	○	○	○
External air low temperature operation (-20°C)	BF	▲	▲	▲	▲	▲	▲	▲	▲	▲	▲	▲
EC-Fans	EC	○	○	○	○	○	○	○	○	○	○	○
High pressure double safety valve	HRV2	○	○	○	○	○	○	○	○	○	○	○
Axial fan diffuser	AXT	■	■	■	■	■	■	■	■	■	■	■
Inverter for compressors	VSC	○	○	○	○	○	○	○	○	○	○	○
Inverter for pump	VSP	○	○	○	○	○	○	○	○	○	○	○

- ▲ Standard
- Optional
- Not available
- ★ Please contact your JCI representative

YAS/Rc-WP

Air-cooled heat pumps with reciprocating compressor, axial fans and R290 refrigerant

The air-cooled heat pumps with reciprocating compressors and axial fans are suitable for installation outdoors. The refrigerant used is propane, which is not harmful to the environment. Propane is also particularly efficient and at the same time retains its optimal thermodynamic properties.

Depending on the required heating capacity, the units are available in mono or multi compressor with 1 or 2 independent cooling circuits. Thanks to the many available options, these heat pumps are particularly versatile and are easily adaptable to the different types of plant, where production of chilled water is required. All the units are completely factory-assembled and tested and supplied with refrigerant and non-freezing oil charge. So, once on site, they only need to be positioned and connected to the hydraulic line and power supply.

Units CE certified in compliance with the European regulation 813/2013 at working condition.

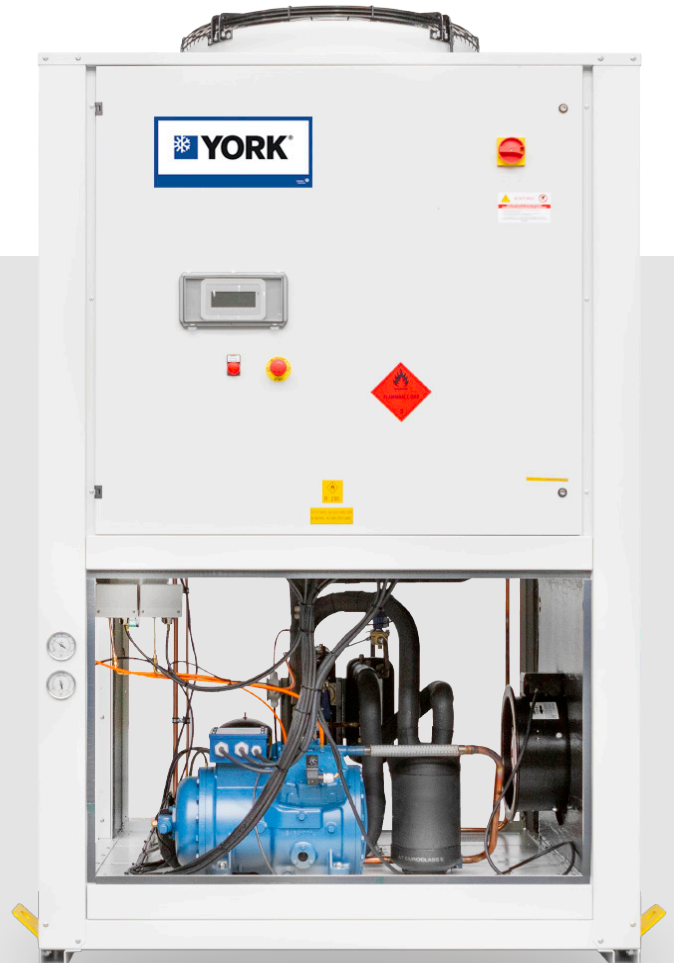

Main components

Frame

Structure strong and compact, made of base and frame with high-thickness galvanised steel elements, assembled with stainless steel rivets. All galvanised steel surfaces externally positioned are superficially coated by an oven powder-painting with colour RAL 7035. The technical section which contains compressors and the other cooling circuits elements, except the condensing part, is hermetically closed from the rest of the ambient, equipped with a leakage sensor and a forced ventilation system. To reduce the sound level, it is possible to insulate the technical section with a sound and fire proof mattress.

Compressors

Semi-hermetic reciprocating compressors optimized to operate with the hydrocarbons and realized in compliance with the regulations on safety in force. The compressors and all the relevant components of the cooling circuit are closed inside a technical compartment which is hermetically closed and kept in constant forced ventilation to avoid air stagnation and refrigerant pockets which can come out from possible leaks. The electrical motor, arranged for starting with low inrush current (option PW), is equipped with thermal protection module (installed inside the electrical cabinet). The lubricating system, of forced type, is equipped with oil filters and check valves to survey the lubricating pressure and is made through a high pressure pump. Each compressor, which works on a single independent circuit, is installed on rubber isolation dampers and provided with anti-vibration dampers and valves on suction and discharge side.

Evaporator

The evaporator is available as a plate heat exchanger made of stainless steel, in a single or double circuit design, insulated and equipped with a differential pressure flow monitor. The external heat exchanger consists of copper tubes in several rows, which have been mechanically expanded inside the aluminum register.

With micro-finned copper tubes and a hydrophilic treatment, positioned in staggered rows and mechanically expanded into an aluminium finned pack. Fins are designed with such a shape providing the highest heat exchange efficiency. The coil is placed directly on a condensate drip tray. The frontal section of the coil can have, as an option, the safety protection grid (Option GP).

Fans

The axial fans with low motor speed are driven directly and controlled by a frequency converter with integrated thermal protection and a 6-pole electric motor, aluminum blades with profile for low-noise and efficient operation. The fan is always equipped with a galvanized touch guard. The motors are completely closed and have an IP54 degree of protection.

Cooling circuits

Each provided with a shut-off valve for refrigerant charge, antifreeze sensor, 4 way valve for circle inversion liquid separator, shut-off valves on liquid line, sight glass, dehydrating filter for R290 with wide filtering surface, high-pressure safety valve on high pressure refrigerant side equipped with a connector to the discharged refrigerant conveying piping, solenoid valve on liquid line with coil, mechanical thermostatic expansion valve, calibrated high and low pressure switches and gauges for R290 specifically. All units are equipped with a special sensor that turning off the compressors in the event of a gas leak.

Electric board

The power and control housing contains all components that are required to regulate and control all motors in the complete unit. This is assembled and tested in the factory. Inside are the power and control elements, a display and keyboard, the main switch and fuses for the motors, the compressors and the fans. It is possible to connect to a BMS system.

YAS/Rc-WP

Technical data

Models		1001	1201	1502	1702	2102	2502	2902	3402
Nominal cooling capacity	kW	90.9	104.3	129.7	148.4	180.6	209.5	248.2	296.8
Nominal absorbed capacity	kW	29.3	35.4	40.0	47.5	58.7	70.9	78.4	96.0
Nominal absorbed current	A	52.0	63.8	74.8	83.6	104.0	128.2	145.5	169.8
EER	-	3.10	2.94	3.24	3.13	3.08	2.96	3.17	3.09
Cooling circuit		1	1	2	2	2	2	2	2
Number of compressors		1	1	2	2	2	2	4	4
Refrigerant charge	kg	13	13	15	20	37	37	46	57
Evaporator: Water									
Water flow	m³/h	15.6	17.9	22.3	25.5	31.1	36.0	42.7	51.1
Pressure drop	kPa	23	29	15	19	27	24	32	26
Axial Fan									
Quantity		2	2	3	3	4	4	5	5
Air flow	m³/h	41700	41700	64710	62580	83400	83400	104250	125250
Absorbed power	kW	3.9	3.9	5.8	5.8	7.8	7.8	9.7	12.4
Absorbed current	A	7.8	7.8	11.7	11.7	15.6	15.6	19.5	25.8
Heat pump working at external air temp. 7°C and water inlet 40/45°C									
Nominal thermal power	kW	103.3	119.5	142.2	168.0	209.3	239.8	280.1	333.8
Nominal absorbed power	kW	29.3	34.4	38.7	46.2	58.8	68.0	76.7	94.2
Nominal absorbed current	A	52.3	62.5	73.6	82.2	104.5	123.9	144.1	168.4
SCOP	-	3.45	3.35	3.30	3.25	3.29	3.29	3.38	3.27
COP	-	3.53	3.48	3.68	3.63	3.56	3.53	3.65	3.54
Weight									
Transport	kg	1416	1466	1798	1876	2246	2366	2918	3106
Operation	kg	1422	1472	1812	1890	2260	2388	2949	3138
Dimensions									
Length	mm	2660	2660	3700	4850	4850	4850	5890	5890
Width	mm	1370	1370	1370	1370	1370	1370	1370	1370
Height	mm	2420	2420	2420	2420	2420	2420	2420	2420
Noise level									
Unit total LWA	dB(A)	93.2	93.2	93.7	93.7	95.2	95.2	95.2	95.5
Power supply									
Tension/Phases/Frequency	V/ph/Hz	400/3/50+N+PE							

YAS/Rc-WP equipment

Models		1001	1201	1502	1702	2102	2502	2902	3402
Amperometer+ Voltmeter	A+V	○	○	○	○	○	○	○	○
Electrical power supply different from standard	AE	★	★	★	★	★	★	★	★
Soundproofed compressors cabinet	CFU	○	○	○	○	○	○	○	○
Compressors inrush counter	CS	○	○	○	○	○	○	○	○
Condensing coil protection grid	GP	○	○	○	○	○	○	○	○
Victaulic insulation on pump side	L1	○	○	○	○	○	○	○	○
Victaulic insulation on buffer tank side	L2	○	○	○	○	○	○	○	○
RS485 Serial interface	IH	○	○	○	○	○	○	○	○
BACnet Serial interface	IH BAC	○	○	○	○	○	○	○	○
SNMP or TCP/ IP Serial interface	IWG	○	○	○	○	○	○	○	○
Phase monitor	MF	○	○	○	○	○	○	○	○
Buffer tank module	MV	■	■	■	■	■	■	■	■
Single pump module	P1	○	○	○	○	○	○	○	○
Higher available pressure single pump	P1H	○	○	○	○	○	○	○	○
Twin pump group	P2	○	○	○	○	○	○	○	○
Higher available pressure double pump module (only one working)	P2H	○	○	○	○	○	○	○	○
Rubber-type vibration dampers	PA	○	○	○	○	○	○	○	○
Spring-type vibration dampers	PM	○	○	○	○	○	○	○	○
Remote display	PQ	○	○	○	○	○	○	○	○
Part-Winding compressors start up system	PW	○	○	○	○	○	○	○	○
Anti-freeze heater on evaporator	RA	○	○	○	○	○	○	○	○
Power factor correction system Cosφ >0,9	RF	○	○	○	○	○	○	○	○
Compressors overload relays	RL	○	○	○	○	○	○	○	○
Microchannel coil	PCP	■	■	■	■	■	■	■	■
Microchannel coil with anticorrosive treatment	ECP	■	■	■	■	■	■	■	■
Partial heat recovery	RP	○	○	○	○	○	○	○	○
Personalized frame painting in alternative colour	RV	★	★	★	★	★	★	★	★
Electronic thermostatic valve	TE	○	○	○	○	○	○	▲	▲
External air low temperature operation (-10°C)	BT	▲	▲	▲	▲	▲	▲	▲	▲
External air low temperature operation (-20°C)	BF	○	○	○	○	○	○	○	○
EC-Fans	EC	○	○	○	○	○	○	○	○
High pressure double safety valve	HRV2	○	○	○	○	○	○	○	○
Axial fan diffusor	AXT	○	○	○	○	○	○	○	○
Inverter for compressors	VSC	○	○	○	○	○	○	○	○
Inverter for pump	VSP	○	○	○	○	○	○	○	○

- ▲ Standard
- Optional
- Not available
- ★ Please contact your JCI representative



Water-Cooled Chillers and Heat Pumps

YORK offers a complete range of water-cooled chiller and heat pumps within **21 kW to 11250 kW capacities**, to cover all customer needs, maintaining the highest efficiency levels and operative performances.

YORK Chillers Units

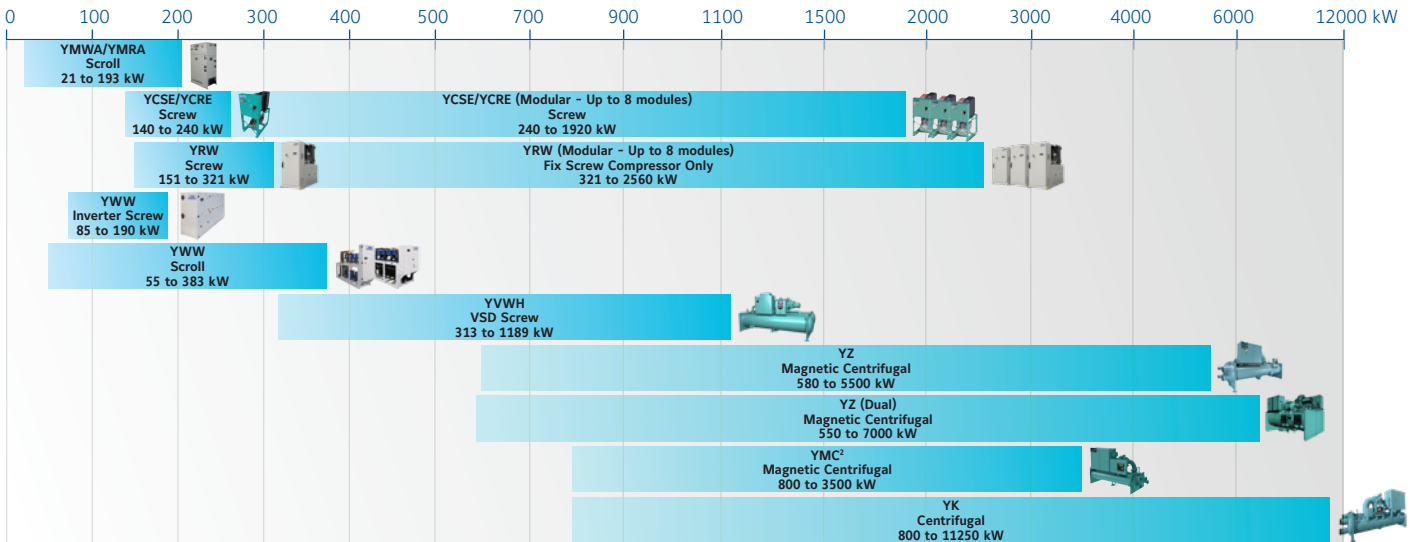

YORK Heat Pump Units

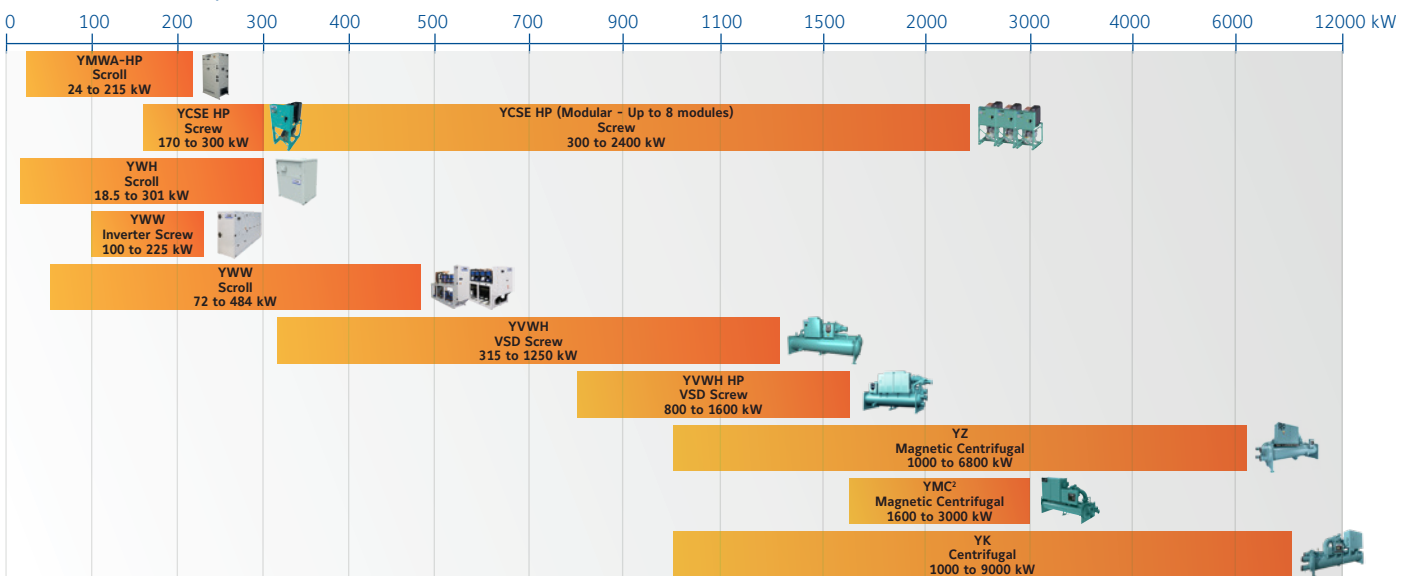

Three different compressor technologies for to meet the most challenging requirements

Scroll compressor

YMWA HP, YWH, YWW

A **scroll compressor** is typically used in small-medium size HVAC applications for residential and commercial buildings. It offers a good compromise between a compact footprint and wide operating envelope. A typical application is a multi-compressor system, often with one inverter compressor for more flexible regulation and improved efficiency.

Screw compressor

YCSE HP, YRW, YWW, YVWH

A **rotary-screw compressor** uses a rotary-type positive-displacement mechanism. Screws are commonly used for medium size comfort or process cooling applications where high compression ratios and lift are required, such as for glycol or dry cooler operation.

Variable compression ratio (Vi) and slide valve can provide the best efficiency while matching the different operating conditions required by each application.

Centrifugal compressor

YZ, YMC², YK

A **centrifugal compressor** adopts a radial design and it is capable of achieving the refrigerant's pressure increase by adding kinetic energy to a continuous flow. Suitable for large refrigerant volumes and cooling capacities, YORK proprietary design is based on a single stage compressor and Inverter VSD to match all the operating conditions by RPM speed. Typically one single impeller is capable of achieving approx. 40°C refrigerant lift. Compared to screws, this type of compressor is less suitable for glycol or dry cooler but provides the highest efficiencies at low lift operation, such as for high setpoint cooling (e.g. Data Centers).

YMWA/YMRA

Water-cooled reversible heat pump with scroll compressor

Cooling capacities from 21 kW to 193 kW
 Heating capacities from 24 kW to 212 kW



Features

- Scroll compressors (single or tandem)
- Higher EER and COP
- 2 different frames/configurations:
 - 1 compressor/1 circuit up to 45 kW
 - 2 compressors/1 circuit from 50 to 190 kW
- Reduced refrigerant charge
- Condensing pressure control
- "Plug and Play" units

Available versions

14 available YMWA sizes in three versions:

- 1) **YMWA-CO**: Cooling only
- 2) **YMRA**: Remote condenser
- 3) **YMWA-HP**: Reversible heat pump

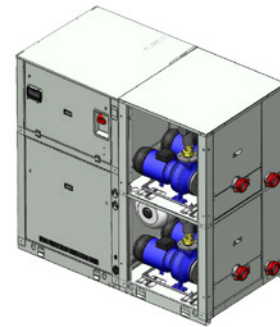

Same cabinet w/o or with factory mounted hydrokit (one or two pumps).
 More compact and slim.

Nominal capacity and technical data

YMWA-CO	0020	0025	0030	0035	0040	0045	0050	0060	0075	0090	0120	0150	0170	0190
Cooling Capacity (kW)	21.2	26.2	31.1	34.8	39.2	46.6	50.9	61.1	77.3	91.1	118.4	147.1	170	192.7
EER	4.58	4.54	4.46	4.53	4.48	4.57	4.29	4.48	4.48	4.38	4.46	4.46	4.5	4.51
SEER	5.58	5.6	5.45	5.50	5.35	5.83	6.13	6.38	5.95	6.61	5.90	6.13	6.08	6.20
ηs, c	220	221	215	217	211	230	242	252	235	261.5	233	242	240	245
Length / Width / Height (mm)	821 / 455 / 1350						1210 / 850 / 1500							
Operating weight (kg)	162	182	179	185	191	214	352	371	392	411	597	666	701	745
YMRA	0020	0025	0030	0035	0040	0045	0050	0060	0075	0090	0120	0150	0170	0190
Cooling Capacity (kW)	21.2	26.2	31.1	34.8	39.2	46.6	50.9	61.1	77.3	91.1	118.4	147.1	170	192.7
Length / Width / Height (mm)	821 / 455 / 1350						1210 / 850 / 1500							
Operating weight (kg)	144	164	166	166	172	172	332	344	365	376	558	612	643	674
YMWA-HP	0020	0025	0030	0035	0040	0045	0050	0060	0075	0090	0120	0150	0170	0190
Cooling Capacity (kW)	20.8	26.0	30.1	34.0	38.1	45.5	49.9	58.9	76.1	88.6	114.9	144.3	165.7	185.4
Heating Capacity (kW)	23.6	28.8	33.7	38.4	43	51.1	58.4	65.6	86.3	102.2	132	164.2	190.1	212.3
EER	4.45	4.47	4.28	4.35	4.33	4.39	4.15	4.24	4.36	4.20	4.26	4.33	4.34	4.28
COP	3.77	3.69	3.59	3.52	3.56	3.6	3.78	3.66	3.92	3.89	3.92	3.95	3.93	3.93
SCOP	5.17	5.45	5.33	5.05	4.83	5.28	5.7	5.88	5.7	5.78	5.75	5.63	5.95	5.63
ηs, h	199	210	205	194	185	203	220	227	220	223	222	217	230	217
Length / Width / Height (mm)	821 / 455 / 1350						1210 / 850 / 1500							
Operating weight (kg)	165	187	184	190	195	219	360	379	403	422	610	683	718	762

Net values at Eurovent nominal conditions:

Cooling mode: Standard Eurovent condition for LCP/W/P/C, 30°C/35°C; 12°C/7°C

Heating mode: Standard Eurovent condition for LCP/W/P/R, 10°C/7°C; 40°C/45°C

SEER and SCOP calculated according to EN14511 and EN14825

ηs calculated according to Ecodesign regulation for chillers comfort cooling and heating (813/2013, 2016/2281).

Ecodesign figures are calculated following variable water flow and variable outlet approach (VW/VO). For other Ecodesign calculations, please contact your JCI representative.

YMRA: Evaporator EWT/LWT 12°C/7°C, condensing temperature 40°C

Dimensions and hydraulic connections

YMWA-CO/HP 0020-0045

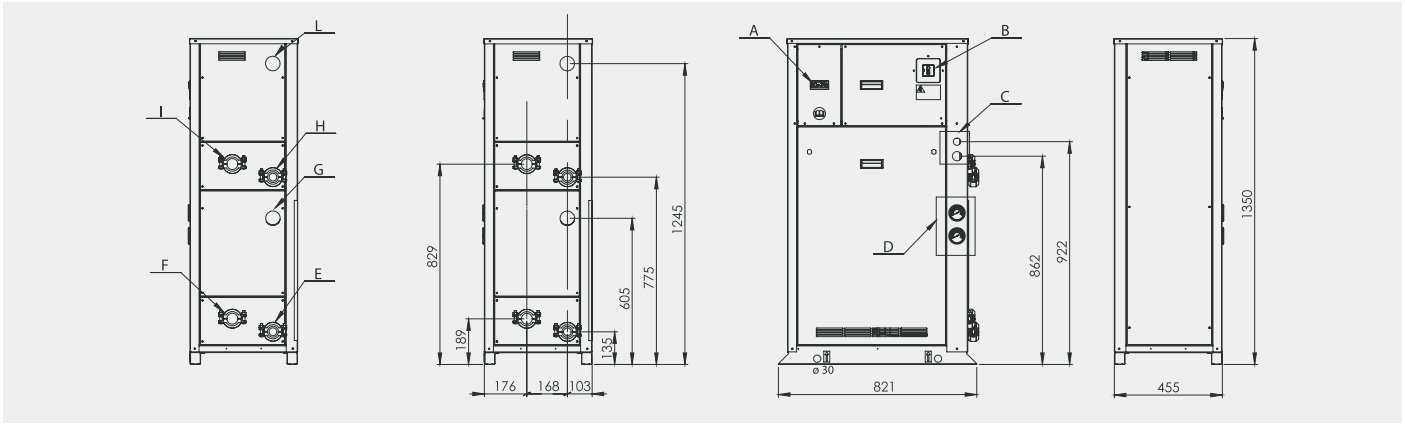

A	Control display	D	Gauge kit
B	Main switch	E, F, G	Water evaporator connections \varnothing 1 1/2" victaulic
C	Auxiliary lines, electrical connection	H, I, L	Water condenser connections \varnothing 1 1/2" victaulic

YMRA Sizes	In	Out
020	H \varnothing 5/8"	L \varnothing 5/8"
025-045	H \varnothing 5/8"	L \varnothing 7/8"

All dimensions in mm. Drawings not in scale.

YMWA-CO/HP 0050-0190 without Hydrokit

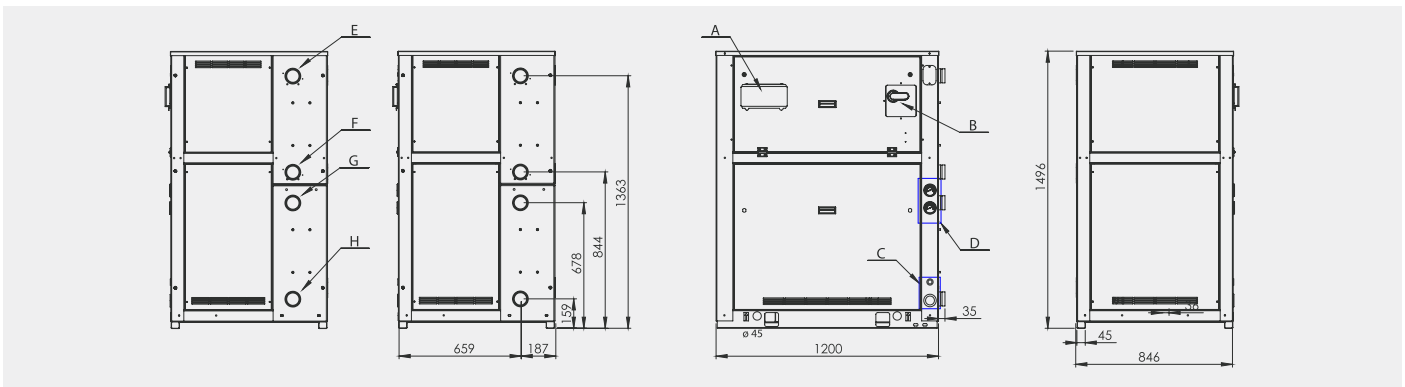

A	Control display	D	Gauge kit
B	Main switch	G, H	Water evaporator connections \varnothing 1 1/2" victaulic
C	Auxiliary lines, electrical connection	E, F	Water condenser connections \varnothing 1 1/2" victaulic

All dimensions in mm. Drawings not in scale.

YMWA-CO/HP 0050-0190 with Hydrokit

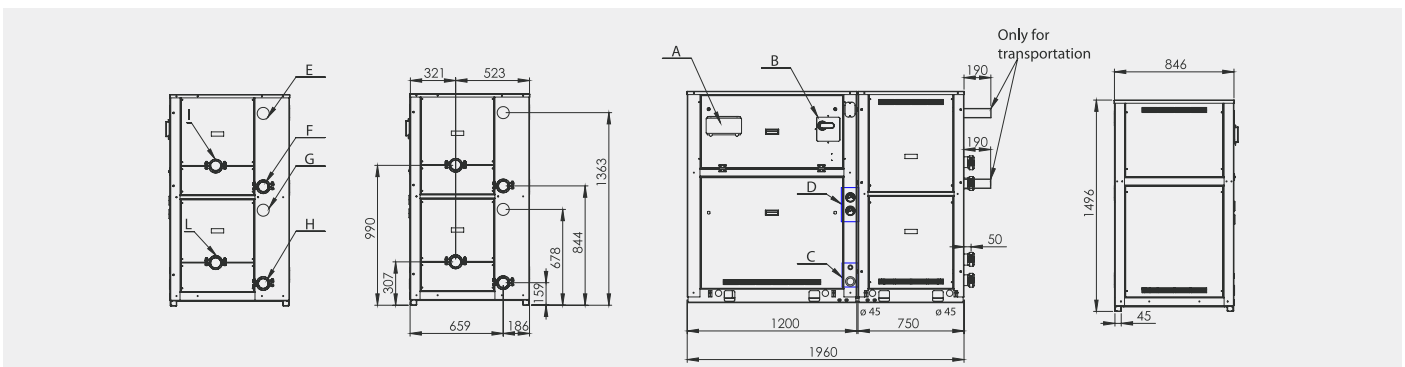

A	Control display	D	Gauge kit
B	Main switch	G, H, L	Water evaporator connections \varnothing 1 1/2" victaulic
C	Auxiliary lines, electrical connection	E, F, I	Water condenser connections \varnothing 1 1/2" victaulic

YMRA Sizes	In	Out
050-060	F \varnothing 5/8"	E \varnothing 7/8"
075-090	F \varnothing 7/8"	E \varnothing 1 1/8"
120	F \varnothing 7/8"	E \varnothing 1 3/8"
150	F \varnothing 7/8"	E \varnothing 1 5/8"
170-190	F \varnothing 1 1/8"	E \varnothing 1 5/8"

All dimensions in mm. Drawings not in scale.



Manufacturer reserves the rights to change specifications without prior notice.

YRW

Water-cooled screw compressor chiller

Cooling capacities from 143 kW to 306 kW



Available as option



Features

YORK® **YRW** water-cooled screw chiller series provide chilled water for all air conditioning applications thanks to the combination of high efficiency in process and comfort cooling applications (Ecodesign Tier II compliant).

The **YRW** can utilize variable speed drive technology to achieve premium efficiency.

The **YRW** helps to reduce CO₂ total emissions using low GWP refrigerant **R513A**.

Options

- Inverted VSD compressor option, up to 5% improved SEER performance
- Modular configurations available, with n.1 cascade controller to connect and run up to 8 identical units
- Soundproofed compressor cabinet (as in the picture), approximately 3–5 dBA reduction
- Heat Pump control, available on request

Water-cooled screw compressor chiller

YRW 151 to 301



Performances

YRW	151	201	251	301
Cooling capacity (kW)	143	195	236	306
Absorbed power (kW)	30.7	43.6	50.8	66.4
SEER ¹	5.57	5.29	5.52	5.33
EER	4.66	4.47	4.65	4.61
Regulation	25/50 ~ 100%			
Refrigerant charge (kg)	20	27	35	41
Evaporator	Inlet water temp. (°C)	12	12	12
	Outlet water temp. (°C)	7	7	7
	Waterflow (m³/h)	24.59	33.54	49.42
	Pressure drop (kPa)	11.2	13	15
Condenser	Inlet water temp. (°C)	30	30	30
	Outlet water temp. (°C)	35	35	35
	Waterflow (m³/h)	29.96	41.11	40.57
	Pressure drop (kPa)	16.2	22.3	12.1
Sound power level dB(A)	92	91	95	92
Max absorbed current (A)	90	125	155	195
Inrush current (A)	269	350	439	612
Power supply	400V /3PH/ 50Hz			

1: Ratings in accordance to Ecodesign, variable water flow and variable outlet (VW/VO).

The above data is based on Johnson Controls' selection software. Please refer to the latest version of the software for specific projects and available options. In the software you can also find the performance data for YRW-VS, the series with the inverter option.

Technical data

YRW	151	201	251	301
Dimensions	Length	1880		
	Width	800		900
	Height	1820		
Operating weight	1370	1510	1952	2063

Consult the software for the technical data of YRW-VS, the series with inverter option.



Manufacturer reserves the rights to change specifications without prior notice.

YCSE/YCRE Style C

Water-cooled screw compressor chiller

Cooling capacities from 140 kW to 249 kW

Heating capacities from 170 kW to 300 kW



YORK YCSE Style C chiller is designed for water or water-glycol cooling. It is designed for indoor installation in a plant room. The unit is completely factory assembled with all interconnecting refrigerant piping and wiring ready for field installation. **YCSE** unit is pressure tested, evacuated, and fully factory charged with refrigerant R134a and oil. After assembly, an operational test is performed with water flowing through the evaporator and condenser to ensure that each refrigerant circuit operates correctly. The units are also capable to be remodeled as a remote air-cooled screw compressor chiller condenser-less (**YCRE**).



Features

Model sizes

4 cooling only and 4 heat pumps.

Efficient screw compressors

YORK YCSE Style C offers the highest standard of reliability and economical operation utilizing twin-screw rotor technology and fully modulating compressor slide valve for increased part-load efficiency, together with low inrush current star-delta starters.

Quiet operation

The compressor has been designed so that there are minimal external gas pulsations. Thanks to the above and the adoption of integral oil separators YCSE units can achieve very low vibration and sound levels.

Small footprint

The compact design is ideally suited for reduced base area locations. The unit frame is manufactured from heavy-gauge galvanized steel coated with baked-on powder paint.

Extended Heating range

The operating range in heat pump mode has been extended, **YCSE Style C** units are now able to provide **heated water outlet up to 60°C**.

Modular concept

Provide flexibility

Up to 8 modules in one water system brings important benefits, such as:

- flexibility to fit in the existing space
- possible capacity increase in the future.

Achieve reliability

Full redundancy – safety first. Should a module fail, the remaining modules maintain operational continuity.

Options/Accessories

- Heat pump sensor kit, up to 60°C hot water production
- High chilled water setpoint available
- Brine down to -10°C setpoint
- Sound kit option, up to 15 dBA reduction

Nominal capacity and technical data

Model	YCSE				YCRE		
	0141	0181	0221	0241	0141	0181	0221
Size							
Cooling Capacity (kW) *	140	180	220	249	135	175	215
EER	4.85	4.81	4.71	4.73	4.22	4.19	4.10
SEER	5.27	5.46	5.51	5.52	Not Applicable		
η _{s,c}	208	215	217	218	Not Applicable		
Sound power level (dBA)	87	88	89	90	88	89	90
Length / Width / Height (mm)	Base 1378 max / 806 / 1681						
Operating weight (kg)	860	950	1040	1075	765	835	900

* YCSE: At 35°C leaving condenser liquid temperature and 7°C leaving chilled liquid temperature according to EUROVENT calculation EN14511:2011

* YCRE: At 45°C condensing temperature and 7°C leaving chilled liquid temperature

Ecodesign figures are calculated following fixed water and fixed outlet approach (FW/FO). For other Ecodesign calculations, please contact your JCI representative.

The above data is based on Johnson Controls' selection software YORKworks 21.04a. Please refer to the latest version of the software for specific projects

Dimensions and hydraulic connections

YCSE 0141 to 0241

NB1	Electrical Box
NB2	Customer Wiring Entry (both sides)
NB3	2 1/2" Victaulic Connection
NB4	76.1 mm Welded Connection

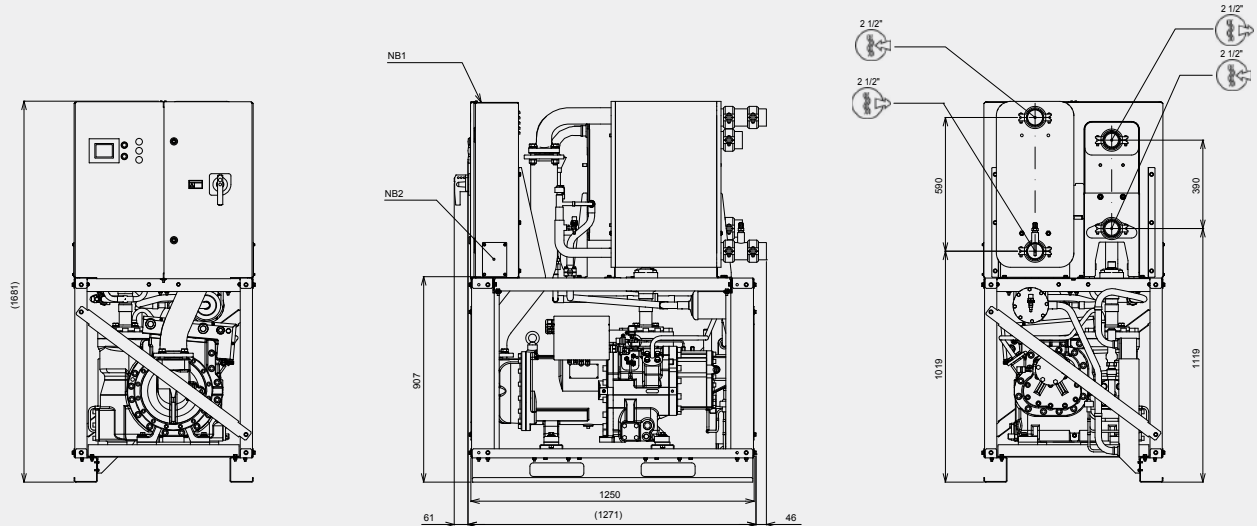

All dimensions in mm. Drawings not in scale.

YCRE 0141 to 0221

NB1	Electrical Box
NB2	Customer Wiring Entry (both sides)
NB3	28.58 mm Brazing Connection
NB4	53.98 mm Brazing Connection
NB5	2 1/2" Joint Connection
NB6	76.1 mm Welded Connection
NB7	Joint or Welded Connection

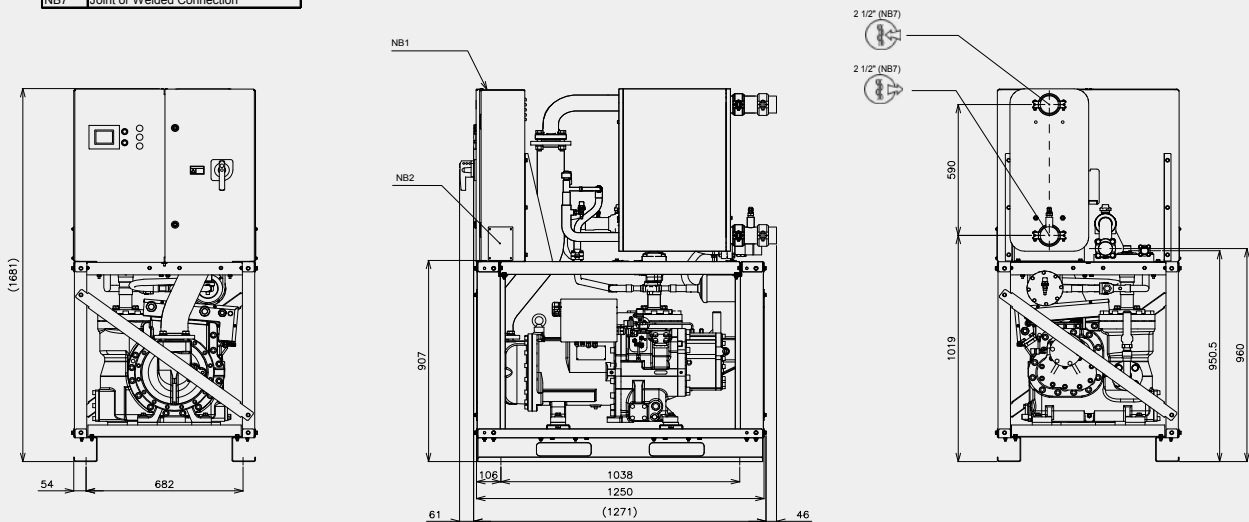

All dimensions in mm. Drawings not in scale.



Manufacturer reserves the rights to change specifications without prior notice.

YWH

Super-high temperature water to water scroll heat pumps

Heating capacities from 18.5 kW to 301.2 kW



Options

- HT** High source leaving water temperature up to 40°C, water temperature production up to 78°C.
- LT** Medium source leaving water temperature up to 20°C, water temperature production up to 70°C.
- XL** Floating frame and super low noise version, up to 12 dBA attenuation
- HK** Hydraulic kit, single or dual pump, for mod. 1804, 2304, 2604 only

Features

YWH heat pumps are designed with braze welded stainless steel AISI 316 heat exchangers and are particularly suitable for applications that use source energy at medium or high temperatures.

These units have been designed to produce water at high or very high temperature for applications where it is necessary to have maximum efficiency in heating. The units are available in heating only mode and can produce water up to 78°C (HT version).

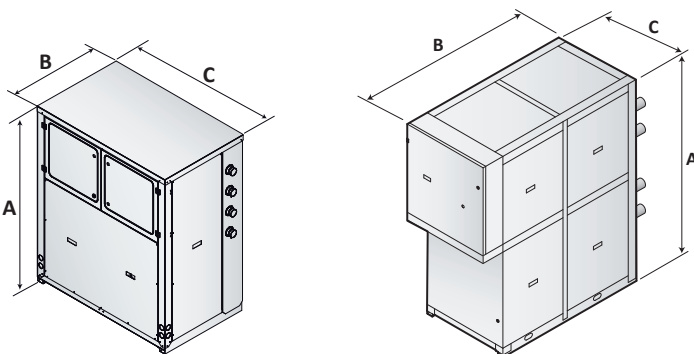

Mod.	A (mm)	B (mm)	C (mm)
161	1631	790	1145
211	1631	790	1145
312	1631	790	1145
412	1656	790	1145
612	1656	790	1145
712	1656	790	1145
912	1656	790	1145
1212	1656	790	1145
1412 LT	1656	790	1145

Mod.	A (mm)	B (mm)	C (mm)
1412 HT	1900	2177	794
1804	1900	3127	794
2304	1900	3127	794
2604	1900	3127	794

Operation limits HT version

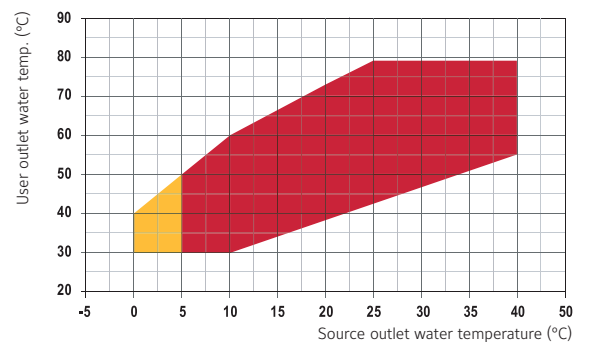

Operation limits LT version

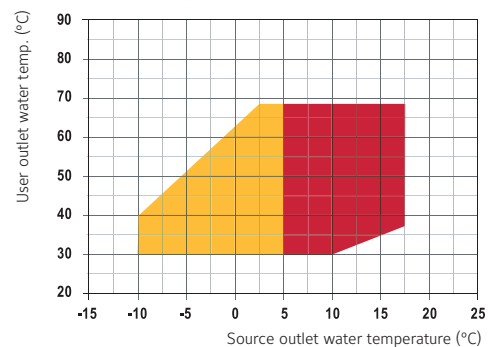

- Standard version with glycol
- Standard version

Super-high temperature water to water scroll heat pumps

YWH 161 to 2604



Nominal capacity

YWH LT/XL		312	412	612	712	912	1212	1412	1804	2304	2604
Heating capacity (EN14511) (1)	kW	38.8	46.0	58.4	70.3	88.4	109.9	136.5	176.9	219.5	273.2
Input power (EN14511) (1)	kW	8.2	9.4	11.8	14.8	18.8	23.1	27.9	37.2	45.7	55.3
COP (EN14511) (1)	W/W	4.73	4.85	4.93	4.76	4.70	4.75	4.88	4.75	4.80	4.94
Energy Class in low temperature (2)		A+++	A+++	A+++	A+++	A+++	A+++	A+++	A+++	A+++	A+++
SCOP low temperature (2)	kWh/kWh	4.85	5.00	5.16	5.00	5.08	5.17	5.36	5.29	5.38	5.56
$\eta_{s,h}$ low temperature (2)	%	185.9	192.1	198.2	191.8	195.3	198.9	206.3	203.4	207.0	214.4
Energy Class in medium temperature (2)		A++	A++	A++	A++	A++	A++	A++	A++	A++	A++
SCOP medium temperature (2)	kWh/kWh	4.07	4.19	4.28	4.18	4.16	4.22	4.35	4.27	4.34	4.47
$\eta_{s,h}$ medium temperature (2)	%	154.8	159.6	163.0	159.0	158.3	160.9	165.9	162.8	165.6	170.7
Power supply	V/Ph/Hz	400/3/50									
Maximum input current	A	128.7	137.6	168.0	209.0	266.0	324.0	372.5	348.0	428.0	497.5
Peak current	A	35.4	39.2	56.0	70.0	82.0	104.0	125.0	164.0	208.0	250.0
Compressors / Circuits	n°/n°	2-1	2-1	2-1	2-1	2-1	2-1	2-1	4-2	4-2	4-2
Capacity steps	n°	2	2	2	2	2	2	2	4	4	4
Refrigerant		R134a									
Global warming potential (GWP)		1430									
Refrigerant charge	Kg	2	2	3	3	4	5	6	8.5	10.5	13
Equivalent CO2 charge	t	2.9	2.9	4.3	4.3	5.7	7.2	8.6	12.2	15.0	18.6
Sound power LS version (3)	dB(A)	--	--	--	--	--	--	--	88	89	91
Sound pressure LS version (4)	dB(A)	--	--	--	--	--	--	--	72	73	75
Sound power XL version (3)	dB(A)	65	65	70	73	74	76	78	--	--	--
Sound pressure XL version (4)	dB(A)	49	49	54	57	58	60	62	--	--	--

(1) Heating: user water temperature 30/35°C, source water temperature 10/7°C.

(2) Ratings in accordance with Ecodesign regulation 813/2013, average climatic profile and variable water outlet temperature.

(3) Sound power level in accordance with ISO 3744.

(4) Sound pressure level at 1 m from the unit in free field conditions in accordance with ISO 3744.

Nominal capacity

YWH HT/XL		161	211	312	412	612	712	912	1212	1412	1804	2304	2604
Heating capacity (EN14511) (1)	kW	18.5	21.8	37.6	43.6	64.1	75.1	97.8	121.7	150.5	195.6	243.9	301.2
Input power (EN14511) (1)	kW	3.4	3.7	6.7	7.5	11.1	13.7	17.6	21.7	26.2	35.0	43.1	52.2
COP (EN14511) (1)	W/W	5.64	5.89	5.65	5.83	5.79	5.48	5.56	5.62	5.74	5.59	5.65	5.77
Energy Class in low temperature (2)		A+++	A+++	A+++	A+++	A+++	A+++	A+++	A+++	A+++	A+++	A+++	A+++
SCOP low temperature (2)	kWh/kWh	5.79	5.90	5.71	5.83	5.91	5.81	5.85	5.94	6.09	5.95	6.01	6.20
$\eta_{s,h}$ low temperature (2)	%	223.7	229.2	220.2	225.3	228.2	224.5	226.0	229.4	235.6	230.0	232.4	239.9
Energy Class in medium temperature (2)		A+++	A+++	A++	A++	A++	A++	A++	A++	A++	A++	A++	A++
SCOP medium temperature (2)	kWh/kWh	4.40	4.53	4.62	4.73	4.78	4.76	4.67	4.74	4.85	4.73	4.79	4.91
$\eta_{s,h}$ medium temperature (2)	%	168.1	173.5	176.9	181.1	183.2	182.2	178.7	181.5	186.1	181.0	183.6	188.3
Power supply	V/Ph/Hz	400/3/50											
Maximum input current	A	95	111	111.4	128.7	167.1	208.3	267.9	324.8	372.9	353.7	430.4	498.7
Peak current	A	16.4	17.7	32.8	35.4	54.2	68.6	85.8	105.6	125.8	171.6	211.2	251.6
Compressors / Circuits	n°/n°	1-1	1-1	2-1	2-1	2-1	2-1	2-1	2-1	2-1	4-2	4-2	4-2
Capacity steps	n°	1	1	2	2	2	2	2	2	2	4	4	4
Refrigerant		R134a											
Global warming potential (GWP)		1430											
Refrigerant charge	Kg	3	3	4	4	5	6	8	10	10	21	26	33
Equivalent CO2 charge	t	4.3	4.3	5.7	5.7	7.2	8.6	11.4	14.3	14.3	30.0	37.2	47.2
Sound power LS version (3)	dB(A)	--	--	--	--	--	--	--	--	--	88	89	91
Sound pressure LS version (4)	dB(A)	--	--	--	--	--	--	--	--	--	72	73	75
Sound power XL version (3)	dB(A)	62	62	65	65	70	73	74	76	78	--	--	--
Sound pressure XL version (4)	dB(A)	46	46	49	49	54	57	58	60	62	--	--	--

(1) Heating: user water temperature 30/35°C, source water temperature 10/7°C.

(2) Ratings in accordance with Ecodesign regulation 813/2013, average climatic profile and variable water outlet temperature.

(3) Sound power level in accordance with ISO 3744.

(4) Sound pressure level at 1 m from the unit in free field conditions in accordance with ISO 3744.



Manufacturer reserves the rights to change specifications without prior notice.

YWW

Water-cooled chillers and heat pumps with Scroll compressors

Cooling capacities from 53 kW to 367.2 kW

Heating capacities from 69.9 kW to 464.7 kW



Features

- Low GWP Refrigerant: R454B (also R410A available as option)
- Cooling only and reversible heat pump (4 way valve)
- On-off compressor
- Plate heat exchangers (P models) and Shell & Tube as alternative models
- Hot water up to **50°C**
- Heat recovery
- High Efficiency: SEER up to 6.15
- Full Control with Web Monitoring (option)
- Different Noise Levels: Standard - Silent - Super Silent

Operating limits cooling mode

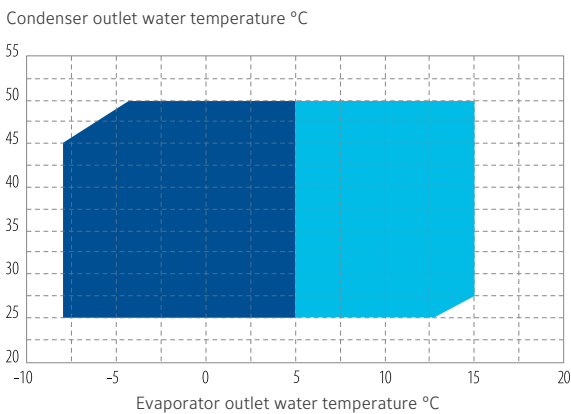

- Standard operation
- Operation with Low water temperature kit

Operating limits heating mode

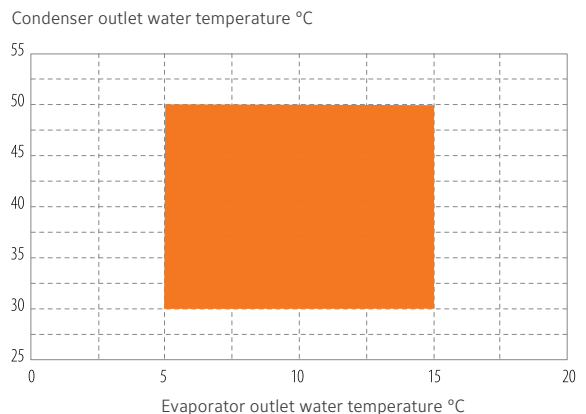

- Standard operation

Water-cooled chillers and heat pumps with Scroll compressors

YWW-SRL 0055 to 0365



Technical features SRL-P models (R454B)

YWW_SRL-P - Plate Heat Exchangers			0055	0060	0070	0080	0095	0105	0125	0145	0165	0190
Cooling only ¹	Cooling Capacity	kW	53.0	59.8	69.0	78.9	93.0	107.6	124.9	143.2	162.8	187.1
	EER		4.08	4.11	4.09	4.15	4.22	4.1	4.35	4.35	4.31	4.28
	SEER ²		5.23	5.17	5.17	5.16	5.58	5.15	5.66	6.11	5.72	6.10
Heating only ³	Heating Capacity	kW	69.9	77.2	89.8	101	116.3	134.6	152.9	173	197	227.7
	COP		3.85	3.85	3.86	3.92	4.04	4.02	3.98	4.04	3.83	4.03
	SCOP ⁴		4.25	3.99	4.72	5.1	5.06	5	5.32	5.26	4.71	4.71
Dimensions	Height	mm	1520	1520	1520	1520	1520	1520	1520	1520	1520	1520
	Length	mm	1200	1200	1200	1200	1200	2285	2285	2285	2285	2285
	Width	mm	830	830	830	830	830	830	830	830	830	830

YWW_SRL-P - Plate Heat Exchangers			0215	0240	0260	0295	0330	0365
Cooling only ¹	Cooling Capacity	kW	214.7	239.6	262.6	295.2	330.7	367.2
	EER		4.06	4.14	4.09	4.12	4.17	4.23
	SEER ²		5.22	5.46	5.50	5.81	5.55	5.93
Heating only ³	Heating Capacity	kW	278.6	307.3	335.3	378.4	419.6	464.7
	COP		4.19	4.15	4.16	4.27	4.15	4.21
	SCOP ⁴		5.18	5.31	5.44	5.45	5.71	5.65
Dimensions	Height	mm	1900	1900	1900	1900	1900	1900
	Length	mm	2500	2500	2500	2500	3000	3000
	Width	mm	800	800	800	800	800	800

Technical features SRL models (R454B)

YWW_SRL - Shell & Tube exchangers			0055	0060	0070	0080	0095	0105	0125	0145	0165	0190
Cooling only ¹	Cooling Capacity	kW	54.6	59.9	67.9	79.2	94.0	106.1	123.5	144.6	164.8	187.8
	EER		4.19	4.24	4.14	4.15	4.24	4.11	4.37	4.36	4.32	4.27
	SEER ²		5.16	5.17	5.16	5.17	5.65	5.17	5.68	6.15	5.77	6.13
Heating only ³	Heating Capacity	kW	71.7	77.3	88.2	102	117.3	133.6	151.9	174.9	199.9	228.6
	COP		3.9	3.89	3.86	3.9	4.02	4.02	4	4.08	3.84	4.03
	SCOP ⁴		4.12	4.35	4.35	4.48	4.57	4.52	4.8	4.59	4.67	4.79
Dimensions	Height	mm	1300	1300	1300	1300	1300	1300	1300	1300	1450	1450
	Length	mm	2100	2100	2300	2100	2700	2400	2400	2400	2400	2600
	Width	mm	830	830	830	830	830	830	830	830	830	830

YWW_SRL - Shell & Tube exchangers			0215	0240	0260	0295	0330	0365
Cooling only ¹	Cooling Capacity	kW	215.7	237.8	259.7	289.6	328.9	359.7
	EER		4.1	4.21	4.11	4.07	4.21	4.14
	SEER ²		5.26	5.46	5.46	5.61	5.52	5.75
Heating only ³	Heating Capacity	kW	279.4	304.4	331.2	370.5	416.6	454.9
	COP		4.22	4.16	4.16	4.14	4.15	4.1
	SCOP ⁴		4.88	5.15	5.08	4.92	5.21	4.99
Dimensions	Height	mm	1900	1900	1900	1900	1900	1900
	Length	mm	3000	3000	3000	3000	3000	3000
	Width	mm	800	800	800	800	1350	1350

1. Cooling capacities in kW given for 12/7°C water leaving temperature Δt 5°C and 35°C ambient temperature.
 2. Seasonal energy efficiency of cooling at low temperature. According to EU Regulation n. 2016/2281.
 3. Heating capacities in kW given for 40/45°C water leaving temperature and 7°C ambient temperature.
 4. Seasonal energy efficiency of heating at low temperature with average climatic conditions. According to EU Regulation n. 813/2013.
- The above table only shows net (EN14511) performance values of YWW units operating with R454B refrigerant although they are also available with R410A. For more information, please contact your Johnson Controls representative.



Manufacturer reserves the rights to change specifications without prior notice.

YWW

Water-cooled chillers with Screw compressors

Cooling capacities from 86.3 kW to 188.8 kW



Features

- Low GWP Refrigerant: R1234ze
- Cooling only or HP control logic
- Stepless or Inverter compressor
- Plate Heat Exchangers
- Hot water up to **65°C**
- Heat recovery
- High Efficiency: SEER up to 5.60
- Full Control with Web Monitoring (option)
- Different Noise Levels: Standard and Super Silent

On Board Controller with LCD Display

Communication controller with included display mounted on unit's door. Communication controller-display through proprietary device.

Connection to peripheral equipment takes place through a gateway via CANBUS connection.

- 3 levels of access: user – service – manufacturer
- 4 push buttons and digital icons visualization

Operating limits

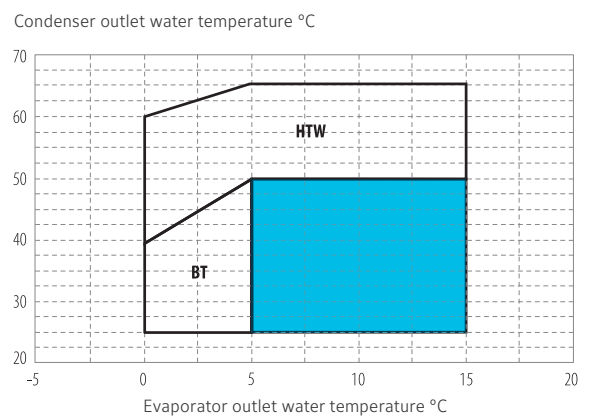

- Standard operation
- BT Operation with Low water temperature kit
- HTW Device for high temperature water production

Water-cooled chillers with Screw compressors

YWW-SCH-P 0085 to 0190



Technical features (R1234ze)

YWW_SCH-P model			0085	0115	0150	0190
Cooling only ¹	Cooling Capacity	kW	86.3	114.9	151.9	188.8
	Power input	kW	17.1	22.1	29.4	36
	EER		5.05	5.20	5.17	5.24
	SEER ²		5.51	5.49	5.55	5.60
Dimensions	Height	mm	1620	1620	1620	1620
	Length	mm	2800	2800	2800	2800
	Width	mm	730	730	730	730

1. Cooling capacities in kW given for 12/7°C water leaving temperature Δt 5°C and 35°C ambient temperature.

2. Seasonal energy efficiency of cooling at low temperature. According to EU Regulation n. 2016/2281.

Heat pump control logic available – non reversible unit – for hot water production up to 65°C.

The above table shows net (EN14511) performance values of YWW units.

Contact with your JCI representative to evaluate the exact heating performance and capacity range.

Inverter Control (option) Screw Compressor

Designed for high temperature applications: high power and efficiency

- High efficiency screw Rotor profile – hyper volumetric efficiency.
- High efficiency motor.
- Capacity control with Inverter regulation.
- ECONOMIZER.
- Low friction components: high reliability and efficiency.
- High performance INTEGRAL OIL SEPARATOR.

The screw compressor is managed by an **Inverter Variable Frequency Drive** that electronically modulates the compressor speed according to the required cooling load.

- Delivered & absorbed power is PROPORTIONALLY modulated on the compressor with Inverter.
- No step regulation.
- Minimized absorbed power when working at part load.

Compressor design for HFO-R1234ze

- Specific POLYESTER OIL.
- Specific COMPRESSOR GASKETS.
- New RELIEF VALVES.



Manufacturer reserves the rights to change specifications without prior notice.

YVWH

Premium-efficiency VSD water-cooled screw compressor chiller

Cooling capacity: 313 kW to 1189 kW (R1234ze/R515B) - 1566 kW (R513A/R134a)

Heating capacity: 315 kW to 1250 kW (R1234ze/R515B) - 1730 kW (R513A/R134a)

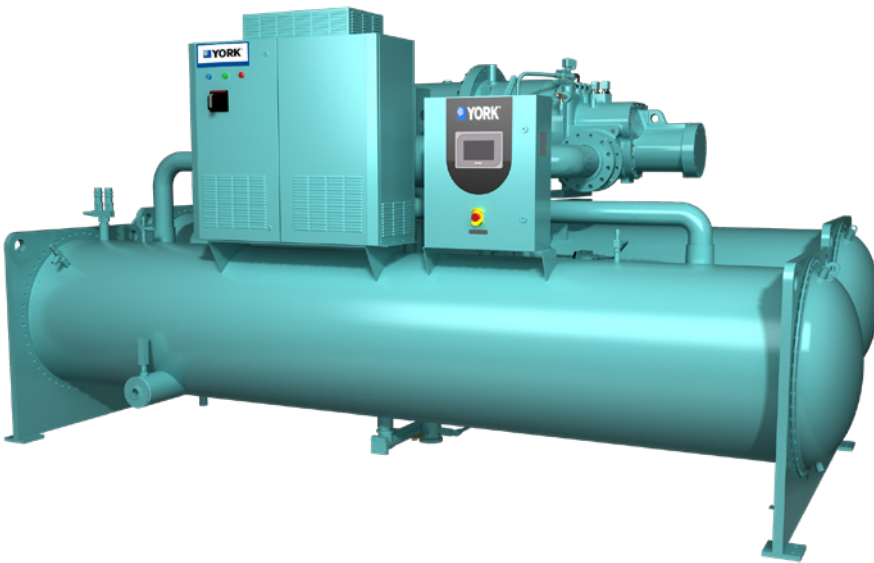

Features

YVWH is innovatively designed and manufactured, it offers **premium efficiency** at both full load and part load condition, helping the customer achieving the greatest value. Thanks to the combination of high efficiency and the use of the new 4th generation **HFO refrigerant R1234ze**, the chiller SEER surpasses the Ecodesign Tier 2 requirement and contributes to the reduction of the CO2 emissions.

Key components

- Optimized motor and flow structure design ensure high compressor efficiency
- Optimized compressor with variable Vi design further enhances partload performance
- Built-in condenser oil separator increases the oil separation effectiveness
- Counterflow subcooler design provides the most optimized subcooling

Committed to sustainability

- Low GWP solution with new refrigerant R1234ze (GWP = 7, F-Gas)
- R1234ze and R134a refrigerants protect the ozone layer (ODP = 0) and have no phase out date
- Chiller SEER exceeding by far Ecodesign Tier 2 requirements
- Premium chiller efficiency brings green building effectiveness to a remarkable level

Options/Accessories

- Heat pump up to **50°C** water production, with R1234ze
- Spring isolators
- Left/right pipe connection
- Sound kit up to 10 dB(A) reduction
- Thicker evaporator insulation
- Refrigerant isolation valve
- Harmonic filter

Refer to <https://www.ahrinet.org/certification/ahri-certification-programs> for water cooled Program Scope, Inclusions, and Exclusions as some options listed herein fall outside the scope of the AHRI certification program. For verification of certification, go to the AHRI Directory at www.ahridirectory.org

Premium-efficiency VSD water-cooled screw compressor chiller

YVWH 115 to 445

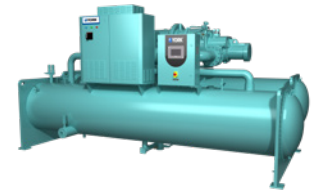

Performances (R1234ze and R515B)

YVWH		115	145	180	225	265	305	325	380	445	
Cooling capacity	kW	313.3	389.3	481.5	602.1	721.7	799.7	882.8	1033.0	1189.0	
Optimized compressor (Variable Vi)	EER	6.23	6.41	6.19	6.41	6.25	6.25	6.07	6.24	6.13	
	SEER	8.61	8.81	8.85	9.13	9.31	9.31	9.68	10.01	9.82	
	η_{sc}	341.44	349.57	351.17	362.27	369.36	369.36	384.34	397.44	389.9	
Evaporator	Pass	4				2					
	Flow rate	l/s	15.00	19.23	23.56	28.82	33.11	39.63	42.22	49.54	58.71
	Piping dimension	mm	125		150		200				
	Pressure drop	kPa	44.5	53.6	53.3	51.6	43.0	37.2	19.6	27.1	32.8
Condenser	Pass	4				2					
	Flow rate	l/s	17.56	22.42	27.55	33.61	38.75	46.18	49.53	57.87	68.74
	Piping dimension	mm	125		150		200				
	Pressure drop	kPa	43.6	52.6	52.4	52.4	45.9	32.7	21.7	24.5	34.3
Refrigerant circuit	n.					1					
Compressor quantity	n.					1					
Capacity control %						15-100%					
Refrigerant charge	kg	200		240	250	360	370	400	410	510	
Sound pressure level (1m) ¹	dBA	78	80	82	84	80	85	87	89	91	

Ratings in accordance to Ecodesign, variable water flow and variable outlet (VW/VO). Rated with Selection Navigator SN24.12.

For other Ecodesign calculations or R513A/R134a information, please contact your JCI Representative.

¹ Bare unit. Sound kit 1 or 2 are available for sound attenuation.

Technical data

YVWH		115	145	180	225	265	305	325	380	445
Dimensions	Length	mm	3118	3131	3154	3156	4807	4832	4873	
	Width	mm	1710	1797	1975	2005	1925	1988	2086	
	Height	mm	1966	1996	2124	2250	2300		2320	
Operating weight	kg	4387	5169	6350	6951	7834	8894	9306	9983	

Soft Start

YVWH provides a soft start without current shock. The start-up current will never be larger than the rating current, which benefits the customer with lower cost on associated equipment and smaller backup generator and quick start function in case of the shutdown due to power supply failure.

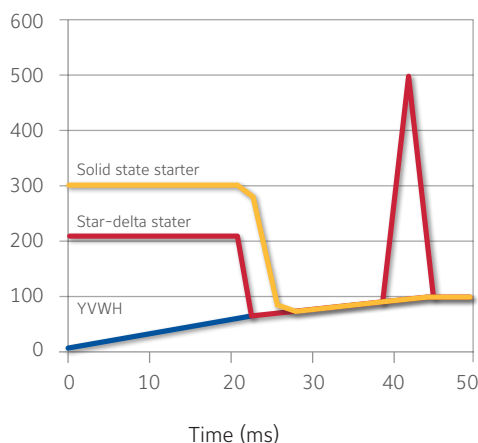

Displacement Power Factor (DPF)

The Variable Speed Drive (VSD) design makes 0.95 high DPF achievable in standard YVWH models at all operating conditions. For traditional non-VSD designed screw chiller, the DPF will reduce when the cooling load goes down.

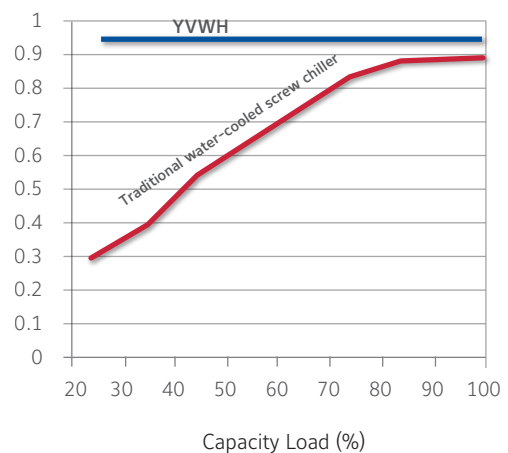

Manufacturer reserves the rights to change specifications without prior notice.

YVWH main features

Variable Vi

Premium efficiency water-cooled screw chillers from YORK® control the refrigerant volume ratio (Vi) to match the pressure ratio, which helps maintain optimum compressor efficiency. YORK® was the first manufacturer to offer this technology, and our step-less control with perfectly matched compressor and system Vi can provide up to 10% SEER performance improvement (average 6% across the range) vs fixed Vi systems.

Performance Improvement by Variable Vi

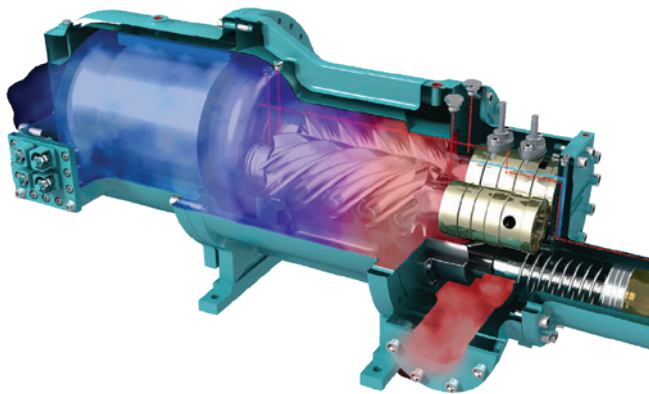
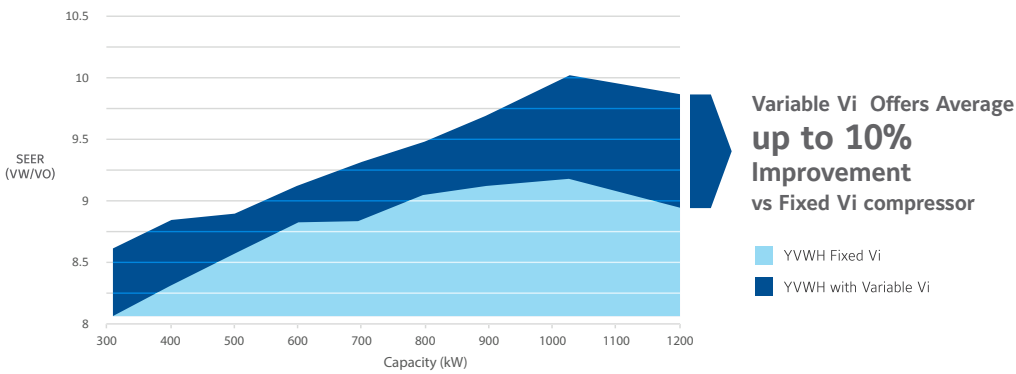

Optimized Compressor

Screw compressors from YORK® use advanced technology to deliver higher efficiencies. Optimized variable volume ratio compressor design matches compression to the load to avoid over-compression and wasted energy. A special rotor design provides a tight seal and high compression efficiency. A compact design with simple assembly provides easier maintenance. Together, these technological enhancements increase efficiency while reducing noise and vibration.

Reduced Sound Pressure Levels (1m)

A unique, patented dampening structure in the YORK® screw compressor is combined with an integrated oil separator to reduce noise. These technologies result in operating sound levels up to 17 dBA quieter than traditional chillers while maintaining peak efficiency.

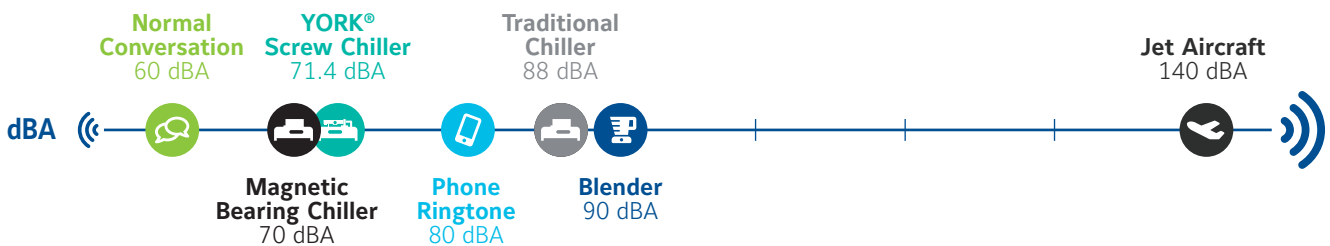

Dimensions and hydraulic connections

YVWH 115/145/180/225

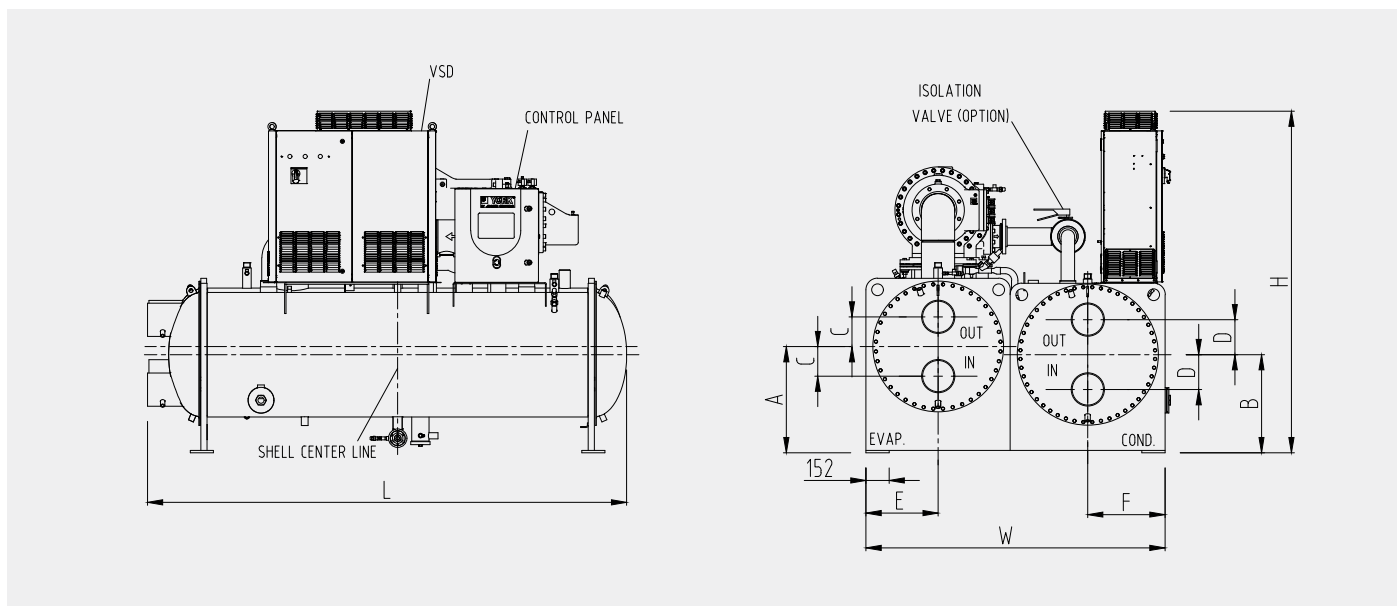

Model	L (mm)	W (mm)	H (mm)	A (mm)	B (mm)	C (mm)	D (mm)	E (mm)	F (mm)
YVWH115	3118	1710	1966	644	566	190	180	400	435
YVWH145	3131	1797	1996	694	586	165	180	425	450
YVWH180	3154	1975	2124	709	646	230	230	460	520
YVWH225	3156	2005	2250	699	646	230	230	475	510

All dimensions in mm. Drawings not in scale.

YVWH 265/305/325/380/445

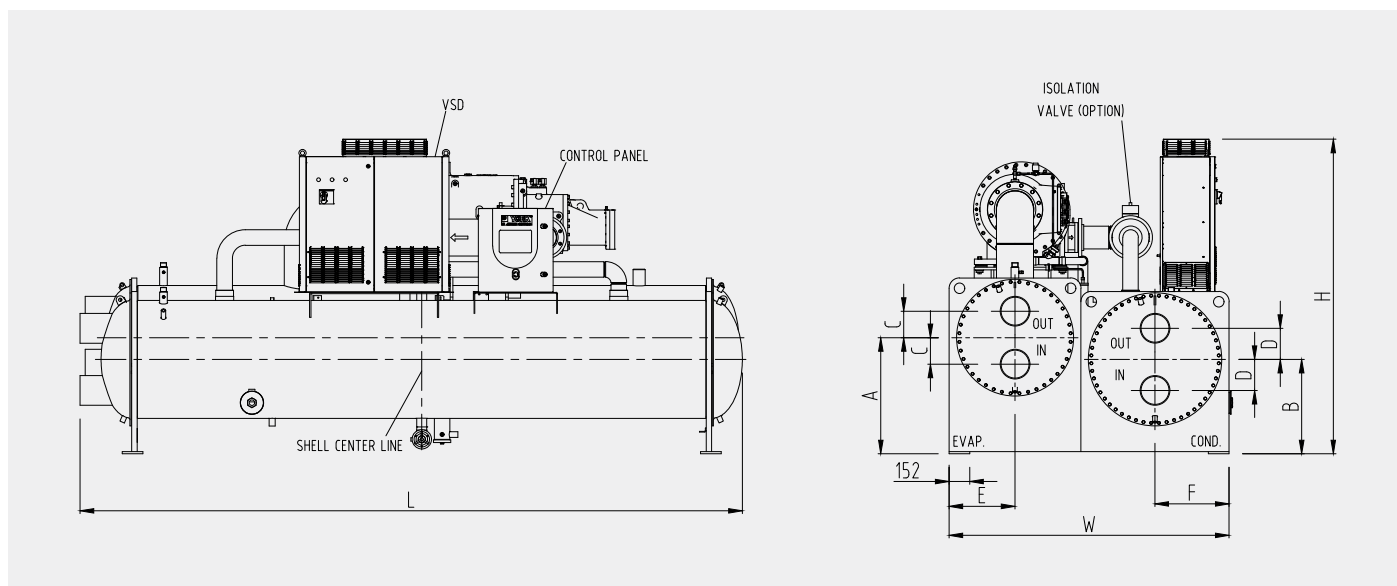

Model	L (mm)	W (mm)	H (mm)	A (mm)	B (mm)	C (mm)	D (mm)	E (mm)	F (mm)
YVWH265	4807	1925	2300	856	696	195	195	460	485
YVWH305	4832	1988	2300	856	696	195	230	460	520
YVWH325/380/445	4873	2086	2320	856	696	195	229	485	545

All dimensions in mm. Drawings not in scale.

YVWH HP

Premium-efficiency VSD water-cooled screw compressor heat pump

Cooling capacity: 792 kW to 1586 kW

Heating capacity: 900 kW to 1800 kW

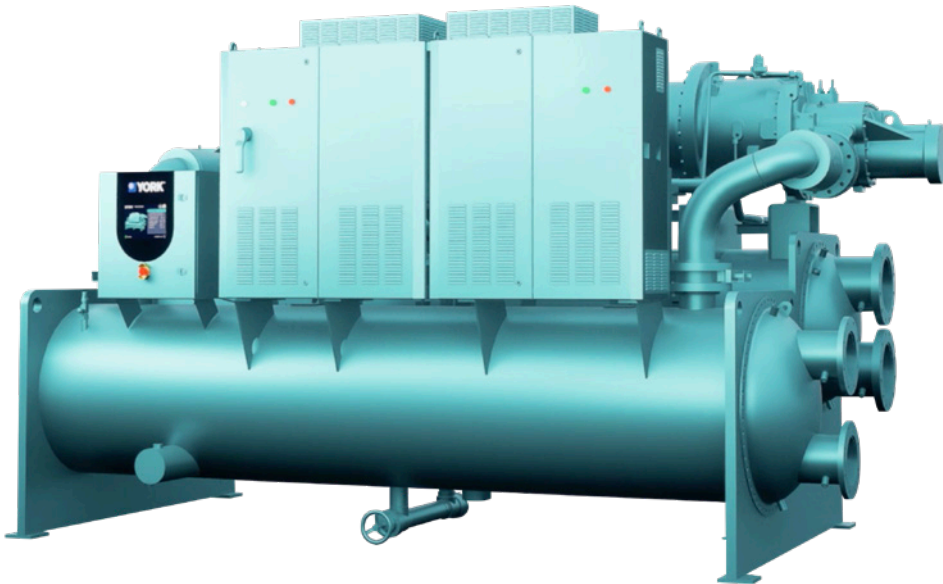

Features

YVWH HP is innovatively designed and manufactured. It is a sustainable, cost-effective alternative to traditional boiler and chiller systems and ideal for commercial buildings, hospitals, industrial processes and district energy applications.

It offers **premium efficiency** at both full load and part load condition of cooling and heating, helping the customer achieving the greatest value. Thanks to the combination of high efficiency and the use of the new 4th generation **HFO refrigerant R1234ze**, the heat pump SCOP surpasses the Ecodesign Tier 2 requirement and contributes to the reduction of the CO₂ emissions.

Key components

- High-head compressor capable to provide high-temperature hot water up to 80°C
- Compressor with variable Vi design delivers optimized efficiency of heating and cooling
- Variable-speed drive helps achieve premium off-design performance
- Economizer design increases the cycle efficiency and heating capacity
- Built-in condenser oil separator increases the oil separation effectiveness
- Counterflow subcooler design provides the most optimized subcooling

Committed to sustainability

- Achieve sustainability goals by reducing fossil fuel-fired boilers
- More than 2 times efficient than typical boiler reduces energy consumption and CO₂ emissions
- Low GWP solution with new refrigerant R1234ze (GWP = 7, F-Gas)
- Alternate R515B refrigerant available
- R1234ze and R515B refrigerants protect the ozone layer (ODP = 0) and have no phase out date
- Heat pump SCOP exceeding by far Ecodesign Tier 2 requirements

Options/Accessories

- Spring isolators
- Left/right pipe connection
- Refrigerant isolation valve
- Harmonic filter (floor mounted)

Premium-efficiency VSD water-cooled screw compressor heat pump

YVWH HP 270 to 550

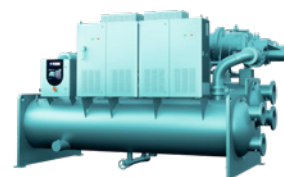

Performances (R1234ze and R515B)

YVWH HP		270	370	450	550	
Heating range at 12/7 - 60/65°C						
Heating capacity	kW	900	1245	1440	1800	
COP		3.34	3.33	3.38	3.33	
Heating range at 10/7 - 40/45°C						
Heating capacity	kW	931	1260	1480	1850	
COP		5.19	5.16	5.24	5.18	
Ecodesign Medium Temperature Heat Pump						
SCOP ^{(1), (2)}		5.21	5.14	5.16	5.21	
η_s, h ^{(1), (2)}		200.4	197.6	198.4	200.4	
Cooling Range at 12/7 - 30/35°C						
Cooling capacity	kW	792.2	1096	1273	1586	
EER		5.43	5.44	5.48	5.46	
SEER ⁽²⁾		7.49	8.14	8.38	8.56	
η_s, c ⁽²⁾	%	296.5	322.8	332.2	339.2	
Sound pressure @ 1m		84.5	86.5	87.5	88.5	
Evaporator	Pass	2	2	2	2	
	Flow rate	l/s	37.6	52.09	60.35	75.17
	Piping dimension	mm	150	200	200	250
	Pressure drop	kPa	58.8	55.2	55.9	51.8
Condenser	Pass	2	2	2	2	
	Flow rate	l/s	44.6	61.81	71.5	89.19
	Piping dimension	mm	150	200	200	250
	Pressure drop	kPa	71.6	71.1	71.5	71.9
Refrigerant circuit	n.	1	1	1	1	
Compressor quantity	n.	1	2	2	2	
Refrigerant charge	kg	300	400	420	460	

1) Ratings in accordance to Ecodesign at 10/7 - 47/55°C

2) Ratings variable water flow and variable outlet (VW/VO).

3) The table above shows only a representative sample of performance points. For job specific operating conditions contact your JCI Representative.

Technical data

YVWH		270	370	450	550	
Dimensions	Length	mm	4169	4235	4235	4543
	Width	mm	2005	2140	2160	2240
	Height	mm	2110	2456	2482	2541
Operating weight	kg	6908	9391	10286	12399	
Shipping weight	kg	6417	8660	9442	11345	

GT Screw Compressor



Variable Speed Drive



OptiView LT Panel



Manufacturer reserves the rights to change specifications without prior notice.

YZ Magnetic bearing centrifugal chiller

Cooling capacities from 580 kW to 5500 kW



“Tailor and tune”
customized units around
job specific design.

Features

The **YORK YZ Magnetic Bearing Centrifugal Chiller** is a revolutionary advancement that challenges everything about conventional chiller design. Built upon decades of industry-leading chiller expertise, our engineers questioned every component, analyzed every function and challenged every assumption. The result is the first chiller fully optimized for ultimate performance with a next generation low-GWP (global warming potential) refrigerant, delivering **superior real-world performance, lower cost of ownership and a new definition of sustainability**. It's the first chiller built to exceed every expectation – today and tomorrow.

The design premise for the **YORK YZ** was simple: Don't just make a new chiller – make the best chiller for our customers. This was accomplished through a holistic approach to system design and engineering, optimizing every component around a carefully selected next generation refrigerant for ultimate performance.

Committed to sustainability

- Low GWP solution with new refrigerant R1233zd (GWP = 4.5, F-Gas)
- R1233zd refrigerant protect the ozone layer and have no phase out date
- Chiller SEER exceeding by far Ecodesign Tier 2 requirements
- Premium chiller efficiency brings green building effectiveness to a remarkable level

Magnetic bearing centrifugal chiller

YZ



Proven Firsts

Groundbreaking YORK innovations refined over decades of real-world use have been brought together to create a revolution in chiller design and optimization. It's everything we've learned to-date, and then some.

Variable-Speed Drive:

Four decades ago, YORK introduced the first variable-speed drive (VSD) chiller. And we've since installed more VSD chillers than all other manufacturers combined. A VSD is standard on the YORK YZ.

Magnetic Bearing Driveline:

In 1998, YORK Navy Systems pioneered reliable magnetic-bearing technology to cool submarines. The same durable and efficient technology is used on the YORK YZ.

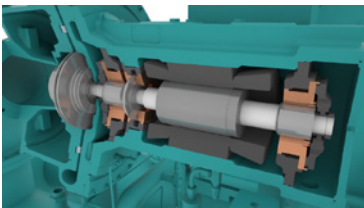

Optimized Compressor:

An optimized, single-stage design enables YORK chillers to provide the best possible real-world energy efficiency. YORK YZ compressors also lead the industry with the widest operating range at off-design conditions where systems most often operate. New advanced aerodynamic system has been designed to operate with low GWP refrigerant R1233zd.

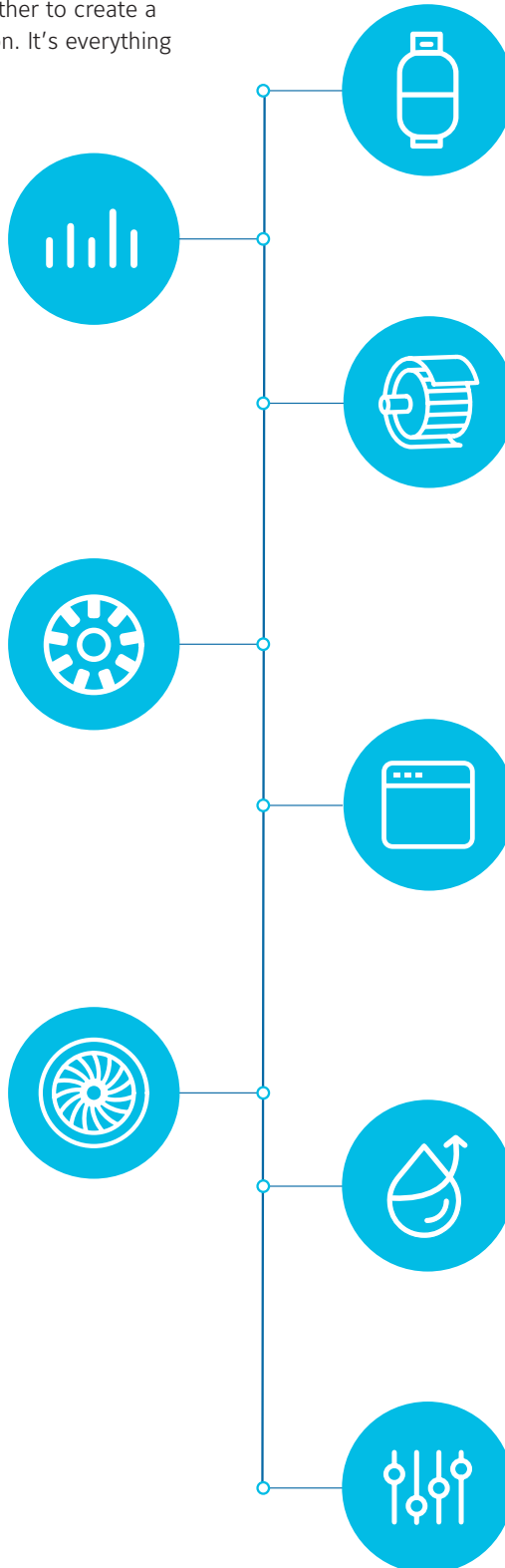
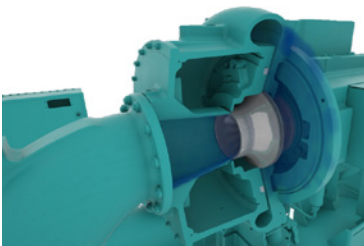

Low-Pressure Chiller:

For most of the past century, the YORK centrifugal chiller portfolio has offered low-pressure refrigerants to deliver high-efficiency chillers. The YORK YZ is designed to maximize the efficiency of a new, low-GWP, low-pressure refrigerant.

High-Speed Hermetic Induction Motor:

YORK was the first to combine low-maintenance, hermetically-sealed induction motors with variable-speed drives in 2004 to directly drive the compressors in air-cooled chillers. The YORK YZ builds on this reliable, proven technology to power our latest generation of centrifugal compressors.

OptiView Control Panel with Connected Service:

The full-color, interactive OptiView control panel of the YORK YZ offers over 100 setpoints, readouts, alerts and trending reports. In addition, data can be securely connected to the cloud-based analytics platform for remote monitoring and predictive diagnostics – another innovation first brought to you in YORK chillers. It is the same control system of YK and YMC².

Falling Film Evaporator:

The YORK-patented falling film design of the YORK YZ reduces refrigerant charge up to 60%, and reduces evaporator shell size up to 20%, compared to other flooded, low-pressure refrigerant designs. The YORK patented falling film design also eliminates the need for a refrigerant pump.

Capacity Control Logic:

This patented YORK control technology provides rapid response to the load on the building, ensuring the YORK YZ Chiller does not waste energy or work harder than needed.



Manufacturer reserves the rights to change specifications without prior notice.

Magnetic Driveline Superiority

The YZ variable-speed drive and advanced magnetic bearing lubrication free design deliver extraordinary efficiency, superior durability, simplified maintenance and a wider operating envelope than any chiller using oil- or refrigerant-lubricated compressor bearings.

Ultimate Performance Efficiency

Thanks to magnetic bearing and lubrication free design YZ can run stably in the whole envelope shown in figure.

It provides highest energy efficiency when running at any low head condition, especially below 16°C water temperature inlet in the condenser (ECWT) where most of conventional chillers cannot operate.

YZ can take benefit of minimum lift applications, with **COP as high as 38**.

In the extra-low ECWT area on the map, running at low lift conditions (e.g. Data center) can occur at higher leaving evaporator temperatures, similar efficiencies can be achieved.

Note: The operating map can vary, please contact your JCI Representative for project specific details.

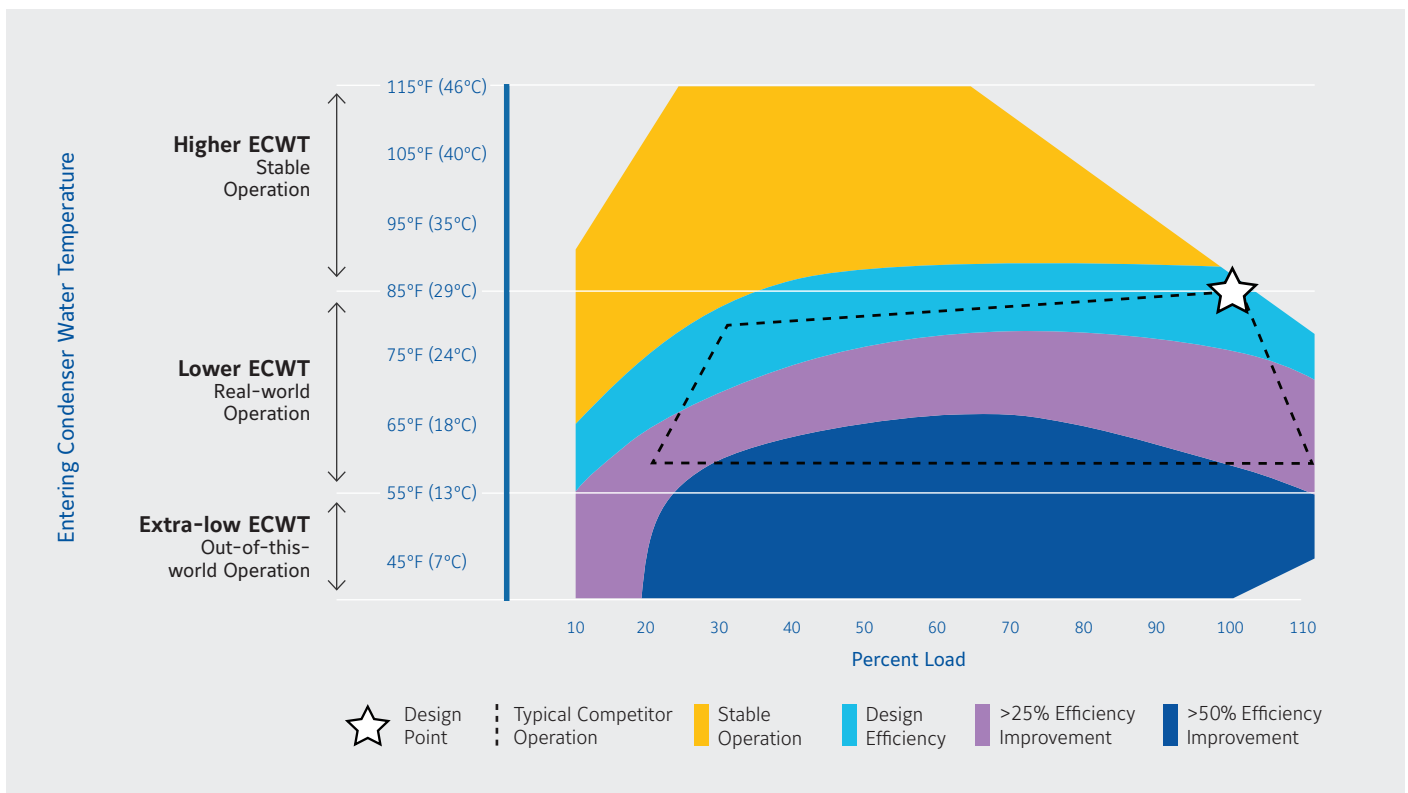

Minimum Driveline Maintenance and Costs of Ownership

YZ driveline features a single moving assembly suspended in a magnetic field that does not require lubrication.

With fewer moving parts than traditional oil- or refrigerant-lubricated drivelines **longevity is enhanced and maintenance is reduced.**

The chart compares driveline maintenance (assuming other scheduled maintenance tasks are equal across centrifugal chillers)

Magnetic bearings and lubrication free designs mean:

- No scheduled compressor/motor teardowns; components are designed to last the life of the chiller
- No required filter changes
- No complex lubrication system maintenance

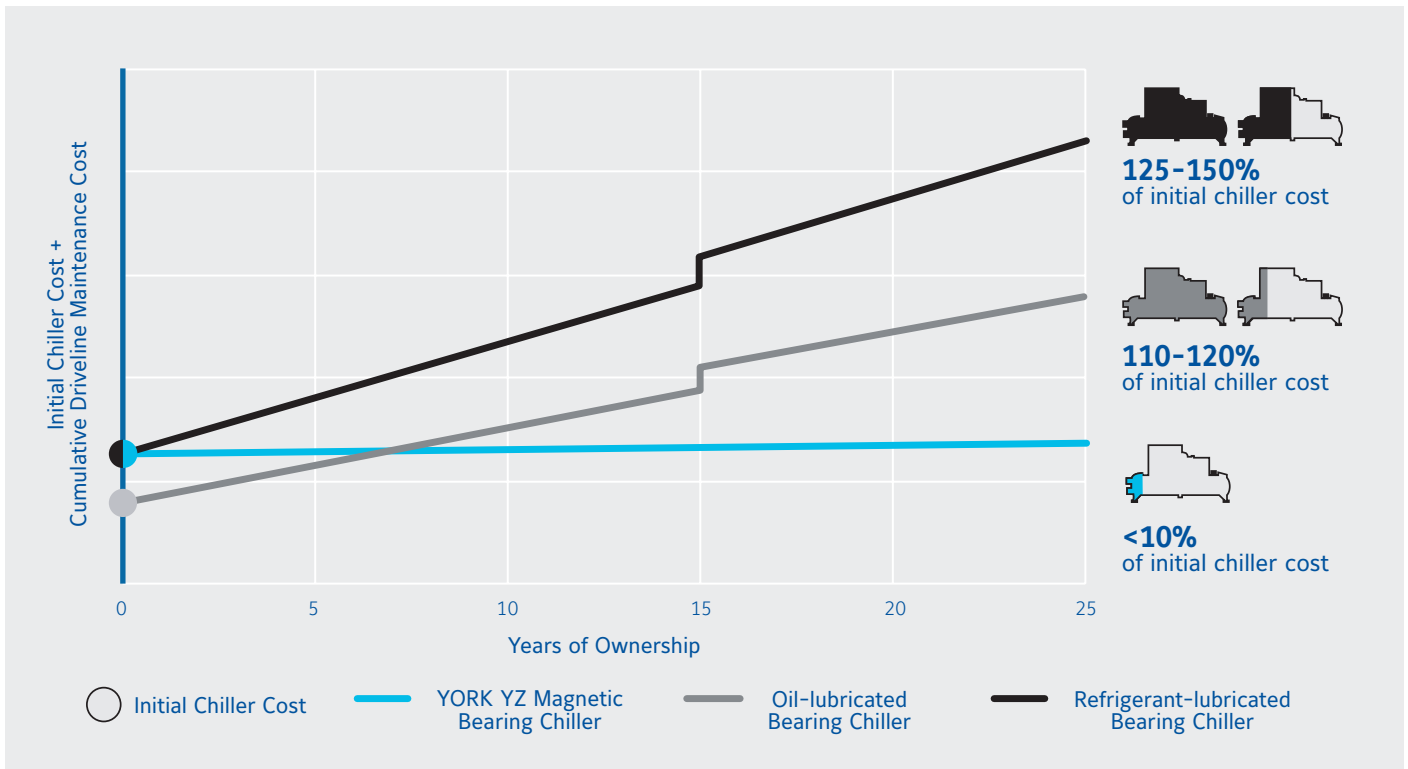

YZ are customized centrifugal units with job specific design. See below table as a reference, within Ecodesign capacity range.

Performances

YZ	900	1100	1300	1500	1600	1800	2000
Cooling capacity (kW)	900	1100	1300	1500	1600	1800	2000
EER	5.99	5.65	6.30	6.00	6.27	6.40	6.10
SEER	8.40	9.00	9.50	9.17	9.00	8.90	9.00
$\eta_{s,c}$ %	333	357	377	364	357	353	357
Sound pressure 1m (dB(A))	74	75	70	78	78	82	83

Ratings in accordance to Ecodesign, fixed water flow and variable outlet (FW/VO). For other Ecodesign calculations please contact your JCI Representative.

The table above shows only a representative sample of performance points based on generic project operating conditions working with R1233zd refrigerant.

For larger capacities up to 5500 kW, contact JCI Representative.

The above data is based on Johnson Controls' selection software Selection Navigator SN24.12. Please refer to the latest version of the software for specific projects.

Technical data

YZ	900	1100	1300	1500	1600	1800	2000
Dimensions	Length	mm	4347	4394	4446	5130	
	Width	mm	1776	1880	2099	2356	
	Height	mm	2244	2375	2515	2594	
Refrigerant charge	kg	230	303	319	364	353	462

1. All dimensions are approximate. Certified dimensions, shipping and operating weights are available on request.

2. Refrigerant charge quantity and unit weight will vary based on tube count.

YMC² Water-cooled magnetic centrifugal chiller

Cooling capacity: 800 kW to 3500 kW (R513A/R134a)

Cooling capacity: 600 kW to 2600 kW (R1234ze/R515B)

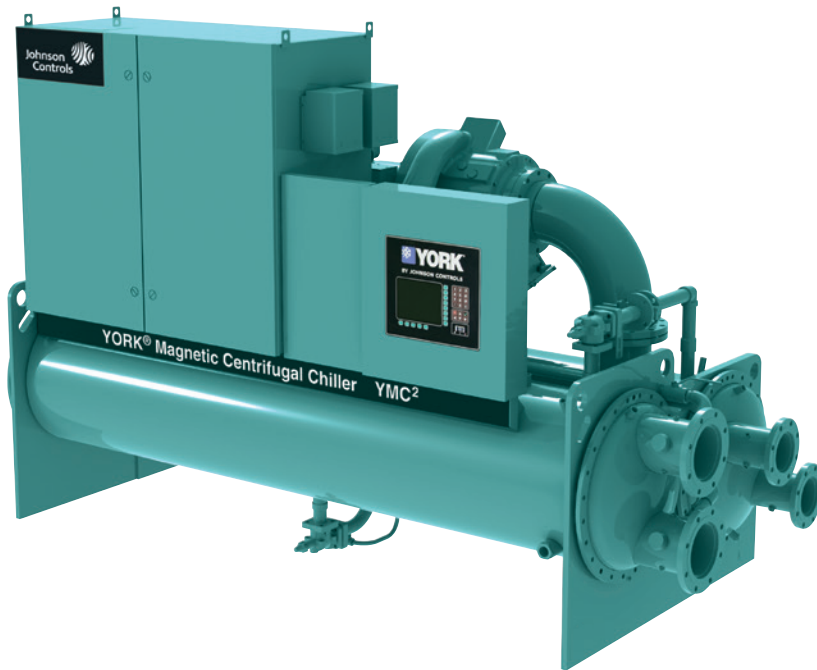

“Tailor and tune”
customized units around
job specific design.

Features

Enhanced efficiency

Achieved through application of active magnetic bearing technology with variable speed drive.

Enhanced sustainability

Achieved by leak free refrigerant design, lower refrigerant charge and falling film evaporator.

Low sound levels

Advanced technology results in sound levels as low as 75dBA.

Superior reliability

Use of active magnetic bearing technology removes friction and the need for oil resulting in a quieter and more reliable chiller.

Superior reliability

Between the centrifugal technologies, this series has the smallest dimensions, fitting where others simply cannot.

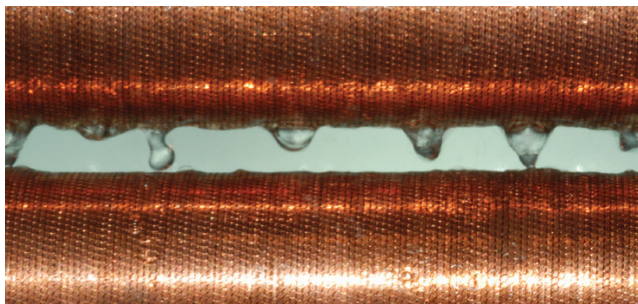

A falling-film evaporator is more efficient because refrigerant is sprayed over the tubes, offering improved heat transfer and reducing refrigerant charge by 30%.

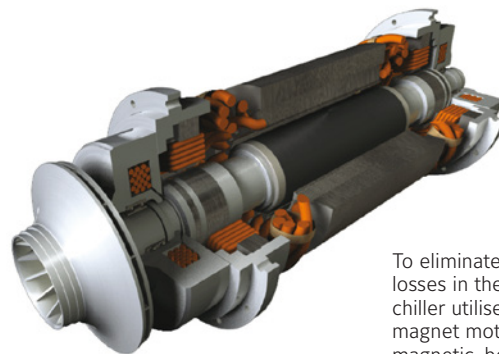

To eliminate mechanical-contact losses in the driveline, the YMC² chiller utilises a permanent-magnet motor and active magnetic-bearing technology.

Water-cooled magnetic centrifugal chiller

YMC² S0800AA to S3500AB



YMC² are customized centrifugal units with job specific design. See below table as a reference, within Ecodesign capacity range.

Performances

YMC ²	S0800AA	S1000AA	S1200AB	S1400AA	S1600AB	S1800AB	S2000AB
Cooling capacity (kW)	800	1000	1200	1400	1600	1800	2000
EER	6.06	6.13	6.32	6.33	6.31	6.07	6.00
SEER	7.58	7.83	7.92	8.34	8.59	7.83	8.16
η _{s, c}	300	310	304	331	340	310	323
Sound pressure at 1 m (dBA)	77	77	76	76	77	79	80

Ratings in accordance to Ecodesign, fixed water flow and fixed outlet (FW/FO). For other Ecodesign calculations please contact your JCI Representative.

The table above shows only a representative sample of performance points based on generic project operating conditions working with R513A refrigerant.

For larger capacities up to 3500 kW or R134a/R515B/R1234ze information, contact your JCI Representative.

The above data is based on Johnson Controls' selection software Selection Navigator SN24.12. Please refer to the latest version of the software for specific projects.

Technical data

YMC ²	S0800AA	S1000AA	S1200AB	S1400AA	S1600AB	S1800AB	S2000AB
Dimensions	Length	mm		3048		4267	
	Width	mm		1880		2007	
	Height	mm		2410		2573	
Shipping weight (kg)	5171		5810		6579		7809
Refrigerant charge (kg)	278	280	423	454	445	612	656

1. All dimensions are approximate. Certified dimensions are available on request.
2. Refrigerant charge quantity and shipping weights will vary based on tube count.
3. Shipping weights are based on fully assembled and charged units.
4. Refer to product drawings for detailed weight information.

Superior sound reduction

A-Weighted sound pressure level (dBA (re: 20μPa))
Measured in accordance with AHRI-575

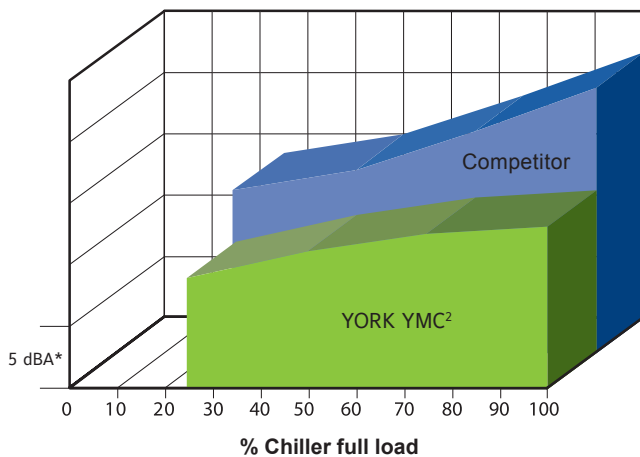

The YMC² chiller is so much quieter than competitive magnetic-bearing chillers, it sounds about half as loud.
*Note: each segment on the Y axis = 5 dBA.

OptiView control centre

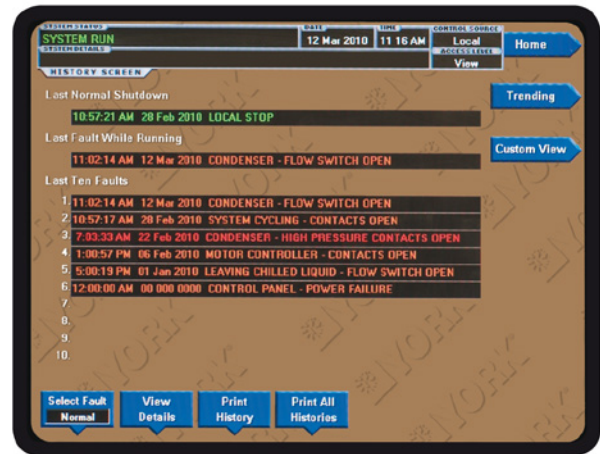

The OptiView control centre provides complete diagnostics to speed troubleshooting.



Manufacturer reserves the rights to change specifications without prior notice.

YK Water-cooled centrifugal chiller

Cooling capacity: 800 kW to 11250 kW (R513A/R134a)

Cooling capacity: 600 kW to 8400 kW (R1234ze/R515B)



“Tailor and tune” customized units around job specific design.

Old but Bold, wondering why?

- Cooling capacity up to approx. 4500 kW with standard 400V VSD; custom made unit can reach 11250 kW.
- 30+ years of experience in the market, with R134a and unit mounted Variable Speed Drive starter.
- The YORK YK chiller is designed for air conditioning and process applications where very high cooling capacities are required, available also with medium voltage supply.
- The high efficiency single-stage centrifugal compressor is powered by an open-drive motor. This provides flexibility to operate the chiller with electricity, steam, or gas depending on utility rates. Lubrication by oil.
- The YK utilizes a falling film evaporator to increase chiller efficiency and reduce refrigerant charges.
- The inherent design flexibility of this chiller allows it to be precisely selected for any building load profile.
- The YK provides the highest flexibility for customization and its small footprint design with R513A make it ideal for retrofit applications too. **Available now with R1234ze refrigerant option for improved sustainability.**



OptiView panel

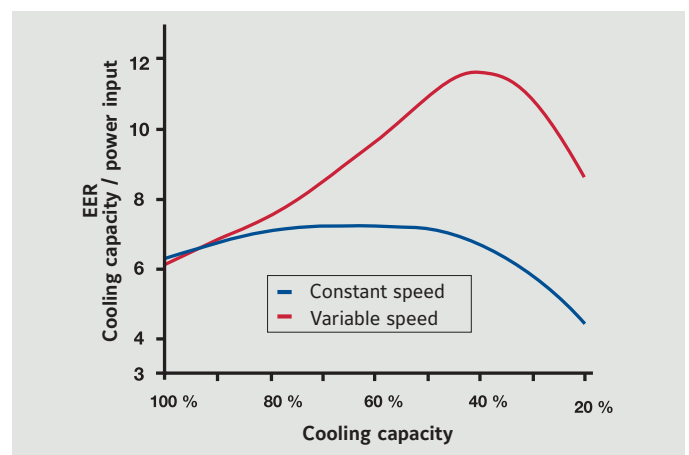

Speed comparison

Refer to <https://www.ahrinet.org/certification/ahri-certification-programs> for water cooled Program Scope, Inclusions, and Exclusions as some options listed herein fall outside the scope of the AHRI certification program. For verification of certification, go to the AHRI Directory at www.ahridirectory.org

Water-cooled centrifugal chiller

YK



YK are customized centrifugal units with job specific design. See below table as a reference.

Nominal capacity

Model	Code	Cooling capacity kW (HFC refrigerants)
YK	Q3 - Q7	800 - 2100
	P7 - P9	1750 - 2800
	H9	2400 - 3800
	K1 - K7	3200 - 9850

Cooling capacities at 7°C leaving chilled water and 30°C entering condensed water. The table above shows only a representative sample of performance points based on generic project operating conditions working with R513A and R134a refrigerants. For R515B or R1234ze information contact your JCI Representative.

Heat Recovery

The YK Heat Recovery option can be used for domestic hot water preheat, process heat, facility air reheat, and humidity control. Heat recovery delivers operational savings, CO2 reductions, and reduced water consumption.



Medium Voltage Variable Speed Drive

YORK has a full line of unit mounted and floor mounted Variable Speed Drives, from 380V to 11,000V, to maximize operational savings at off design conditions; which typically occur 99% of the time!



Quick Start (only available for VSD units)

Utilize Quick Start technology to improve chiller starting times and get back to setpoint up to 70% faster than standard chiller designs!

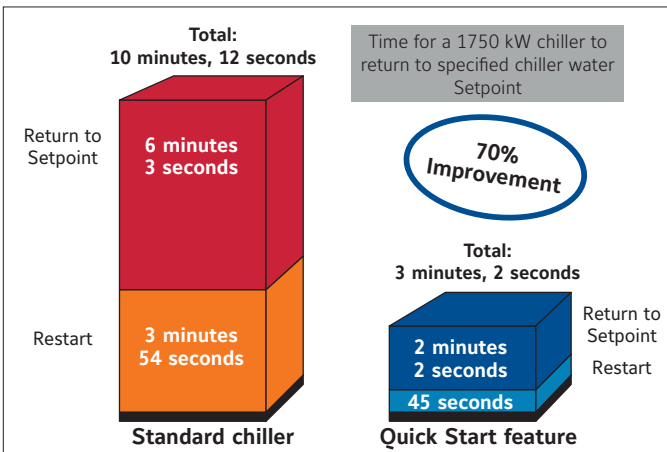

Manufacturer reserves the rights to change specifications without prior notice.

Tailored water-cooled offerings

From 2021 the European market would have to face growing environmental challenges, based on HFC phase down (quota system) and decarbonisation process towards 2050.

YORK is fully ready to support its Customers, introducing now to market new low GWP refrigerant chillers and heat pump solutions to replace boilers or feed large district cooling/heating networks. Connect with your JCI representative for details and support.



YZ
Magnetic bearing centrifugal chiller



Based on the standard YZ range and single stage compressor with 400V supply, the capacity is now up to 5.5 MW to cover larger installations.

YZ works with low GWP new refrigerant R1233zd (GWP = 4.5, F-Gas)



YVWH High Head
Screw compressor with R1234ze



The YVWH water-cooled screw unit offers a solid and robust design for industrial applications.

The YORK screw range has been extended during 2024 with new high head compressors to match dry cooler requirements and high temperature heat pump applications up to 80°C hot water.

Ask how our AHRI certified products can be customized to meet your needs.

YORK is committed to taking on the most unique and complex customer challenges with highly flexible product platforms.



YK

Oil lubricated centrifugal chiller with HFO R1234ze and R515B



The YK water-cooled centrifugal chiller is the most successful unit within YORK water cooled portfolio, with hundreds of installation throughout Europe in the past decades. It offers the highest degrees of flexibility, wide range of capacity and now even includes both R1234ze and R515B refrigerant options for improved sustainability.

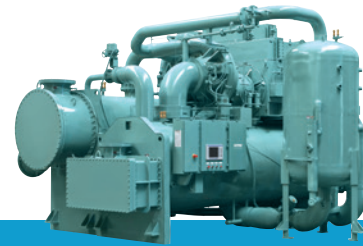

Heat Pumps

Customized temperature settings with both HFC and HFO refrigerants



These are highly engineered products to meet special applications, such as large district heating with special operating temperatures. Key parameters to be taken into account for the unit design are for example:

- Hot water production temperature level (condenser)
- Available source temperature (evaporator)
- Heating capacity target

NOTE: Please refer to specific section of this catalog for custom Heat Pumps offerings and new HFO refrigerants available.

Ask how our AHRI certified products can be customized to meet your needs.

Where there is waste energy,
there is an application for
an absorption chiller.



What are absorption chillers?

- **Employs heat and a concentrated salt solution** (lithium bromide) to produce chilled water.
- **Eliminates ozone depleting, global warming accelerating refrigerants.** Water is the refrigerant, which has zero Global Warming Potential (GWP).
- **Uses the lithium bromide solution's high affinity for water (hygroscopic properties) to create a high vacuum in the evaporator/absorber.** The vacuum causes the refrigerant (water) to boil at 2°C.
- **Absorption refrigeration cycle uses approximately 10% of electricity** compared to an equivalent centrifugal chiller. Very little electricity compared to an electric motor-driven compression cycle chiller.
- **Allows use of a variety of heat sources:** directly using a gas burner, recovering waste heat in the form of low or high temperature hot water, low-pressure or high-pressure steam, exhaust gas, or boiler-generates hot water or steam.
- **Available in flexible configurations.** The easy-to-read control panel can be connected to any building automation system for remote monitoring and control.



YORK® YHAU-CL-DXS single-effect absorption chiller's two-step design backed with an auxiliary cycle provides a wide operating envelope utilizing waste heat as low as 55°C where competitive offerings cannot operate.

YORK® YHAU-CW double-effect design combines the flexibility of a wide operating envelope with the efficiency and reliability made possible by today's advanced technology. The innovative YHAU-CW design is optimally suited for a variety of steam pressures that are commonly found in combined heat and power (CHP) systems, and commercial cooling and industrial process applications.



Applying absorption chillers

Reusing Waste Energy for Cooling and Comfort



Industry
Petroleum and Chemical

Driving Heat Source
Uses heat from desalting and distillation (fractionation) processes

Energy
Waste Heat

Application and Chiller Selection
For hot water or low-pressure steam: [YHAU-CL/CH](#) & [YHAU-C](#)
For direct firing or high-pressure steam: [YHAU-CG](#) & [YHAU-CW](#)



Industry
Brewery

Driving Heat Source
Uses heat recovered from cookers and kettles

Energy
Waste Heat

Application and Chiller Selection
For hot water or low-pressure steam: [YHAU-CL/CH](#) & [YHAU-C](#) & [YHAU-L](#) & [YHAU-LL](#)



Industry
Printing

Driving Heat Source
Uses heat recovered from press drying units

Energy
Hot Air

Application and Chiller Selection
For hot water: [YHAU-CL/CH](#) & [YHAU-CHW](#)



Industry
Pulp and Paper Mill

Driving Heat Source
Uses heat from the combustion of bark and lignin

Energy
Steam

Application and Chiller Selection
For low-pressure steam: [YHAU-C](#)
For high-pressure steam: [YHAU-CW](#)



Industry
District Cooling

Driving Heat Source
Uses low- and high-pressure district steam

Energy
Steam

Application and Chiller Selection
For low-pressure steam: [YHAU-C](#)
For high-pressure steam: [YHAU-CW](#)

APPLICATION OPPORTUNITIES
FOR ABSORPTION CHILLERS



Industry
Incinerator

Driving Heat Source
Uses recovered heat from hot exhaust

Energy
Hot Exhaust

Application and Chiller Selection
For hot water or low-pressure steam: [YHAU-CL/CH](#) & [YHAU-C](#)



Industry
Landfill Gas

Driving Heat Source
Uses heat from methane gas burners or methane-fired boilers

Energy
Gas

Application and Chiller Selection
For hot water or low-pressure steam: [YHAU-CL/CH](#) & [YHAU-C](#)
For direct firing: [YHAU-CG](#) & [YHAU-CE](#)



Industry
Biogas

Driving Heat Source
Uses heat from methane gas burners or methane-fired boilers

Energy
Gas

Application and Chiller Selection
For hot water or low-pressure steam: [YHAU-CL/CH](#) & [YHAU-C](#)
For direct firing: [YHAU-CG](#) & [YHAU-CE](#)



Industry
Combined Heat and Power

Driving Heat Source
Uses heat recovered from exhaust gas and/or engine coolant

Energy
Hot Exhaust; Hot Water

Application and Chiller Selection
For hot water or low-pressure steam: [YHAU-CL/CH](#) & [YHAU-DXS](#) & [YHAU-C](#)
For high-pressure steam: [YHAU-CW](#) & [YHAU-CHW](#)



Industry
Solar Thermal

Driving Heat Source
Uses a solar panel array as a sustainable energy source

Energy
Hot Water

Application and Chiller Selection
For hot water: [YHAU-CL/CH](#)





YORK absorption chillers and heat pumps

With innovative 2-step evaporation and absorption-cycle technology

Driving Heat Source	Model and Description
<p>Hot Water, Steam, Direct Fired</p>	<p>Absorption Heat Pump (Up to 95°C) Model: YHAP Capacity: Custom Application: District heating, industrial process heating</p> 
<p>Hot Water</p>	<p>Single Effect Hot Water Model: YHAU-CL/CH & CL/CH-B Capacity: 105 - 6,350 kW Application: Combined heat and power (CHP), commercial cooling, industrial process cooling</p> 
<p>Low Temperature Hot Water</p>	<p>Single Effect Double Lift Hot Water Model: YHAU-CL/CH-DXS Capacity: 176 - 2,813 kW Application: Combined heat and power (CHP), commercial cooling, industrial process cooling</p> 
<p>Low Pressure Steam</p>	<p>Single Effect Steam Model: YHAU-C & C-B Capacity: 205 - 5,275 kW Application: Combined heat and power (CHP), commercial cooling, industrial process cooling</p> 
<p>High and Medium Pressure Steam</p>	<p>Double Effect Steam Model: YHAU-CW & CW-B Capacity: 422 - 14,067 kW Application: Combined heat and power (CHP), commercial cooling, industrial process cooling</p> 

YORK absorption chillers and heat pumps

With innovative 2-step evaporation and absorption-cycle technology

Driving Heat Source	Model and Description
<p>Small Direct Fired</p>	<p>Small Double Effect Natural Gas or Light Oil * Model: YHAU-CG/CA-CXR Capacity: 105 - 352 kW Application: Commercial cooling</p> 
<p>Direct Fired</p>	<p>Large Double Effect Natural Gas or Light Oil Model: YHAU-CG/CA & CG/CA -B Capacity: 422 - 5,626 kW Application: Commercial cooling, industrial process cooling</p> 
<p>Natural Gas and Low Temperature Hot Water</p>	<p>Gas Gene-Link Model: YHAU-CG-J Capacity: 422 - 5,626 kW Application: Combined heat and power (CHP), commercial cooling, industrial process cooling</p> 
<p>Medium Pressure Steam and Low Temperature Hot Water</p>	<p>Steam Gene-Link Model: YHAU-CW-J Capacity: 422 - 14,067 kW Application: Combined heat and power (CHP), industrial process cooling</p> 

* Utilizes standard cycle

The 2-step cycle in YORK absorption chillers

Reliable energy-saving technology, explained.

Conventional Cycle

Another way of thinking about this process is to imagine a rocket ship trying to reach the moon.

In the example here, the rocket ship only has one rocket to push it the entire distance from the earth to the moon – requiring 100% of the fuel. In much the same way, a conventional-cycle absorption chiller only has one evaporator and absorber to overcome cooling output requirements and achieve the cooling load, using 100% input energy.



2-Step Evaporator/Absorber Cycle

Now imagine the rocket ship has two rockets to share the goal of reaching the moon.

Both rockets need less fuel, since they share the effort to get the rocket ship to its goal. Instead of a single rocket bearing the entire job from point A to point B, two rockets split the effort, allowing for a continuation of effective effort and requiring only 90% of the fuel. This example illustrates the 2-step evaporator/absorber cycle, which allows the evaporator and absorber to achieve the necessary cooling output over two steps while using 10% less input energy.

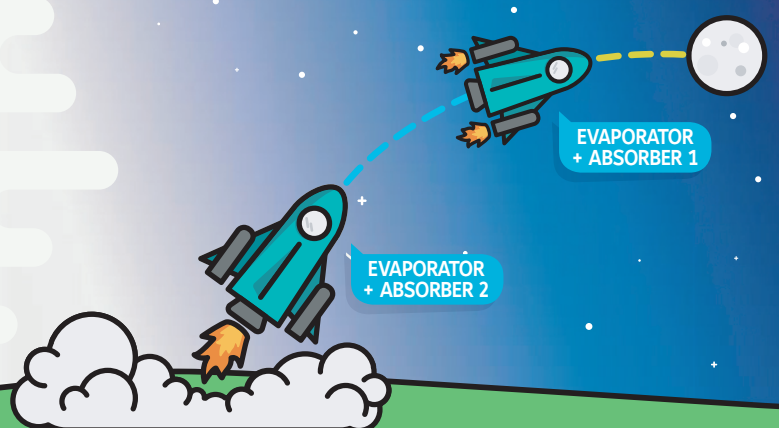

The 2-step cycle evaporator/absorber requires less energy input and a lower salt solution concentration, allowing for increased reliability and 10% energy savings.

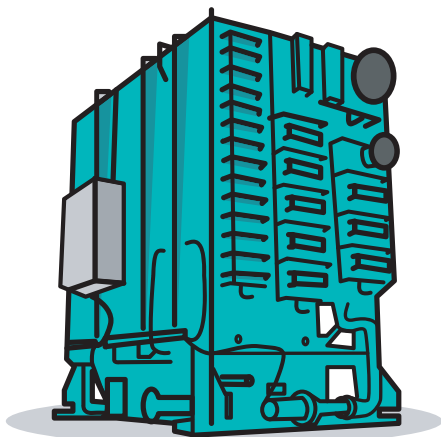

Input Energy Required to Achieve Cooling Load

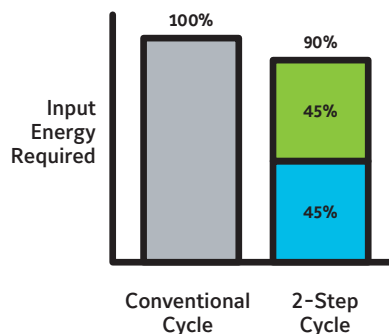

Salt Solution Concentration

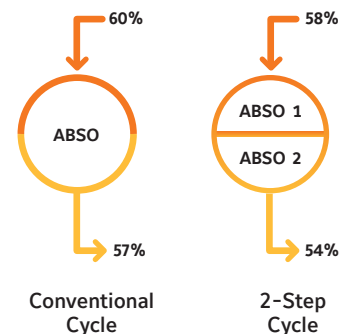

Learn more about the benefits of YORK 2-step cycle technology at YORK.com/Absorption-Chillers

YORK parallel flow and 2-step cycle absorption chiller technology

A challenge in absorption chiller design is engineering a unit that operates furthest from the crystallization line. Johnson Controls absorption engineers accepted the challenge with the development of a parallel flow and 2-step evaporator/absorber design technology.

Typical Industry Flow Cycles

Parallel

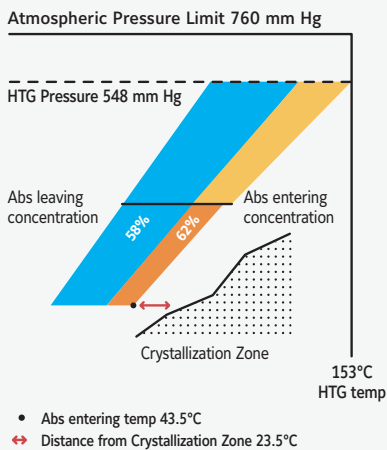
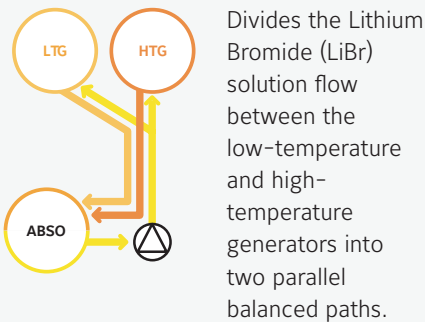

Series

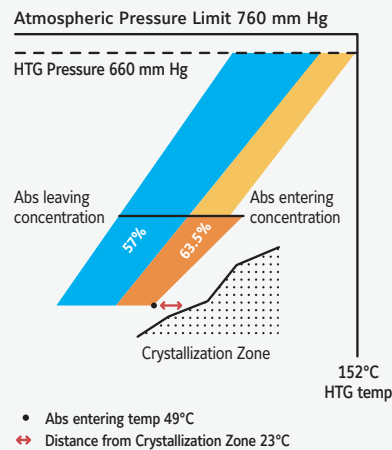
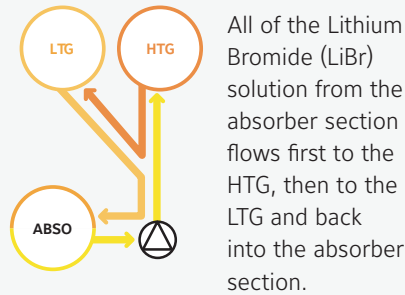

Reverse

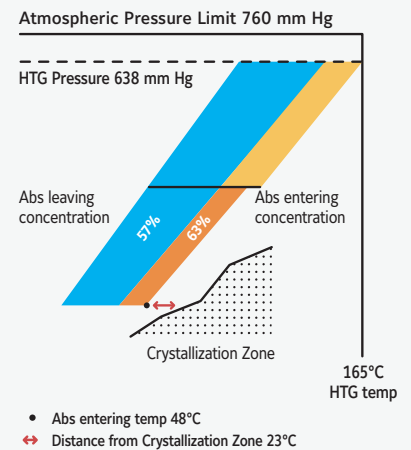
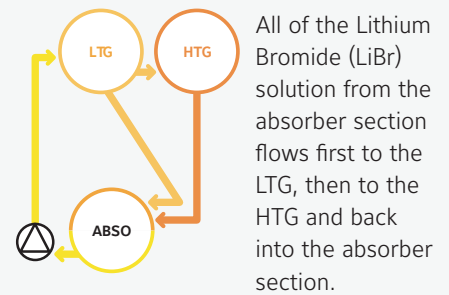

Benefit of Combined Parallel Flow and 2-Step Evaporator/Absorber Technology

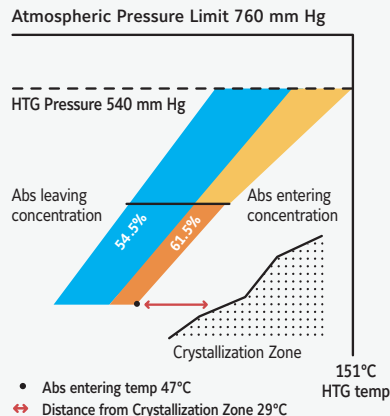
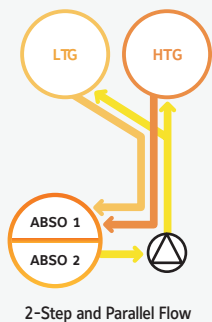

Combining these two technologies, our two-step and parallel flow design provides the lowest temperature, pressure and concentration. Because this design uses a lower LiBr concentration, it is easier to heat in the generator section. Therefore, it requires a relatively lower grade for the driving heat source, providing a high COP.

YORK parallel flow and 2-step absorption chiller technology operates furthest from the crystallization zone for efficient and reliable operation compared to other designs.

Conditions: Chilled water entering/leaving: 12°C/7°C. Cooling water entering: 32°C.
"Absorption Chillers - Practice of new operation management" - 2nd Edition, published by JRAIA, 2017

YHAP

Absorption heat pump

Custom capacities from 1 MW to 40 MW

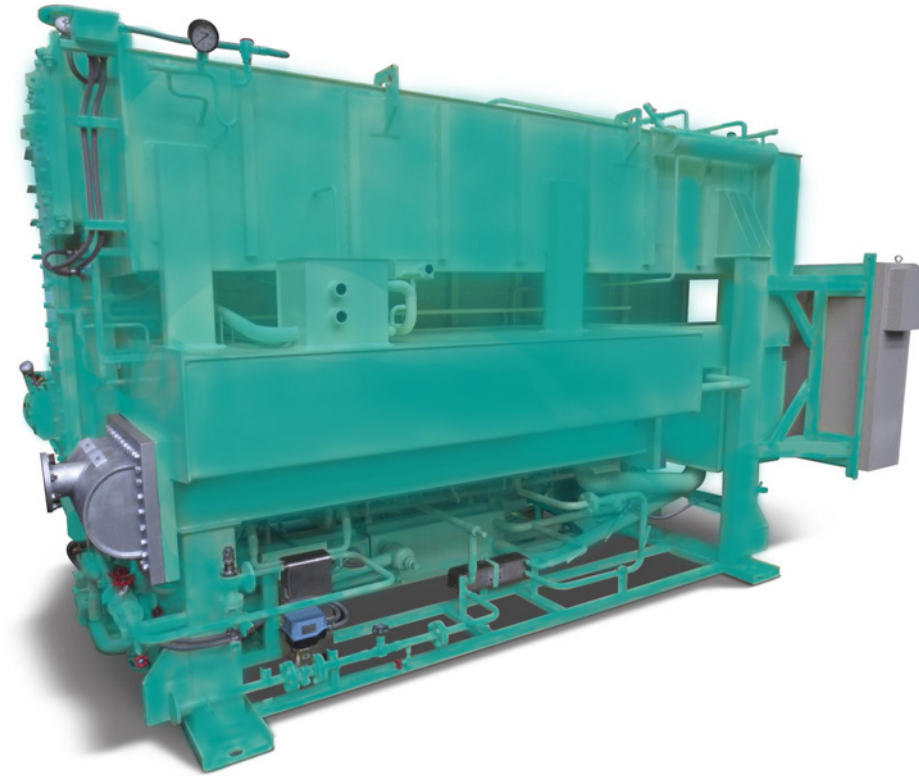

Achieves highest energy and water savings while helping reduce CO₂ emissions

The **YORK® YHAP** absorption heat pump saves energy by transferring heat (energy) from waste heat sources to increase the temperature of supplied hot water. The additional heat (energy) required by a heat pump system is far less than needed by a boiler.

YHAP absorption heat pumps are ideal for district heating and industrial process heating applications, because they take advantage of waste heat energy found in industrial facilities and deliver high-temperature hot water.

Maximizing performance by design

Driving heat sources: **YORK®** absorption heat pumps use a variety of driving heat sources, such as jacket water from a gas engine, low to high pressure steam, direct fired or even exhaust gas. As a result, the unit helps reduce primary energy consumption, water and carbon dioxide emissions. The **YHAP** design is also more efficient and reliable than conventional designs, because it employs innovative, 2-step evaporation and absorption technology.

To meet the needs of different heating applications, two types of **YHAP** absorption heat pumps are available:

Type I heat pump, also referred to as a heat amplifier, is driven by a high-temperature driving heat source in the generator section.

Type II heat pump, also referred to as the heat transformer, is driven by a medium-temperature driving heat source in the generator and evaporator sections.

Two Types of YHAP Heat Pumps

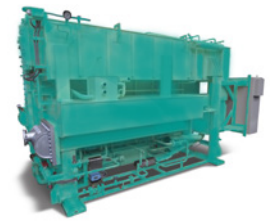

Type I

Driven by high-temperature driving heat source in generator

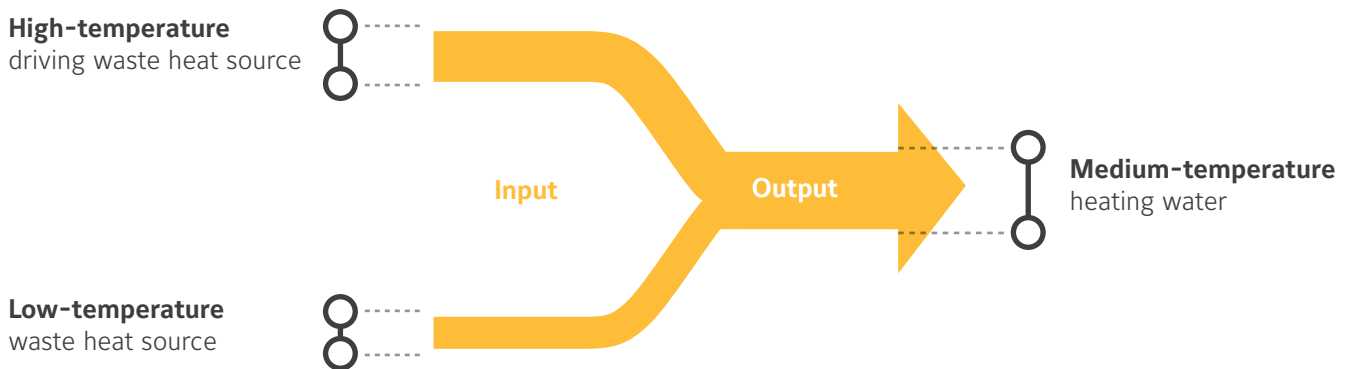

Type II

Driven by medium-temperature driving heat source in generator and evaporator

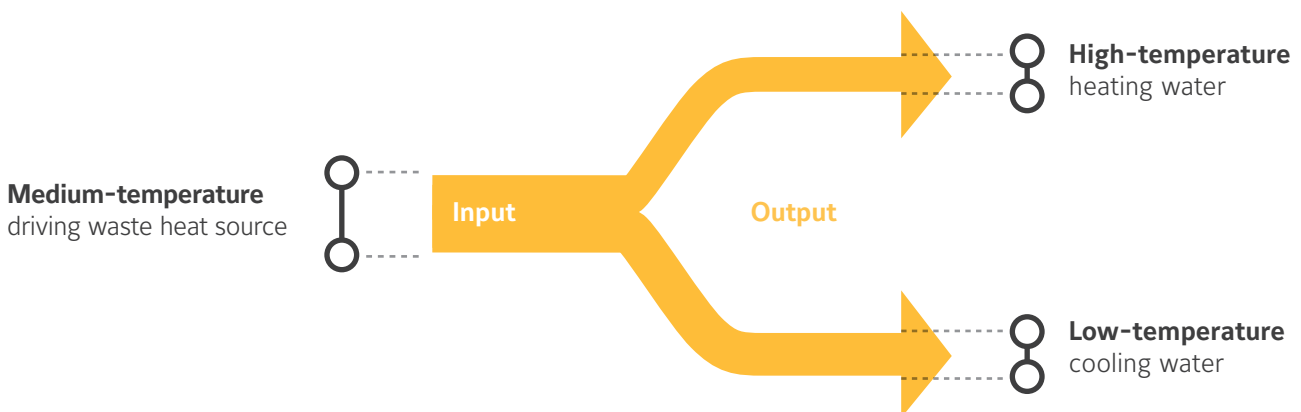

Type I Flexible Operating Envelope

The Type I heat pump, also referred to as a heat amplifier, is driven by a high-temperature waste heat source in the generator section. The low-temperature waste heat source is fed into the evaporator section. With these two heat sources, the Type I heat pump amplifies and provides useful medium temperature heat from the absorber and condenser section.

How it Works

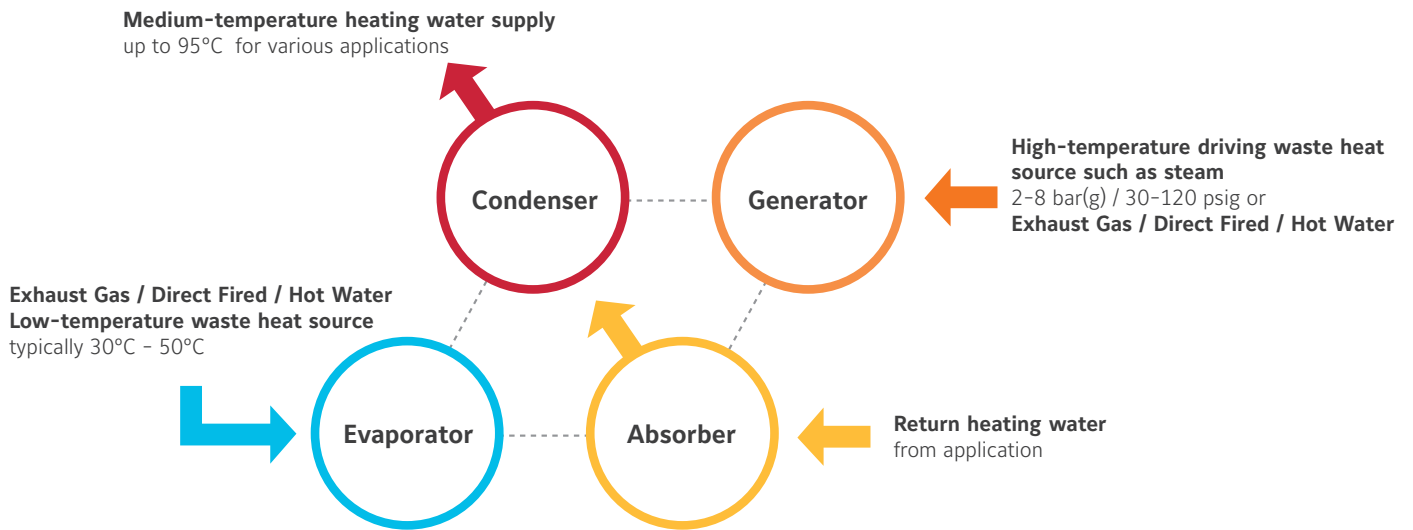

Heat Balance

Compared to the typical steam boiler's 0.93 Coefficient of Performance (COP), the Type I unit provides a COP as high as 1.7*, delivering up to 95°C hot water for various heating applications. This unit also provides a good turndown over a range of heating loads.

Performance of Boiler Compared to Absorption Heat Pump

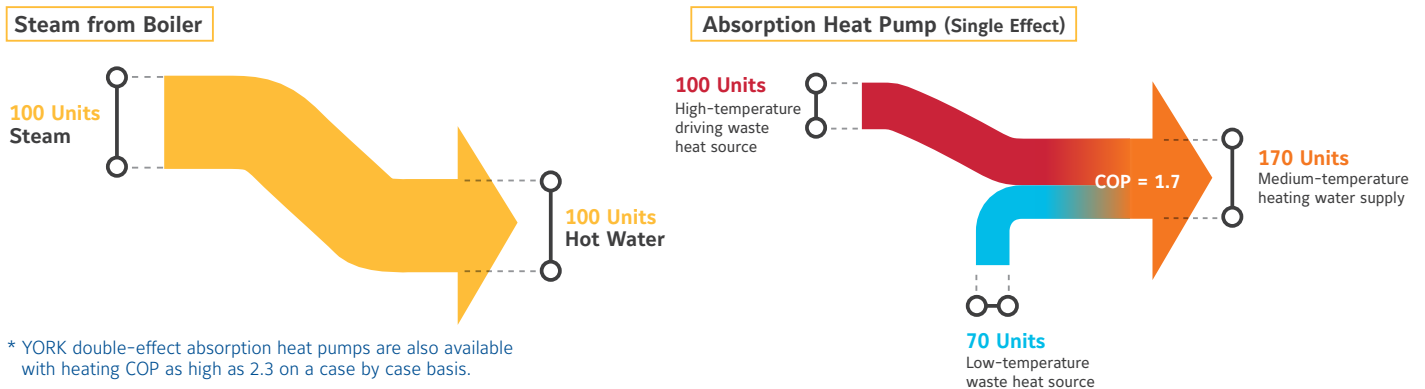

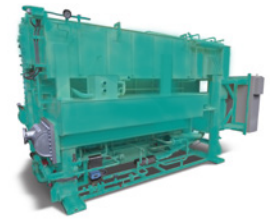

Type I Industrial Application

The Type I unit produces a high amount of medium-temperature heat from the absorber and condenser section based on a relatively smaller amount of high-temperature waste heat in the generator section and low-temperature waste heat in the evaporator section.

In this Type I application, the extracted steam at 0.5 MPa(g) from the power steam turbine is the driving heat source in the generator section. The water diverted from the cooling tower is the low-temperature waste heat source that is fed into the evaporator section. The heat pump delivers 90°C from the

absorber and condenser section, which can be used for district heating or boiler feed water pre-heating. This application saves primary energy, reduces steam and water consumption and helps cut emissions.

With a Type I absorption heat pump, it is typical to have a heating COP of 1.7, meaning 1.7 units of heat is obtained from the absorber and condenser with a 1.0 unit of driving heat source in the generator and .7 units being in the evaporator section.

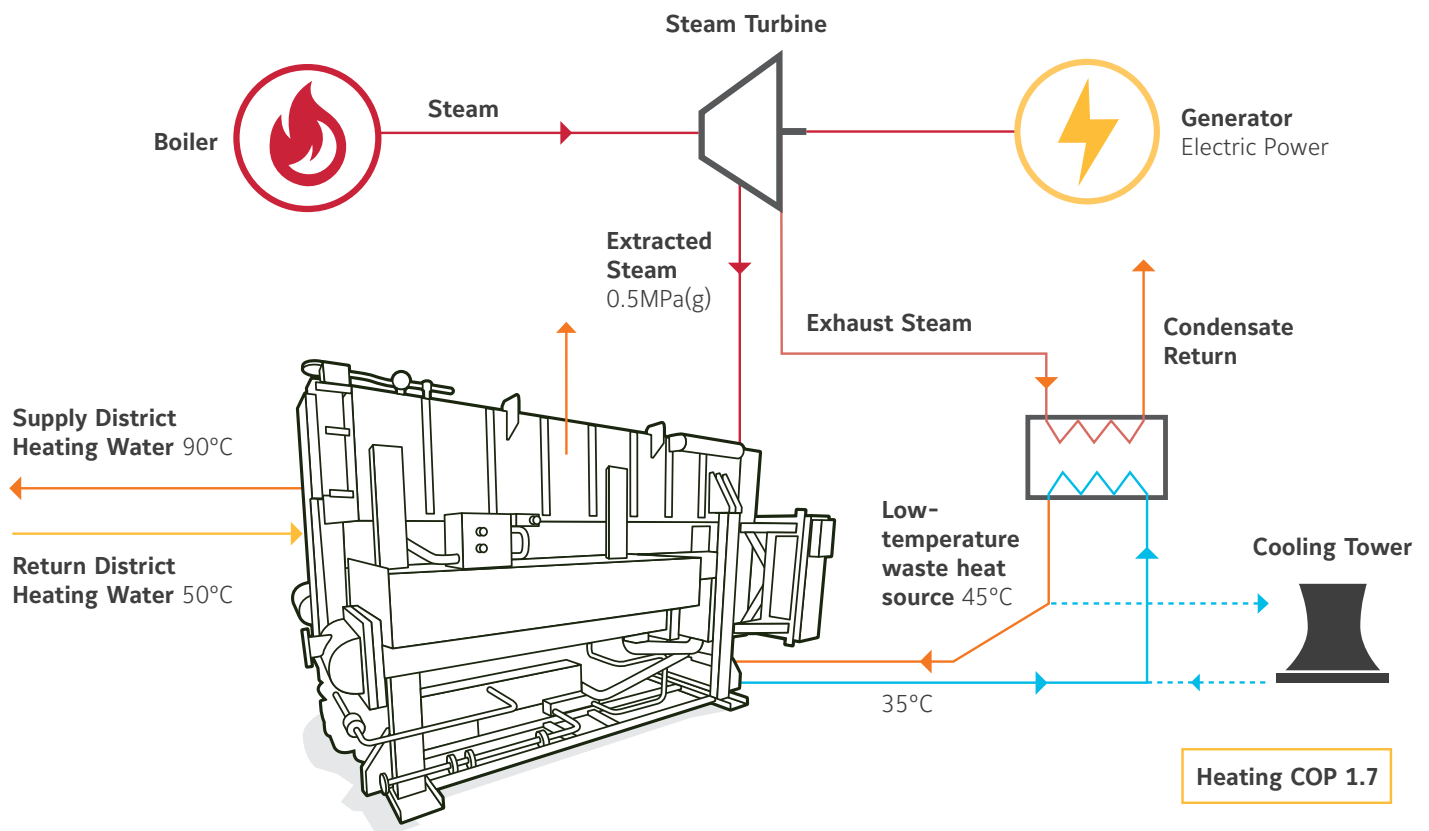

Type II Flexible Operating Envelope

The Type II heat pump, also referred to as a heat transformer, is driven by a medium-temperature waste heat source in the generator and evaporator sections. This unit transforms and provides small, useful high-temperature heat from the absorber section. The rejected heat from the condenser can be used as the cooling water for other applications.

How it Works

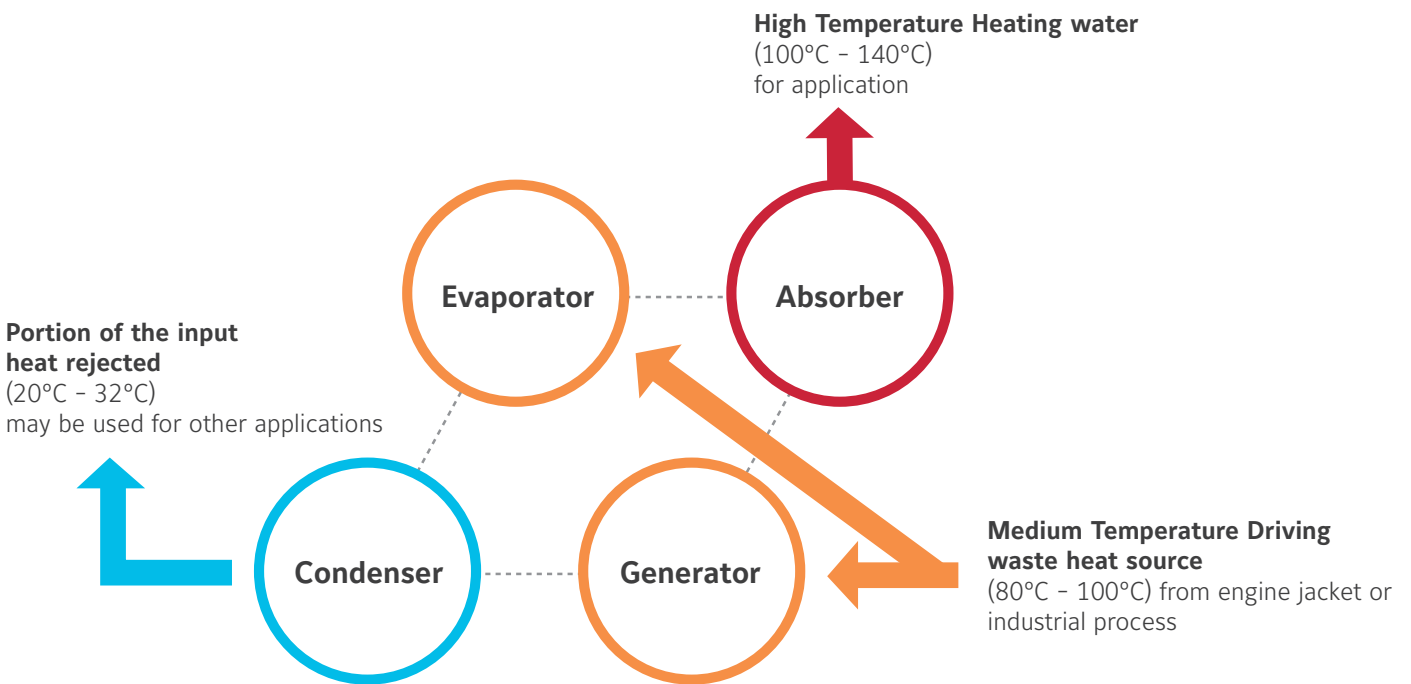

Heat Balance

The Type II heat pump with a COP of 0.47 can deliver high-temperature hot water up to 140°C, which is ideal for industrial processes. This unit also provides a good turndown over a range of heating loads.

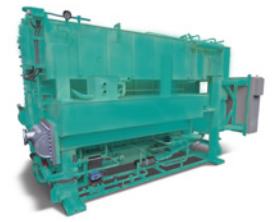

Type II Industry Application Process Heating Application

With a Type II absorption heat pump, it is typical to have a heating COP of 0.47, meaning 0.47 units of heat is obtained from the absorber with a 1.0 unit of driving heat source in the evaporator and generator. The 0.53 units of heat rejected in the condenser can be used for other process applications.

In this Type II absorption heat pump application, the jacket water of the gas engine at 90°C is the driving heat source. The heat pump delivers 137°C from the absorber section that can be flashed in a tank to produce low-pressure steam at 0.2 MPa(g) / 30 psig for process heating. A portion of the input heat is rejected through the condenser section and is used for other purposes in the facility.

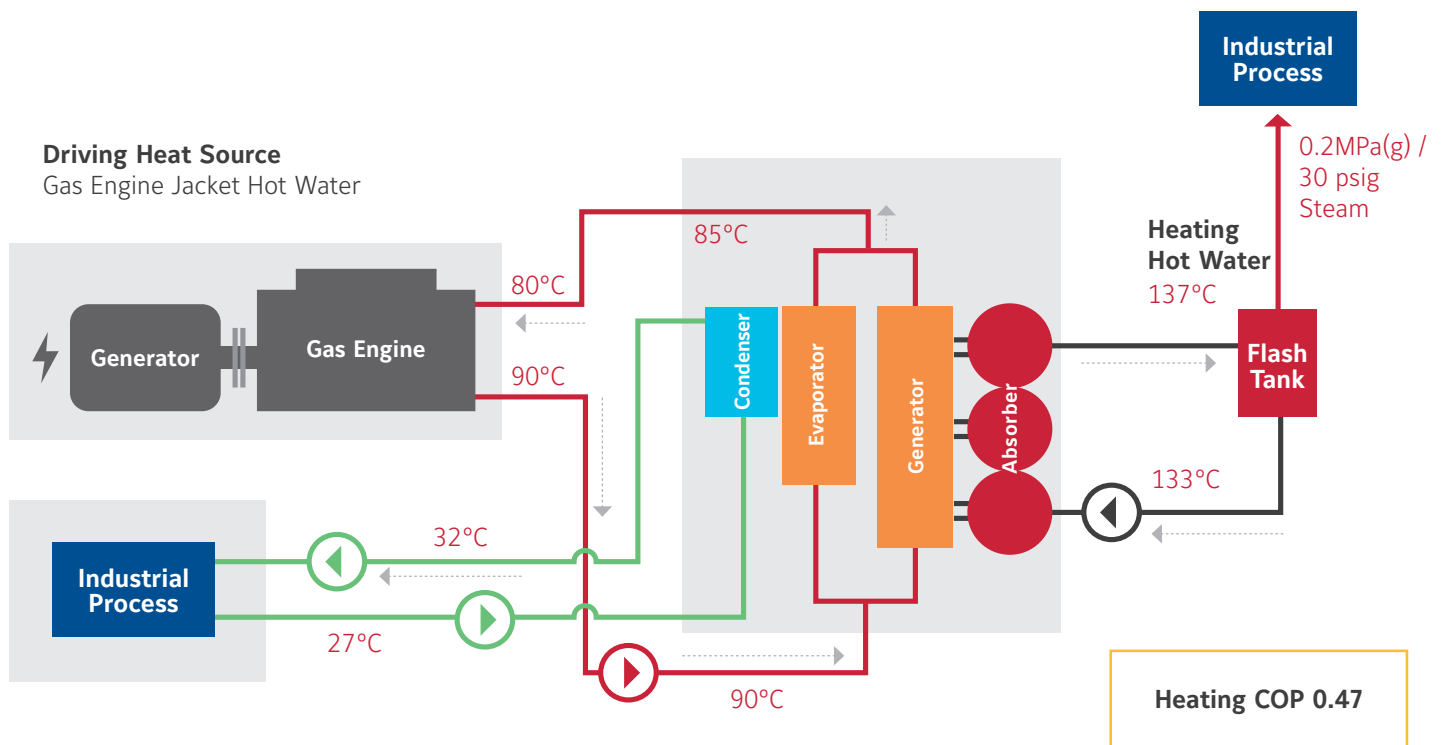

YHAU-CL/CH

Single Effect hot water driven absorption chiller

Cooling capacities from 105 kW to 6350 kW



Features

Flexible Operating Envelope

The **YORK YHAU-CL/CH** Single Effect Hot Water absorption chiller provides efficiency and reliability through the use of innovative technology that is optimized to use low temperature waste heat – as low as 70°C where competitive offerings cannot operate. Common applications include comfort or industrial process cooling that use or recover waste heat from combined heat and power (CHP) systems, industrial process or other available heat sources. The **YHAU-CL/CH** cooling capacity ranges from 105–6,350 kW.

The **YHAU-CL/CH** has the unique ability to be used for applications where the

- Chilled water leaving temperature as low as 1°C.
- Cooling water temperature entering temperature as high as 37°C.
- Hot water temperature, driving heat source, entering temperature as high as 160°C and as low as 70°C.

Refrigerant cycle

The **YORK YHAU-CL/CH** high efficiency single-effect absorption refrigeration cycle uses water as the refrigerant and lithium bromide as the absorbent. It is the strong affinity and ease of separation that these two substances have for each other that makes the cycle work. The entire process occurs in hermetic vessels in a near complete vacuum.

Single Effect hot water driven absorption chiller

YHAU-CL/CH



Two Step Evaporator and Absorber Design

Efficiency, Reliability, Cost of Ownership

The innovative 2-step evaporator and absorber design is more efficient than a conventional cycle. This ingenious design splits the absorption process into two steps, similar to how a series-counter-flow arrangement splits the work between two chillers. The result of the design allows the **YHAU-CL/CH** to perform the absorption function with lower solution concentrations than conventional designs, increasing efficiency and reliability, and decreasing cost of ownership.

Reliability is enhanced because the solution concentrations are lower leaving the absorber, which allows the entire cycle to operate at lower concentrations virtually eliminating the possibility of crystallization. Efficiency is enhanced because the **YHAU-CL/CH** can take advantage of lower than normal hot water temperatures in the generator. This is because at lower concentrations the solution will boil at a lower temperature in the generator.

Lastly, total operating cost decreases because of the lower concentration of the solution entering the generator, a wider temperature range of hot water can be used, reducing pumping horsepower.

Nominal capacity

YHAU-CL/CH model	30EXE	40EXE	50EXE	65EXE	80EXE	100EXE	130EXE	160EXE	200EXE	255EXE	320EXE	400EXE	500EXE
Cooling Capacity kW	105	141	179	222	271	352	443	563	721	869	1125	1407	1758
COP (low temp. hot water)	0.78	0.78	0.78	0.78	0.78	0.76	0.78	0.78	0.78	0.78	0.78	0.78	0.78

YHAU-CL/CH model	630EXW2S	700EXW2S	800EXW2S	900EXW2S	1000EXW2S	1120EXW4S	1250EXW4S	1400EXW4S	1500EXW4S	1600EXW4S	1680EXW4S	1800EXW4S	1900EXW4S	2000EXW4S
Cooling Capacity kW	1934	2110	2461	2708	3024	3411	3938	4431	4852	5134	5274	5650	5960	6350
COP (low temp. hot water)	0.78	0.78	0.78	0.78	0.78	0.78	0.78	0.78	0.78	0.78	0.78	0.78	0.78	0.78

At 6°C leaving chilled water, 90°C entering generator water, and 27°C entering condenser water.

Technical data

YHAU-CL model		30EXE	40EXE	50EXE	65EXE	80EXE	100EXE	130EXE	160EXE	200EXE	255EXE	320EXE	400EXE	500EXE	
Dimensions	Length mm	1750	2100	2500	3050	2200	2600	3150	3800	4600	3250	3900	4700	5700	
	Width mm	1550							1900			2350			
	Height mm	2100							2500			3200			
Operating weight kg		2900	3300	3800	4400	4700	5500	6500	7800	9100	11300	13300	15500	18600	

YHAU-CL model		630EXW2S	700EXW2S	800EXW2S	900EXW2S	1000EXW2S	1120EXW4S	1250EXW4S	1400EXW4S	1500EXW4S	1600EXW4S	1680EXW4S	1800EXW4S	1900EXW4S	2000EXW4S
Dimensions	Length mm	5500	6000	6700	7300	8000	6800	7600	8200	8700	9200	9700	10200	10700	11200
	Width mm	2750										3300			
	Height mm	3300										3900			
Operating weight kg		22800	24600	26500	29300	31700	43900	46300	48700	50900	53200	55400	58100	60900	63600

YHAU-CH model		30EXE	40EXE	50EXE	65EXE	80EXE	100EXE	130EXE	160EXE	200EXE	255EXE	320EXE	400EXE	500EXE	
Dimensions	Length mm	1900	2250	2650	3200	2350	2750	3300	3950	4750	3400	4050	4850	5850	
	Width mm	1550							1900			2350			
	Height mm	2100							2500			3200			
Operating weight kg		3500	3900	4400	5000	5800	6600	7600	8900	10200	13700	15700	17900	21000	

YHAU-CH model		630EXW2S	700EXW2S	800EXW2S	900EXW2S	1000EXW2S	1120EXW4S	1250EXW4S	1400EXW4S	1500EXW4S	1600EXW4S	1680EXW4S	1800EXW4S	1900EXW4S	2000EXW4S
Dimensions	Length mm	5500	6000	6700	7300	8000	6800	7600	8200	8700	9200	9700	10200	10700	11200
	Width mm	2750										3300			
	Height mm	3300										3900			
Operating weight kg		25400	27200	29100	31900	34300	47600	50000	52400	54600	56900	59100	61800	64600	67300



Manufacturer reserves the rights to change specifications without prior notice.

YHAU-CL/CH-DXS

Single Effect Double Lift Hot Water Driven Absorption Chiller

Cooling capacities from 176 kW to 2813 kW



Features

Flexible Operating Envelope

The **YORK YHAU-CL/CH-DXS** Single Effect Double Lift Hot Water absorption chiller provides efficiency through the use of innovative technology. It is optimized to use low temperature waste heat – as low as 55°C where competitive offerings cannot operate. Common applications include comfort or industrial process cooling that use or recover waste heat from combined heat and power (CHP) systems, districts heating systems, industrial process or other available heat sources. The **YHAU-CL/CH-DXS** cooling capacity ranges from 176-2,813 kW.

The **YHAU-CL/CH-DXS** has the unique ability to be used for applications where the

- Chilled water leaving temperature as low as 1°C.
- Cooling water temperature entering temperature as high as 37°C.
- Hot water temperature, driving heat source, entering temperature as high as 160°C and as low as 55°C.
- Hot water leaving temperature as low as 40°C.

Refrigerant cycle

The **YORK YHAU-CL/CH-DXS** high efficiency single-effect double lift absorption refrigeration cycle uses water as the refrigerant and lithium bromide as the absorbent. It is the strong affinity and ease of separation that these two substances have for each other that makes the cycle work. The entire process occurs in hermetic vessels in a near complete vacuum.

Single Effect Double Lift Hot Water Driven Absorption Chiller

YHAU-CL/CH-DXS



Parallel Flow and Two Step Evaporator and Absorber Design

Efficiency, Reliability, Cost of Ownership

The innovative 2-step evaporator and absorber design is more efficient than a conventional cycle. This ingenious design splits the absorption process into two steps, similar to how a series-counter-flow arrangement splits the work between two chillers.

Parallel flow divides the LiBr solution flow between the low- and high- temperature generators into two parallel, balanced paths. One goes to the high temperature generator (HTG), while the other goes to the low temperature generator (LTG).

The result of the design allows the **YHAU-CL/CH-DXS** to perform the absorption function with lower solution concentrations than conventional designs, increasing efficiency and reliability, and decreasing cost of ownership.

Reliability is enhanced because the solution concentrations are lower leaving the absorber, which allows the entire cycle to operate at lower concentrations virtually eliminating the possibility of crystallization. Efficiency is enhanced because the **YHAU-CL/CH-DXS** can take advantage of lower than normal hot water temperatures in the generator. This is because at lower concentrations the solution will boil at a lower temperature in the generator.

Lastly, total operating cost decreases because of the lower concentration of the solution entering the generator, a wider temperature range of hot water can be used, reducing pumping horsepower.

Full Automatic Purging System

As a standard feature, the unit has a fully automatic purging system comprising of electronic vacuum transmitter, solenoid valves and trending capability that ensures design performance and improves reliability. The operator does not have to worry about the sequence of purging for removing the non-condensable gases.

Chiller control

The **YHAU Control Center**, standard on each chiller, provides the ultimate in efficiency, monitoring, data recording, chiller protection and operating ease.

The LCD display allows graphic animated display of the chiller, chiller sub-systems and system parameters; this allows the presentation of several operating parameters at once. In addition, the operator may view a graphical representation of the historical operation of the chiller as well as the present operation. The panel is capable of communication with building management systems and is available in multiple languages.

Nominal capacity

YHAU-CL/CH-DXS Model	50DXS	60DXS	80DXS	100DXS	130DXS	160DXS	200DXS	250DXS	320DXS	400DXS	500DXS	600DXS	700DXS	800DXS
Cooling Capacity kW	176	211	281	352	457	563	703	897	1125	1406	1758	2110	2461	2813
COP (low temp. hot water)	0.72	0.72	0.72	0.72	0.72	0.72	0.72	0.72	0.72	0.72	0.72	0.72	0.72	0.72

At 7°C leaving chilled water, 95°C entering generator water, and 27°C entering condenser water.

Technical data

YHAU-CL/CH-DXS Model	50DXS	60DXS	80DXS	100DXS	130DXS	160DXS	200DXS	250DXS	320DXS	400DXS	500DXS	600DXS	700DXS	800DXS		
Dimensions	Length	mm	1900	2200	2600	3200	3900	2700	3300	4000	4800	5800	5400	6200	7200	7900
	Width	mm	2100		2200		2500		2600		3000					
	Height	mm	2700			3000			3300							
Operating weight	kg	8300	8900	9800	11100	12500	14600	16500	18700	22200	25600	31900	35900	40700	43700	



Manufacturer reserves the rights to change specifications without prior notice.

YHAU-CL/CH-B

Single Effect hot water driven absorption chiller (Mod B)

Cooling capacities from 703 kW to 3516 kW



Advancing efficiency by design

The YORK® YHAU-CL/CH-B Single-Effect Hot Water Absorption Chiller uses an innovative two-step evaporator and absorber cycle that is more efficient than conventional cycles. By splitting the absorption process into two steps, lithium-bromide solution concentrations are lower in the system, resulting in:



Higher system efficiency: Lower source hot-water temperature into the generator can be used to drive the absorption cycle.



Superior reliability: Virtually eliminates crystallization risk and reduces the potential for corrosion.



Lower total operating cost: Can operate with lower hot water flow rates and reduced pumping energy.

Flexible operating envelope

YHAU-CL/CH-B Single-Effect Absorption Chiller's two-step design provides a wide operating envelope utilizing waste heat as low as 70°C where typically competitive offerings cannot operate. YORK technology provides the flexibility to handle combined heat and power (CHP) systems, comfort or industrial-process cooling applications with outstanding efficiency and reliability.

Water characteristic	Temperature range
Entering cooling-water temperature	as high as 37°C
Leaving chilled-water temperature	as low as 4°C
Entering hot-water temperature	as low as 70°C as high as 160°C
Leaving hot-water temperature	as low as 60°C

	Typical conditions 1	Typical conditions 2
Chilled water in / out	12°C / 6°C	12°C / 7°C
Cooling water in / out	27°C / 32°C	29°C / 34°C
Hot water in / out	90°C / 72°C	90°C / 70°C

Minimizing total cost of ownership

World-class YORK engineering, support and service reduce the cost of ownership by simplifying startup and chiller operation over the life of the system. Here's how:

Better optimized for low condenser or cooling water flow thanks to the two-step design that minimizes cooling water flow rates. Conventional flow designs require higher flow rates.

Fully automatic purging system provides trouble-free peration by purging and removing non-condensable gases without operator intervention.

Superior hermetic integrity is ensured by high quality processes and rigorous helium leak detection technique. Tubes made stainless steel. All of the tubes inside are also plain type without a spiral and fin for easy maintenance. Water boxes are coated with epoxy paint for added **corrosion resistance**.

Control center with graphical animated LCD display lets the user see several operating parameters at once. Present and past operational status, data recording and chiller safeties are accessible at a touch.

Isolation valves on the suction and discharge of the solution and refrigerant pumps allow quick and easy servicing of pumps, which typically have a 60,000-hour life.

The control panel automatically controls the input hot water flow rate to maintain the programmed leaving chilled water set point for cooling loads ranging from approximately 20% to 100% of design.

Factory functional testing on single-piece shipments, ensures control-panel and safety-device operation to reduce on-site startup time in the field.

OpenBlue provides connected experiences to increase productivity, optimize processes, and ultimately provide higher tenant satisfaction. It features a suite of tailored, AI-powered service solutions such as remote diagnostics, predictive maintenance, and advanced risk assessments.

Single-effect hot water cycle with innovative YORK two-step evaporator and absorber design

Ideally suited for combined heat and power (CHP), waste heat recovery, commercial cooling and peak shaving and industrial-process cooling applications, strongly aligned with Johnson Controls vision of a safe, comfortable and sustainable world.

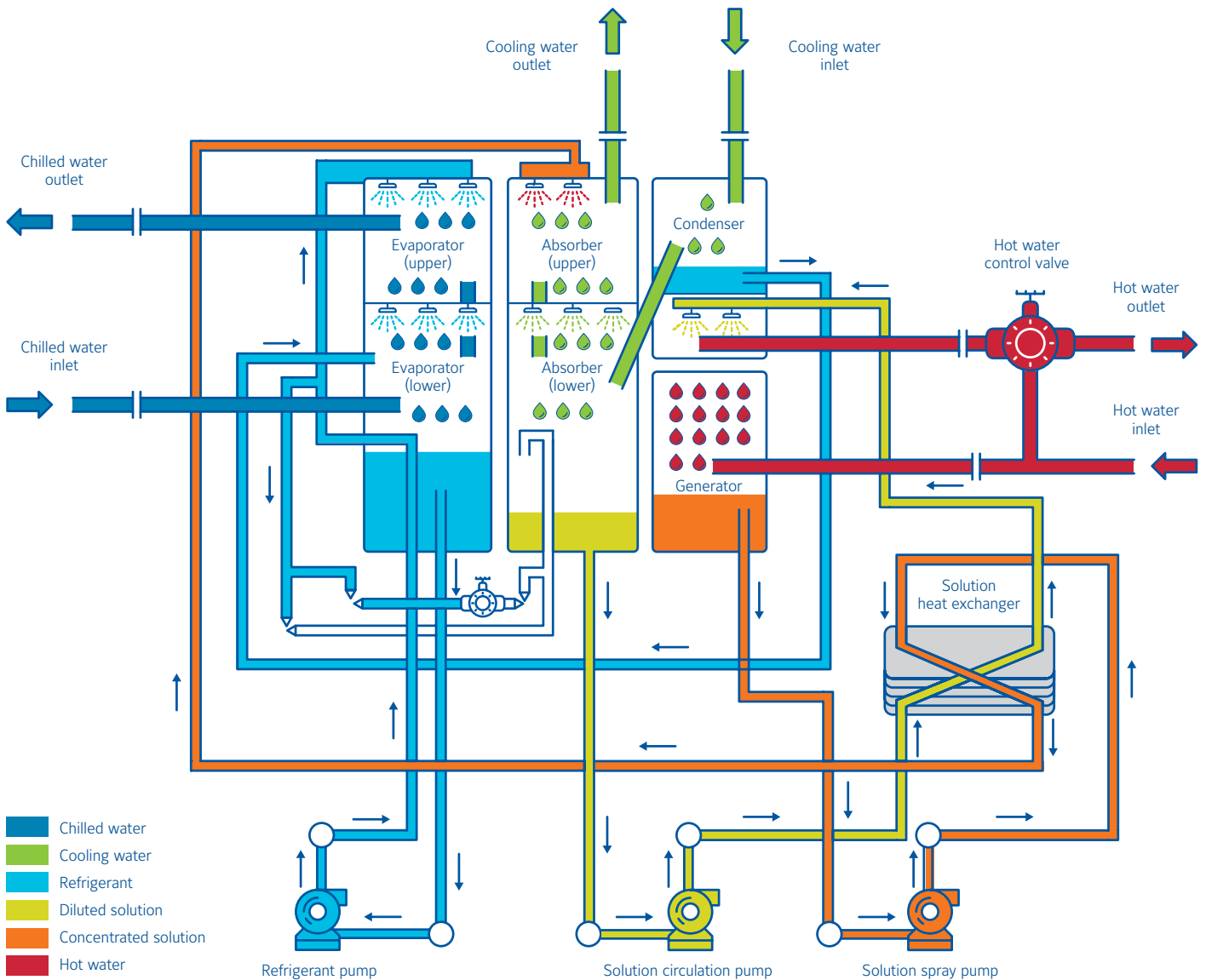

1. Two-step evaporator and absorber design has two pressure levels that uniquely divide the absorption process into two steps. The chilled water flows through the tubes in series through the two evaporators while the concentrated lithium-bromide solution is distributed in the absorber shell side in the opposite direction. This enhances absorption of the refrigerant into the concentrated solution, reducing solution concentrations and overall pressure. This makes the unit more efficient and reliable than conventional designs.

2. Gravity-fed distribution system for the evaporator/absorber employs stainless steel material that prevents corrosion and ensures performance and long life.

3. High-efficiency plate heat exchanger provides increased efficiency over conventional shell and tube.

4. Falling-film generator design provides superior heat transfer compared to a conventional flooded generator. This design also reduces the required amount of lithium-bromide solution to be circulated, decreasing startup time from a cold start. Stainless steel tubes are adopted to prevent stress corrosion cracking, and intermediate tube supports reinforce and extend unit life.

WFC SC

Single Effect Hot Water Absorption Chiller

Cooling capacities from 17.6 kW to 175.8 kW



Features WFC SC

WFC SC chillers from **Yazaki** are single stage hot water driven chillers. Compared to electrically driven chillers the **WFC SC** series can dramatically lower system operating costs when using waste heat. Applications particularly well suited to the **Yazaki WFC SC** absorption chiller include waste heat recovery from cogeneration or biomass, waste heat from district power station or industry as well as solar thermal. This makes absorption cooling an environmentally friendly and cost-saving alternative to conventional air-conditioning systems. A low electrical energy consumption results in low CO₂ emissions and provide a relief for electricity grids by replacing conventional cooling demand peaks. All chillers are pre-filled and ready for "plug & chill".

Driving heat source hot water

WFC SC units can operate with entering hot water temperature from 70 to 95°C.

Refrigerant cycle

The **Yazaki WFC SC** high efficiency single-stage absorption refrigeration cycle uses water as the refrigerant and lithium bromide (non-flammable, non-toxic, ecologically benign and ozone-friendly) as the absorbent. It is the strong affinity and ease of separation that these two substances have for each other that makes the cycle work. The entire process occurs in hermetic vessels in a near complete vacuum.

Single Effect Hot Water Absorption Chiller

WFC SC



Nominal capacity WFC SC

Model				WFC SC 05	WFC SC 10	WFC SC 20	WFC SC 30	WFC SC 50
Cooling Capacity		kW		17.6	35	70	105	175.8
Sound pressure at 1 m		dB(A)		46	46	49	52	52
Cold water	Temperature	Inlet	°C	12.5	12.5	12.5	12.5	12.5
		Outlet	°C	7	7	7	7	7
Cooling water	Cooling performance		kW	42.7	85.5	171	256	427
	Temperature	Inlet	°C	31	31	31	31	31
		Outlet	°C	35	35	35	35	35
Hot water	Power consumption		kW	25.1	50.2	100.4	150.6	251
	Temperature	Inlet	°C	88	88	88	88	88
		Outlet	°C	83	83	83	83	83

Technical data WFC SC

Model			WFC SC 05	WFC SC 10	WFC SC 20	WFC SC 30	WFC SC 50
Dimensions	Length	mm	594	760	1060	1380	1785
	Width	mm	744	970	1300	1545	1960
	Height (with mounting plate)	mm	1756	1920	2030	2065	2085
Operating weight		kg	420	604	1156	1801	2650

OpenBlue Central Utility Plant (CUP)



Whether you have a simple chilled water plant or a complex heating, cooling and power generation plant, **OpenBlue CUP** can reduce costs, increase reliability and enhance sustainability.

What if you could predict the future?

Even better, what if your central plant automatically made adjustments to prepare for that future? **OpenBlue Central Utility Plant** uses predictive algorithms and real-time data to optimize plant design as well as everyday operating decisions. Whether you have a simple chilled water plant or a complex heating, cooling and power generation plant, OpenBlue CUP delivers powerful digital tools to cut energy use and greenhouse gas emissions, reduce costs and increase reliability.



Save Money



Save Energy



Save Water



Earn Rebates



Validate Savings



It's time to change the rules and truly optimize your costs.

Every hour of every day, facility operators can choose from hundreds of possible equipment combinations and set points to maximize energy efficiency. Ever-changing loads, weather and utility prices further complicate decision-making. OpenBlue CUP brings you a better way.

Optimize holistically—every 15 minutes.

OpenBlue CUP software optimizes dispatch decisions every 15 minutes to minimize utility costs and maximize potential utility program revenues, based on myriad inputs:

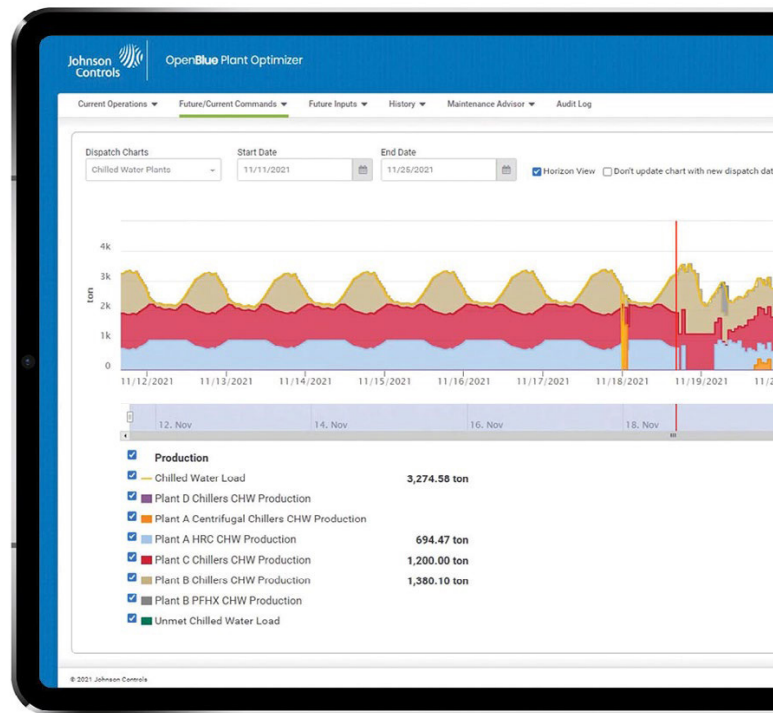

Equipment Performance Models

Every major piece of equipment, including chillers, boilers, pumps and cooling towers, has a model that predicts the equipment's energy performance and cost under all operating conditions. These models are adaptive; as equipment conditions change, the system tunes the models to optimize performance.



Weather Forecasts

Seven-day forecasts for temperature, humidity and cloudiness are pulled from a web-based source for your specific location. The algorithms recognize that forecast accuracy improves as events draw closer in time. These inputs are used to predict loads, equipment performance and ambient conditions.



Load Predictions

The software predicts hourly cooling, heating and power loads for the next seven days. These predictions are based on historical loads, weather, day of week, time of day, building schedules, and special events. The tool then adjusts operations and makes decisions based on those predictions to ensure the reliable delivery of utility services.



Utility Pricing

OpenBlue CUP can model everything from simple flat rates to time-of-use and demand-based rates to complex real-time pricing and incentive programs. Unlike traditional optimization methods, this cost-based approach empowers you to manage demand charges and other more complex tariffs—a major portion of your utility budget.



Calendars and Maintenance Schedules

The software incorporates building schedules to predict loads, accounting for weekends, holidays and special events. Equipment maintenance schedules are also used to optimize systems before, during and after equipment is taken out of service. If equipment goes out of service unexpectedly, the system re-optimizes based on the remaining available equipment.



Connected Chillers

A strategic, behind-the-scenes approach to optimized maintenance and performance

Proactive, not reactive, for peak performance

We're there before you need us

Johnson Controls knows it is essential to quickly identify and resolve operational issues before they become a problem. Our teams are swift to react – but we prefer not to let it get that far.

We take a strategic, proactive stance, actively investigating HVAC equipment data through our suite of cloud-hosted connected assets. By monitoring your system through remote troubleshooting and diagnostics, we can identify issues, take corrective actions and prescribe targeted, timely maintenance to prevent breakdowns from happening in the first place.

You can feel confident knowing your chiller will always be in top form, operating reliably and efficiently.

Prevention is better than cure

A chiller is one of the most critical pieces of equipment in your facility. It is responsible for the comfort of your environments and the productivity of your people.

With OpenBlue Connected Chillers, you can take maximum control of how your environment functions with strategies around planned, predictive and proactive maintenance that find and fix small issues before they become big problems that hit your output and your pocket.

Because chillers can consume as much as half of the total energy used in a building, high efficiency levels are paramount to optimizing how your spaces operate and impact on your bottom line.

Our world-class chillers provide an exceptional level of efficiency, where their operation is an art in itself. And when they are OpenBlue Connected Chillers, pairing data-driven insights with the knowledge of our OpenBlue Chiller Experts, their efficiency is exponential, increasing overall equipment performance.

At Johnson Controls, sustainability is a part of everything we do. It can be for you, our customers, too.

Finally, achieving your sustainability goals doesn't affect your bottom line. The path to net zero leads through reduced energy use, cut costs and boosted efficiency. Our digitally enabled services save you money and save you time while helping save our planet.

We put our global expertise and more than a century of innovation excellence behind every Johnson Controls solution.

Proactive first and reactive second, it's always business as usual with us as we don't interrupt your day-to-day operations.



OpenBlue Connected Chillers – a key part of OpenBlue Net Zero Buildings
Save the planet while saving money

How Connected Chillers work



Selection of deliverables



Regular reports
With less time than ever to analyze the different aspects required to run a building properly, our team of experts assesses and cross-checks the status of your chillers to give you regular, relevant reports.



Health check
We use algorithms to produce accurate, accessible reports for you to check the condition of your chiller's health.

This is a potential deliverable provided by our OpenBlue Chiller Experts.



Health check with enhanced comments
Our experts review and analyze algorithm data to identify any possible dysfunction of the chiller and explain its associated risks to provide clear recommendations.



Virtual inspection
We provide customized reports from our top experts, providing the intelligence to not only maintain your chiller but also enhance its efficiency with suggested adjustments that could help you optimize operations.

Heat Pump Solutions

According to the Environmental Protection Agency (EPA), it is estimated that 5% of the world’s daily energy consumption is expended on fuel for heating water. Additionally, in Western European countries, 25 % of primary energy used is for cooling and heating applications. As pressure continues on natural resources and energy bills continue to rise, we must seek new, environmentally friendly solutions.

One smart option is to improve the energy utilization of your facility’s heating and cooling system by recycling heat energy that would otherwise be rejected. This can be accomplished with a Johnson Controls heat pump.

At Johnson Controls we set standards without compromising our core principles: and when passion and innovation come together, great things happen!

What is a Heat Pump?

Heat pumps are designed to produce hot water at a specified temperature. Heat is extracted from a low-temperature source such as air, ground water, or waste process heat, and its temperature is raised to a level where it can be used in alternative processes.

There are 4 primary system designs for heat pumps:

- 1) Air-source** – An example of this is the heat pump you may have in your home.
- 2) Ground-source** – This system uses the ground as the heat source, often used in residential or light commercial applications.
- 3) Water-source** – This system uses a building’s water supply to transfer heat. This is the most commonly used system.
- 4) Cascade-source** – The system uses heat from existing refrigerant systems or any available waste heat source.

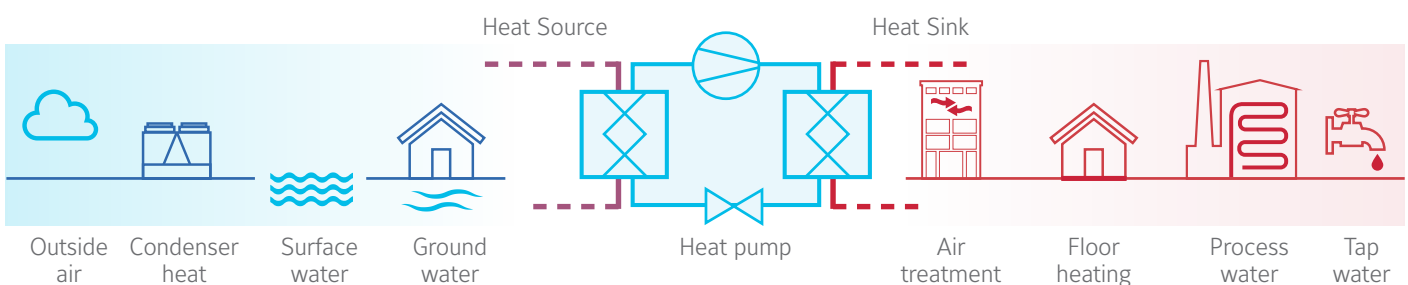

Traditionally, chillers are used to provide a building’s required cooling load (rejecting heat to atmosphere via cooling towers) and boilers supply hot water to meet the building’s heating needs. Using a Heat Pump gives increased system efficiency and lowers operating expense as they can supplement or even replace existing heating systems, and can also operate in reverse cycle to provide cooling during the summer. There are also processes in which cooling and heating functions perform simultaneously. Again, heat pumps are an ideal solution to this challenge.

Benefits of using heat pumps

Traditional systems used to heat water for hydronic heating and domestic hot water are not energy efficient. Heat pumps offer a number of advantages when compared to fossil-fuel water heaters:

- Higher COPs offer **energy cost-savings above 50%**.
- Thanks to their efficiency and short amortization period, they represent an environmentally compatible and economically attractive alternative to conventional heating systems. **Potential payback of the heat pump can be less than 2 years.**
- **Low operating-cost supplement** to water heaters where total heating requirement exceeds heat pump capacity.
- **Heat pumps can also be used as water chillers**, which means lower first-costs, as one item of equipment performs cooling and heating.
- **Life cycle of over 20 years.**

Johnson Controls heat pumps offer additional benefits by using environmentally friendly HFC and natural refrigerants, with **zero ozone depletion potential, and low global warming potential.**









Reduced operating costs

The best way to compare the efficiency of a heat pump and a water heater is to do a COP analysis. COP equals the energy output (useful heat generated) divided by the energy input (energy supplied to the equipment).

Accordingly, the higher the COP, the more efficient the system – and the lower your running costs!

As an example we can take a 1800 kW water-cooled heat pump as the one showed in chart and compare it to a natural gas boiler. When you compare the efficiency of a boiler to a heat pump, the heat pump comes out way ahead.

In the example given it's possible to save up to 53% in the energy bill vs the traditional natural gas boiler!

Hot Water Requirement	Energy Source	Efficiency	Energy Consumption	Cost of Source*	Cost of Hot Water Requirement	HP Saving vs Gas Boiler
1 kWh 	Natural Gas Boiler 	Average efficiency COP=0.9	 1 kWh / 0.9 1.11 kWh	European Avg. Gas Cost 0.041 €/kWh	1.11 kWh x 0.041€/ kWh 4.5 c€	-
1 kWh 	Air cooled Heat Pump 	Average efficiency COP=3.2	 1 kWh / 3.2 0.31 kWh	European Avg. Electricity Cost 0.12 €/kWh	0.31 kWh x 0.12€/ kWh 3.7 c€	18%
1 kWh 	Water cooled Heat Pump 	Average efficiency COP=5.5	 1 kWh / 5.5 0.18 kWh	European Avg. Electricity Cost 0.12 €/kWh	0.18 kWh x 0.12€/ kWh 2.1 c€	53%

* Cost of Source: Eurostat Statistics web site.













CO₂ footprint reductions

Another benefit that offers heat pump technology is the reduction in CO₂ emissions from fossil fuel use. Heat pumps are a highly efficient electric alternative.

If we refer to the same example with a 1800 kW water-cooled heat pump and compare it to a natural gas boiler, the reduction in CO₂ emissions is impressive.

In fact 1322 tons of CO₂ annually can be saved, which is the equivalent of removing about 278 cars* from the road!

* www.epa.gov/cleanrgy/energy-resources/calculator.html

Hot Water Requirement	Energy Source	Efficiency	Energy Consumption	CO ₂ Source Emissions*	Carbon Footprint	HP CO ₂ footprint reduction vs Gas Boiler
1 kWh 	Natural Gas Boiler 	Average efficiency COP=0.9	 1 kWh / 0.9 1.11 kWh	CO ₂ Emissions 204 g CO ₂ / kWh	 1.11 kWh x 204g CO ₂ /kWh 226 g CO ₂	-
1 kWh 	Air cooled Heat Pump 	Average efficiency COP=3.2	 1 kWh / 3.2 0.31 kWh	CO ₂ Emissions 541 g CO ₂ / kWh	 0.31 kWh x 541g CO ₂ /kWh 167 g CO ₂	26%
1 kWh 	Water cooled Heat Pump 	Average efficiency COP=5.5	 1 kWh / 5.5 0.18 kWh	CO ₂ Emissions 541 g CO ₂ / kWh	 0.18 kWh x 541g CO ₂ /kWh 97 g CO ₂	57%

* CO₂ Source Emissions: UK Department of Energy, Food and Rural Affairs and carbonindependent web site

Reduced water and chemical consumption

When a heat pump is operating we are keeping heat within the building and not rejecting heat to the atmosphere. In other words, we're saving condenser water from evaporating.

So when we look at our same 1800 kW water-cooled heat pump example again, how much water are we saving by not expelling heat to the atmosphere from the cooling tower?

Over 26 million litres annually!

LEED points

Heat pumps will help you and your customers get LEED points. LEED is one of the most recognizable bodies that certifies building designs to demonstrate leadership in environmental impact.

The use of a heat pump also helps accreditation for BREEAM and other similar schemes.



Heat Pump solutions

We do have a wide range of industrial heat pumps for several capacities and at different temperature levels.

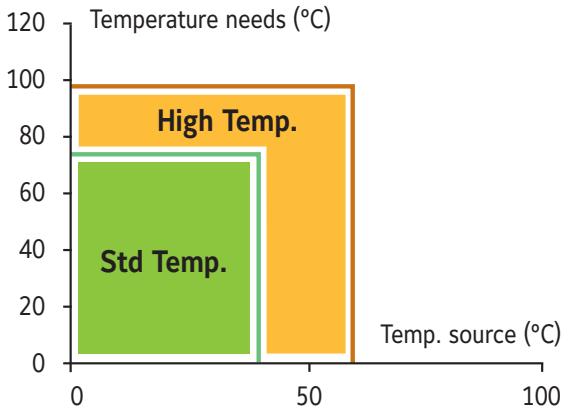

Compressor type	Refrigerant
Scroll	R410A, R454B, R454C, R290
Screw	R134a, R513A, R717
Centrifugal	R134a, R513A, R1234ze, R1233zd(E)
Reciprocating	R717
Absorption	R718

Special products and customized heat pumps

Below data are for reference only and may vary. Please contact your JCI representative for more details and customization.



YK
Water to water heat pump
VSD Centrifugal compressor / R1234ze
Hot water up to **68°C**
Hot water up to **93°C (High Pressure casing only)**
Heating capacity: 1000 to 9000 kW



CYK HP
Water to water heat pump
Dual-Centrifugal compressors, Series-Arrangement / R1234ze
Hot water up to **93°C**
Heating capacity: 1500 to 10000 kW



Titan OM HP
Water to water heat pump
Multi-stage Centrifugal, electric, steam or gas driven / R1234ze
Hot water up to **95°C**
Heating capacity: 5000 to 20000 kW

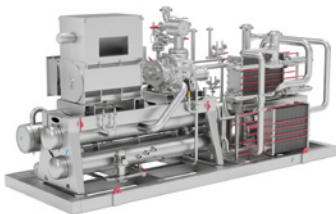

HicaHP
Water to water heat pump
Screw compressor / R717
Hot water up to **95°C**
Heating capacity: up to 7000 kW

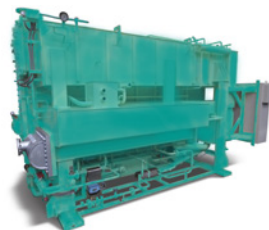

YHAP
Single stage absorption
Steam, Gas or Hot Water driven / R718
Hot water up to **95°C**
Heating capacity: 900 to 40000 kW

YORK Heat Pump products are Outside the scope of AHRI Water-Cooled Water-Chilling and Heat Pump Water-Heating Packages Certification Program or not optionally certified. Refer to the following AHRI site at <https://www.ahrinet.org/certification/ahri-certification-programs> for air-cooled and water cooled Program Scope, Inclusions, and Exclusions. For verification of certification, go to the AHRI Directory at www.ahridirectory.org

Heat pumps with standard temperature



YMAE
Air to water HP
Scroll / R454B
Hot water up to **60°C**
Heating capacity:
38 to 124 kW



YMPA
Air to water HP
Scroll / R454B and R410A
Hot water up to **55°C**
Heating capacity:
45 to 256 kW



YLPB
Air to water HP
Scroll / R410A
Hot water up to **52°C**
Heating capacity:
344 to 653 kW



YCPB
Air to water HP
Scroll / R454B
Hot water up to **60°C**
Heating capacity:
305 to 507 kW



YAS/Rc-WP
Air to water HP
Scroll / R290
Hot water up to **55°C**
Heating capacity:
103 to 334 kW



YTL
Air to water HP
Scroll / R454B
Screw / R513A
Hot water up to **55°C**
Heating capacity:
202 to 1151 kW



YCH
Air to water HP
Scroll / R454B
Screw / R513A
Hot water up to **55°C**
Heating capacity:
50 to 1455 kW



YHA
Air to water HP
4 pipe system
Scroll / R410A
Hot water up to **60°C**
Heating capacity:
22 to 464 kW



YLZ
Air to water HP E.V.I
4 pipe system
Scroll E.V.I / R410A
Hot water up to **65°C**
Heating capacity:
24 to 210 kW



YMWA
Water to water HP
Scroll / R410A
Hot water up to **55°C**
Heating capacity:
24 to 215 kW



YWH
Water to water HP
Scroll / R134a
Hot water up to **78°C**
Heating capacity:
38 to 301 kW



YCSE HP
Water to water HP
Screw / R134a
(R513A on request)
Hot water up to **50°C**
Heating capacity:
170 to 300 kW



YWW
Water to water HP
Scroll / R454B
Hot water up to **50°C**
Screw / R1234ze
Hot water up to **65°C**
Heating capacity:
100 to 225 kW

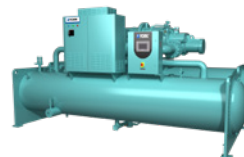

YVWH
Water to water HP
VSD Screw / R1234ze
Hot water up to **50°C**
Heating capacity:
315 to 1250 kW



YVWH High Head HP
Water to water HP
VSD Screw / R1234ze
Hot water up to **80°C**
Heating capacity:
800 to 1600 kW



YZ
Water to water HP
VSD Centrifugal
Magnetic bearings
R1233zd(E)
Hot water up to **45°C**
Heating capacity:
1000 to 6800 kW



YMC²
Water to water HP
VSD Centrifugal
Magnetic bearings
R513A
Hot water up to **65°C**
Heating capacity:
1600 to 3000 kW



YK
Water to water HP
VSD Centrifugal
R513A
Hot water up to **50°C**
Heating capacity:
1000 to 9000 kW



HeatPAC recip
Variable-Speed Drive
Reciprocating / R717
Hot water up to **90°C**
Heating capacity:
up to 2700 kW



DualPAC recip 2-stages
Variable-Speed Drive
Reciprocating / R717
Hot water up to **90°C**
Heating capacity:
400 to 2900 kW

HVAC Fundamentals

Chilled water systems

Air conditioning system designs normally use supply chilled water temperatures of 5°C to 8°C. Some systems, such as chilled ceilings or beams, may use higher temperatures up to 14°C or 15°C.

If leaving temperatures less than 4.5°C are required brine solutions are used to prevent freezing. This is specially the case with Ice Storage Systems that can have temperatures as low as minus 7°C.

The cooling capacity of a Chiller increases with rising leaving chilled temperatures. A temperature difference, between flow and return, of 5°C to 8°C is normal.

The water flow volume is dependent on the cooling capacity and chilled water temperature difference in the following formula:

$$\text{Water Flow Volume (Litres per Second)} = \frac{\text{COOLING CAPACITY (kW)}}{\text{Density (kg/m}^3\text{) x Specific Heat (kJ/kg}^\circ\text{C) x Temperature Difference }^\circ\text{Cx1000}}$$

The resulting water flow must be checked against the flow limitations of the Chiller. This can be found in the "Limitations Table" for each type of Chiller or heat pump (data is not in this catalogue).

A small temperature difference achieves a low **mean water temperature** which will generally allow the selection of smaller cooling coils in Air Handling Units and Fan Coil Units etc.

Conversely water flow volume will be high resulting in a larger circulating pump and increased pressure drop through the Chiller and coiling coils and a consequent increase in operating costs.

The pressure drop varies as the square of the flow and is defined in the following formula:

$$H2/H1 = (W2/W1)^2$$

H1 = Pressure Drop kPa at final condition

H2 = Pressure Drop kPa at original condition

W2 = Flow rate L/s at final condition

W1 = Flow rate L/s at original condition

Selecting the optimum temperature difference is therefore a compromise between operating costs and equipment size and the capital cost of such equipment. Primary chilled water temperature differences are normally between 5°C and 6°C. Generally a minimum system flow volume will provide the least expensive system in both capital and operating costs.

An Air Conditioning system in a building comprises a variety of components, such as Chillers, Air Handling Units, Diffusers, Ductwork, Pipework, Controls, Electrical Wiring, etc.

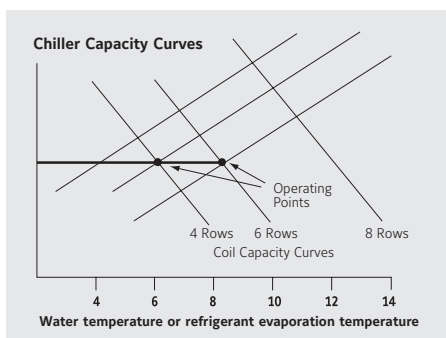

An optimisation of the system price, function and efficiency must consider all components and their interaction. It starts with the load calculation. A floating temperature setpoint in the comfort range area will save energy and reduce operating costs. Capital costs can be reduced by balancing the selection of Chillers, Air Handling Units, Ductwork sizes, etc. It is important to determine the optimum operating point that balances the selection of the Chiller leaving water temperature and the Air Handling Unit cooling coil. A temperature rise of 1°C in water temperature yields approximately 3% more capacity for the Chiller and reduces the absorption input power typically by 1.5%. However the coil capacity reduces with temperature rise and requires larger heat exchange surfaces (more rows and/or a lower fin spacing).

If the leaving water temperature of the Chiller is raised it is possible that one Chiller size smaller can be selected.

The capital cost for the larger coil is comparatively small and the cost savings of a smaller Chiller can be considerable.

Increasing the leaving chilled water temperature will also increase the air temperature leaving the Air Handling Unit coil and this may in turn decrease the supply and return air temperature difference.

The Air Volume is determined by the following formula:

$$\text{Air Volume m}^3/\text{s} = \frac{\text{HEAT GAIN (kW)}}{\text{Density (kg/m}^3\text{) x Specific Heat (kJ/kg}^\circ\text{C) x Temperature Difference }^\circ\text{C}}$$

A smaller air temperature difference will increase the air volume and therefore the duct sizes and resultant cost of the ductwork. It is therefore important to consider the total impact on all the components of the air conditioning system. Lower supply air temperatures will reduce the size of both ductwork and Air Handling Units and specially designed air diffusers can be used to ensure that the lower supply air temperatures have no adverse effect on the building occupants.

Piping system design

On larger air conditioning systems it is generally recommended that "Reverse Return" piping arrangements are used to ensure balanced flow rates.

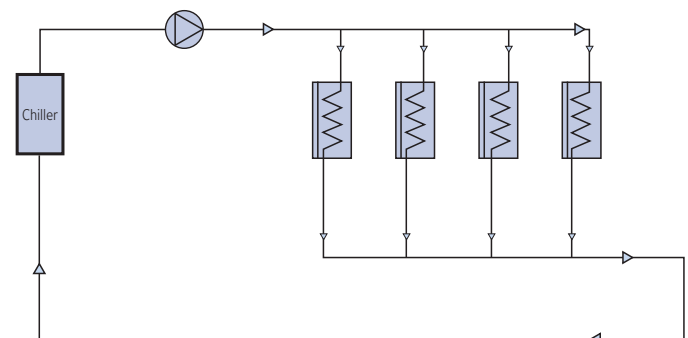

Minimum system water volume

To allow the Chiller or Heat Pump to operate smoothly at low load capacities sufficient thermal storage is required in the primary water circuit to give at least 5 minutes operation when the machine is not running. This will ensure that the equipment will not continuously stop and start at low load conditions and consequently cause undue wear on the compressor.

The following formula will satisfy the total required thermal storage volume:

$$V = \frac{(N \times 60 \times Z)}{4.18 \times dt}$$

V = Total system water content (Litres)(4.18 x dt)
 N = Capacity of the Chillers first capacity step (kW)(4.18 x dt)
 Z = Minimum allowable running time (minimum 5 min.)
 dt = Temp. difference at the minimum partload condition

$$V = 35.88 \times S \times Q$$

S = Minimum capacity step (at lowest operating ambient)
 Q = Full capacity at nominal conditions

Chiller cooler connection

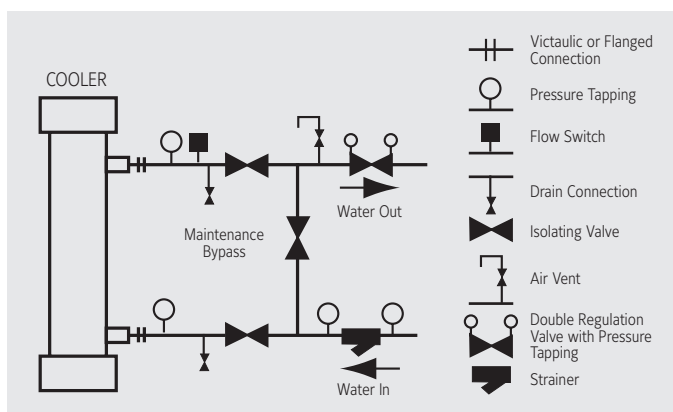

In order to ensure a trouble-free operation of the cooling water pump during startup of the system, the entire cooling water piping should be as far as possible below the operating level of an open circuit cooling tower. This prevents emptying of the cooling water lines in the cooling tower trough.

If multiple cooling towers are used in a common cooling water circuit, compensation pipes must be installed between the cooling tower tanks in order to keep the cooling water in all cooling towers at the same level. If more than one water entry into the cooling tower is required, install throttle valves to balance the flow between circuits. Check that the pressure of the spray nozzles and the pressure of the make-up water are not exceeded.

Warm water system

The leaving water temperature from a Heat Recovery Chiller or a Heat Pump is normally between 45°C and 60°C depending on the refrigerant that the machine is charged with. For Heat Pumps more heating capacity and higher operating efficiency is available with lower leaving water temperatures. Water temperatures of 45°C to 50°C are quite adequate for the selection of heating coils in Air Handling Units and Fan Coils.

Refrigerant to water condensers are limited in the volume of water that can be passed through them and it is necessary that this limitation is considered during the system design process. This may result in a larger water temperature differences than those used in a normal Boiler fed low temperature hot water system. The water temperature can be increased from a Boiler but measures must be taken to ensure that the return water to the Chiller or Heat pump cannot ever exceed 60°C.

Chiller condenser connection

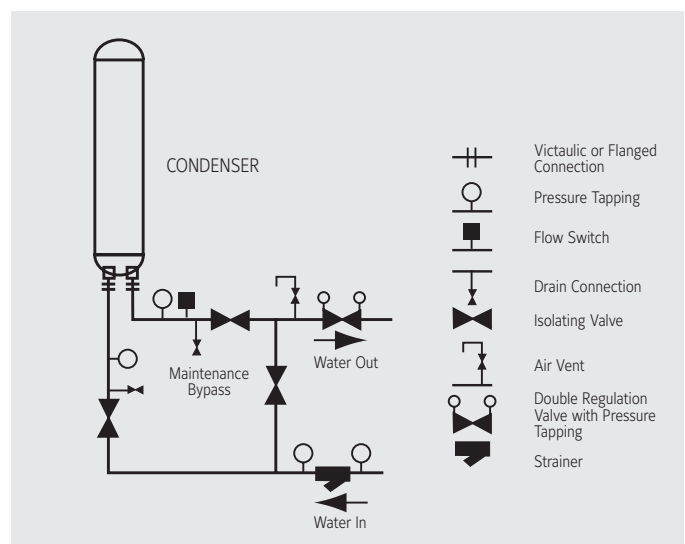

Chiller condenser water systems

To ensure satisfactory pump operation at start-up and to prevent overflowing of the Cooling Tower sump all condenser piping, and as much tower piping as possible, should be installed below the operating level of the tower. If multiple towers are used on a common system equalising lines should be installed between the sumps of the separate Cooling Towers to ensure balanced water level in all the towers. If more than one inlet connection is required to a tower balancing valves should be installed to give the required flow to each circuit. Check that the maximum spray water and make-up water pressures are not exceeded.

Circulating pump selection

Pumps should have a flat characteristic and should operate near to the left of the maximum point of efficiency on the curve to allow for any deviation in the position of the actual system curve from that estimated in the design process. This will ensure satisfactory pump operation with no overloading of water volume or reduction in available head.

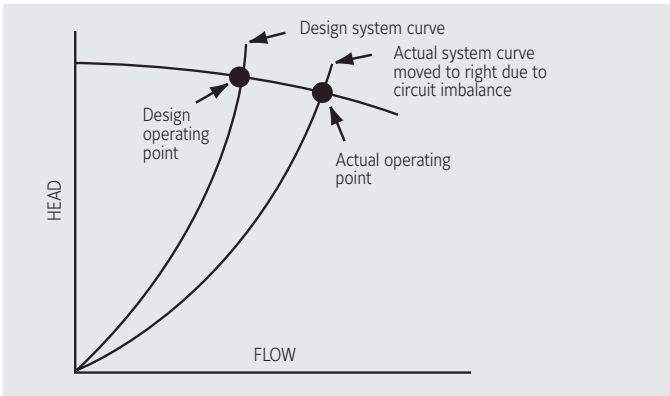

Parallel pumps

When two pumps, of equal flow, are used in parallel they operate at the same head and share the total system flow. When only one of the two pumps is in operation the flow volume can be as much as 80% of total flow resulting in a very good performance for stand-by in case of pump failure.

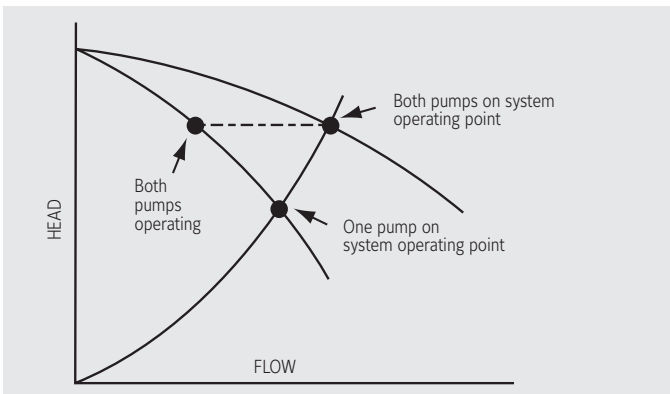

Series pumps

When two pumps, of equal flow, are used in series they operate at the same flow and share the total system head. When only one of the two pumps is in operation the flow volume can be as much as 80% of total flow resulting in a very good performance for stand-by in case of pump failure.

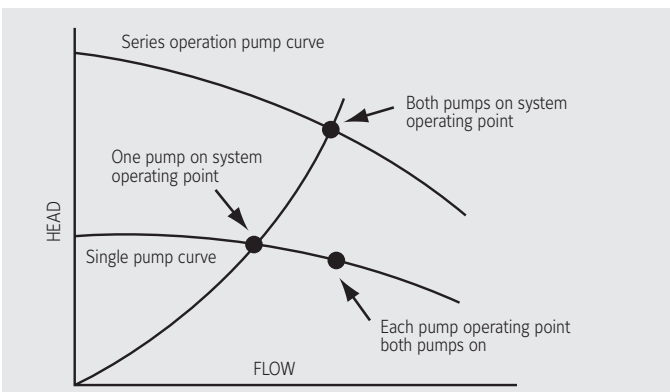

System pressurisation

A diaphragm expansion tank, pre-charged to the system fill pressure and sized to accept the expansion of the water, is normally used in larger water circulating systems. The air charge and the water are permanently separated by a diaphragm that eliminates corrosion and noise caused by air in the system.

Water treatment

Water system problems can be recognised from the following symptoms:

1. A reduction in heat transfer, which is a sign of insulating deposits on heat transfer surfaces reducing the cooling or heating efficiency of the equipment. This can be caused by scale or biological growths.
2. A reduction in water flow which is generally caused by a restriction in pipework, condenser or evaporator tubes or other components due to a build-up of scale. Bacterial and algae accumulate in Cooling Towers and can radically reduce water flow and are a major cause of corrosion. As the water evaporates in a Cooling Tower the dissolved solids originally present in the water remain in the system and suspended solids scrubbed from the air can also contribute to the blockage and corrosion of condenser water pipework and the Chillers condenser tubes.
3. Corrosion of materials or undue wear to pumps, shafts, seals etc. Unless a Cooling Tower is regularly cleaned and protected with adequate water treatment biological contaminants, including Legionella, may be introduced into the re-circulating water.

A water treatment program must be employed to control all possible contaminants. It must be compatible with all the materials of construction and the pH of the circulating water must be maintained between 7 and 9. Biological contamination can be controlled by the use of biocides.

The proper control of water treatment is dependent on the proportional addition of the relevant chemicals to maintain the correct concentration at all times. The relevant chemical treatment of water systems is a complicated matter and it is therefore important that a specialist water treatment company is involved early in the design stage of the project.

Mechanical filtration

A Filter, with a 40 mesh screen, must be installed as close as possible to the water inlet of both the cooler of air cooled and water cooled Chillers and Heat Pumps and the condenser of water cooled equipment. A means of local isolation should be provided. The Filters will also protect the circulating pumps in the system.

Sound

Noise is a major comfort criterion and has considerable effect on the well being of human beings. Noise is generated by friction due to moving parts, compression, explosion etc.,. Mechanical forces create vibration of components which radiate noise in the frequencies of the mechanical source. Deep frequencies cause rumbling which is transported via the structural elements of a building and can be experienced by the sense of touch and body vibrations. Higher frequencies are transported by air. The vibration compresses and expands the air around the noise source and the varying pressure waves are transmitted in all directions.

Sound pressure Lp

Sound pressure is the noise emitted from an object in a series of high frequency pressure waves which move through the air in a similar pattern to the water ripples caused when a stone is thrown into a pond. It radiates outwards from the sound source and is reflected from objects and surfaces in its path.

The magnitude of a sound pressure wave is measured in pascals (N/m²) but in order to correspond with the human perception of sound. A logarithmic scale is used with decibel (dB) units. Most internationally accepted scales use zero decibels as a sound pressure wave of 0.00002 pascals in height which is approximately the threshold of human hearing. As this is a logarithmic scale each time the size of the pressure wave increases by a factor of ten the decibel scale increases by the number ten, ie., 70 dB represents a pressure wave 1000 times greater than 40dB. This corresponds to the human perception of sound which would also rate the 1000 times increase in sound pressure as a 30 times increase in loudness.

Sound pressure is given the symbol Lp.

$$L_p = n \text{ dB re } 2 \times 10^{-5} \text{ Pa}$$

The human ear can normally detect sound to as low as 2×10^{-5} Pa.

Sound pressure is projected at a specific distance from the source and is effected by the surroundings.

Sound power Lw

Energy is required to generate a sound pressure wave and the size of the wave is directly related to the amount of energy used.

A continuous sound will only be produced if continuous power is available. Sound power can be measured in watts but it is more convenient to use a logarithmic scale and decibel units. As a basis for the sound power scale 1 picowatt is generally taken to be 0 dB. In order to find a measure for noise a ratio is taken between the sound power and a reference sound power of $P_0 = 10^{-12}$ Watts

Sound power is NOT distance dependant.

Sound power is the property of the noise emitting object and sound pressure is used to measure the pressure waves which carry the sound to the ear.

Sound power is given the symbol Lw.

$$L_w = n \text{ dB re } 10^{-12} \text{ W}$$

Example:

The human voice has an average sound power of 10^{-6} W.

$$L_w = 10^{-6} / 10^{-12} = 10^6$$

Translated into logarithmic figures:

$$L_w = 10 \times \log 10^6 = 10 \times 6 = 60 \text{ dB}$$

If two sound sources of equal power (60 dB or 10 W each) were active their added sound level would be as follows:

$$(10^{-6} + 10^{-6}) / 10^{-12} = 2 \times 10^{-6} / 10^{-12} = 2 \times 10^6 = 2 \times 10^6$$

$$L_w = 10 \log (2 \times 10^6) = 63 \text{ dB}$$

Therefore: 60 dB + 60 dB = 63 dB.

Therefore if two sound sources have the same sound power add 3 dB.

For several sound sources of having the same sound level refer to the following graph.

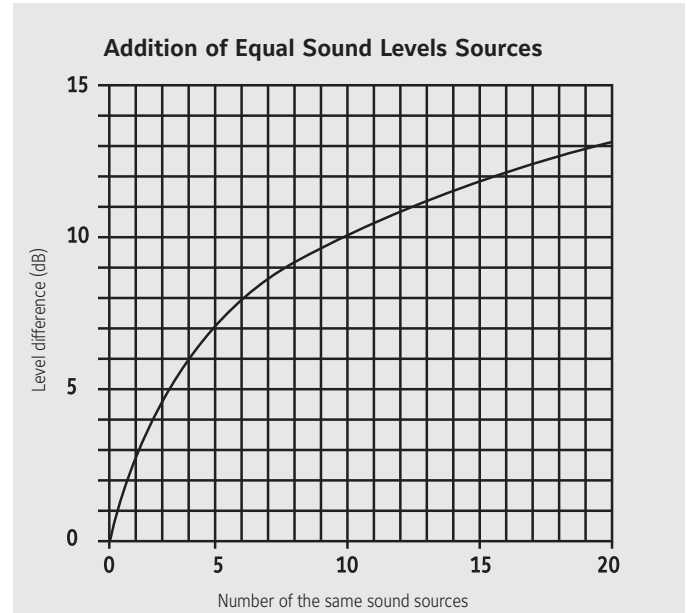

When sound sources of differing sound levels are to be added refer to the following table.

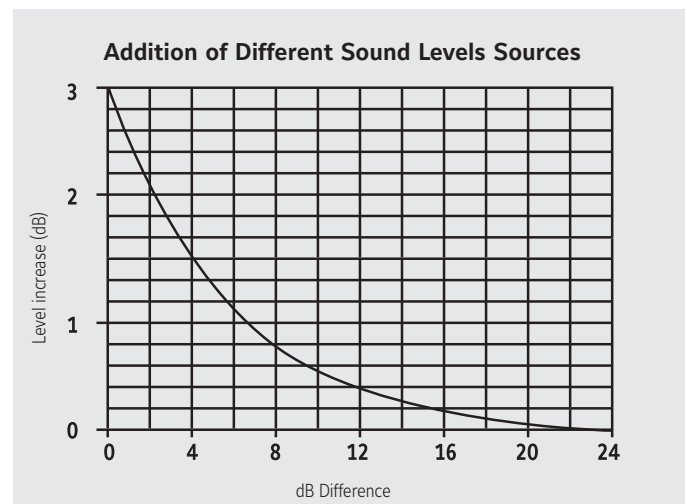

Weighting scales dB(A)

The human ear detects the single frequencies with different intensity and it has therefore been necessary to establish a method that simulates human hearing. In order that a single overall sound output value of an object may be determined a weighted or averaged value, that assimilates human hearing, can be taken of the sound level in each frequency of the frequency band between, the lowest and the highest, which can be heard.

The generally accepted bands are centred on 62.5Hz which is then doubled each time to a peak of 8000Hz (8kHz). These are the octave bands . The most commonly used weighting curve is the "dBA" scale. Weighted dB differences are subtracted from the source frequency band values and the resulting dB(A) value will therefore be lower than the unweighted.

The ratio sound pressure/sound power

The relationship between sound pressure waves and the sound power of the object producing them depends on the nature of the area around the object and the location of the person effected by the sound.

In order to take accurate sound measurements it is preferable to have a "Free Field" environment. This is an area having constant properties, free of boundaries or objects or any other sound source which could effect measurements. The sound waves radiate outwards in concentric hemispheres from the source getting weaker as the distance increases. The average sound level at the surface of one of these hemispheres is directly related to the sound power of the machine which is assumed to be generated at a point at the geometric centre of the machine. If an object is large, relative to the distance from which sound measurements are taken, the sound cannot be considered to be coming from a single point and the sound level will depend on where the subject is standing. The sound level can vary considerably with a small change in position and it is not therefore possible to relate sound pressure to sound power using Near Field measurements.

Site installations are seldom a free field environment . Adjacent buildings, walls etc, affect the sound pressure waves and a wall in close proximity can increase the sound level on the opposite side of the machine by reflecting the sound back in that direction.

Noise criteria (NC) curves

The ear can only perceive the pressure variations of air pressure not the sound power itself. The radiated sound power is transformed into sound pressure, part of which is absorbed by the environment and such objects as carpets, clothes etc, that may be situated within the wave pattern, and the intensity decreases with distance. This effect is called "Room Effect".

The difference between the sound power and the received sound pressure can be read from a diagram. The noise dB curve at the single frequencies is plotted and compared with reference curves. The value of the highest reference line that touches the noise curve is the NC value.

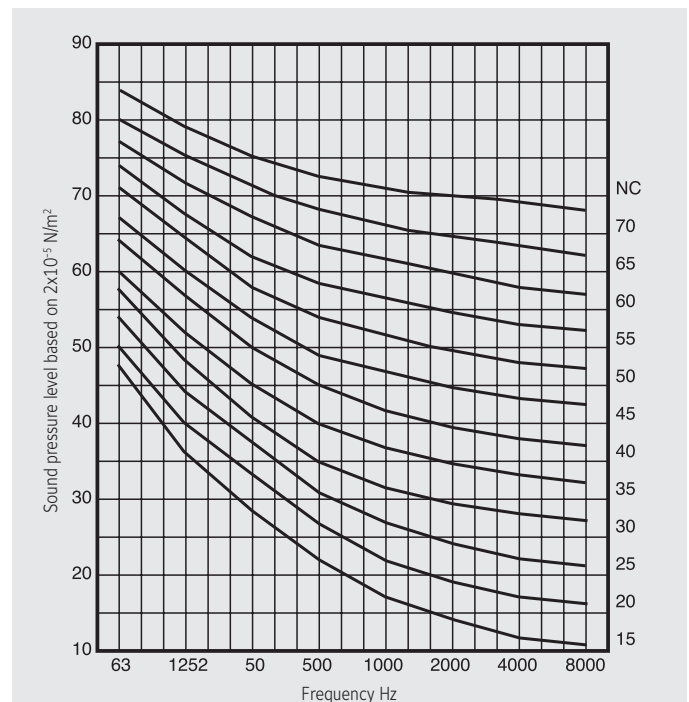

Chiller sound measurement

Chiller sound power

Sound Power is the property of the chiller only and can be used directly to compare the Sound Power of the chillers of one manufacturer against another. Most Sound Power data is quoted with reference to standard ISO 3744 which is entitled 'Sound Power Levels of noise Sources' and is sub-titled 'Engineering methods of determination of sound power levels for sources in free field conditions over a reflective plane'. This standard refers only to Sound Power values.

Sound power values are not distance-dependant

The basic method described by the standard involves averaging a number of sound pressure measurements taken all over an imaginary surface around a chiller in free field conditions.

Providing that background noises are within prescribed limits all of the sound measured at the surface must be coming from the chiller and the sound output (power) can be calculated as follows:

$$L_w = L_p + 10 \times \log_{10}(S)$$

Where:

L_w = Sound power in dB (reference value: 10⁻¹²W)

L_p = Average value of the sound pressure measurements in dB
(Reference value: 2 × 10⁻⁵ Pa)

S = Measuring area in square meters

Chiller sound pressure

Chiller manufacturers use the parallelepiped method (rectangular box) of constant distance D from the surface of the chiller to measure the Sound Pressure. The use of this shape does not change the calculated Sound Power for the chiller.

For example to calculate the sound pressure at 10 metres for a chiller with an 'A' weighted overall **Sound Power of 107dB(A) re 10⁻¹²W** and a rectangular surface area at 10 metres distance of 1778 m² using the parallelepiped surface:

$$\text{Sound pressure at a distance of 10 meters} = 107 - 10 \times \log_{10}(1778 \text{ m}^2) = 107 - 32.5 = \mathbf{74.5 \text{ dB(A)}} \text{(reference value } 2 \times 10^{-5} \text{ Pa)}$$

Some manufacturers quote sound Pressure levels at a distance of one metre. When a chiller can be anything up to 10 metres in length this distance is illogical, as the sound level will change depending upon the position along the unit. That is near to the compressor will be noisier than near to the control panel etc, Even a distance of 5 metres is too close in the case of very large chillers.

Deduction from Sound Power Level to Obtain Sound Pressure Levels at Various Distances from a Chiller

Distance "D" in meters	5	10	25	50
Deduction from sound power	-28	-32	-39	-45

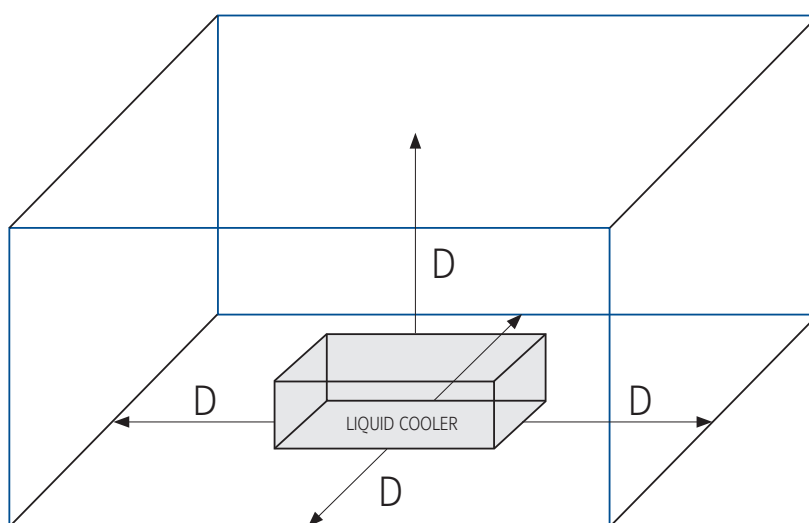

Ecodesign Directive for HVAC Chillers and Heat Pumps

EU Energy and Climate Policy Context

European 2050 Vision towards a low carbon economy is targeting reduction of 80/95% of the Green-house gas emissions by looking at the reduction of the 3 following parameters and comparing to the values of 1990.

	2020	2030	2050
Primary Energy consumption	-20%	-27%	
Green-house effect gas emissions	-20%	-40%	-80/95%
Use of renewable energies	+20%	+27%	

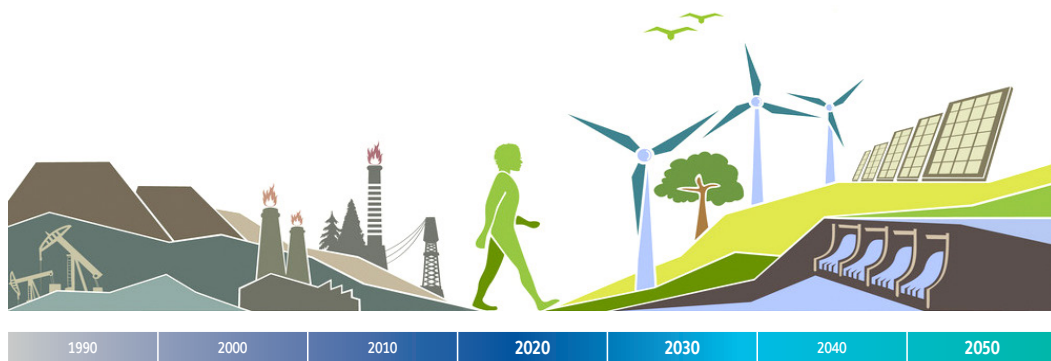

EU Energy efficiency improvement targets strongly influence the HVAC market

Buildings are the largest consumers of energy today, and HVAC systems account for a significant portion of a building's energy consumption. This is why the HVAC industry is a focus of European Environmental Policies. The F-Gas regulation addresses direct emissions while EPBD, EcoDesign and RES are directives focused on indirect greenhouse gas emissions by improving the efficiency of the HVAC systems and the buildings.

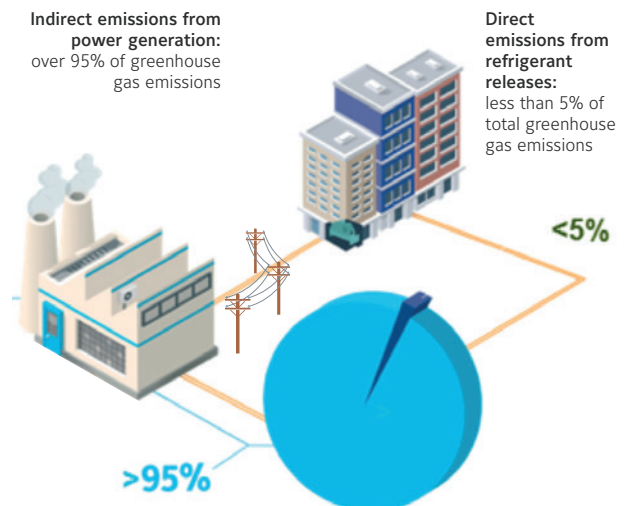
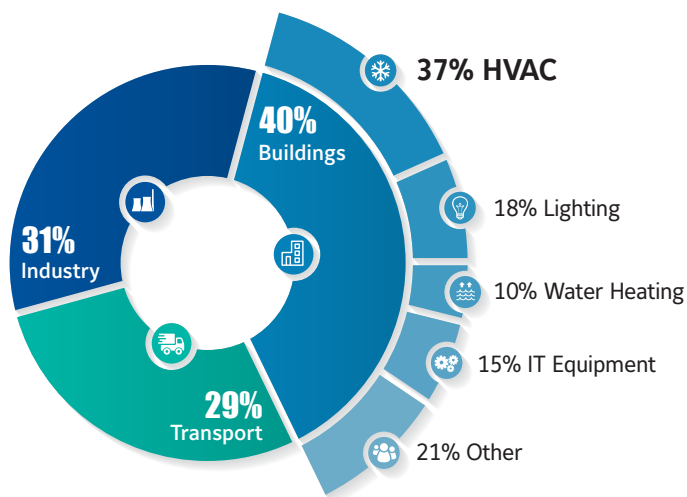

Which products are affected by Ecodesign?

The European Union has developed two directives (Ecodesign Directive 2009/125/EC and Energy Labeling Directive 2010/30/EC) to address the environmental impact of all Energy related Products (ErP) beginning at the earliest stages of design. The Ecodesign directive affects all types of Energy related Products (ErP) such as TVs, washing machines, lights and, of course, also HVAC products and components. Energy related Products (ErP) are grouped into "Lots" that, once they are published, they become mandatory CE regulations. There are three Ecodesign Lots (already approved regulations) that directly impact HVAC products.

- ENER Lot 21 ⇒ Reg 2016/2281 ⇒ Central Heating and Cooling Products (Chillers)
- ENTR Lot 1 ⇒ Reg 1095/2015 ⇒ Professional Refrigeration (Process Chillers Brine)
- ENER Lot 1 ⇒ Reg 813/2013 ⇒ Space Heaters (Heat Pumps)

Each of the three regulations set the MEPS or Minimum Efficiency Performance Standards for the product category and those are implemented in 2 steps (Tiers), as shown in the table below.

Regulation	Scope	MEPS		2015	2016	2017	2018	2019	2020	2021
		SEER	$\eta_{s,c}$				T1 Jan18			T2 Jan21
Reg 2016/2281 (former ENER Lot 21)	Comfort Chillers	SEER	$\eta_{s,c}$				T1 Jan18			T2 Jan21
	High Temperature Process Chillers	SEPR _{HT}								
Reg 1095/2015 (former ENTR Lot 1)	Medium Temperature Process Chillers	SEPR _{MT}			T1 Jul16		T2 Jul18			
Reg 813/2013 (former ENER Lot 1)	Heat Pumps	SCOP	$\eta_{s,h}$	T1 Oct15		T2 Oct17				

Calculations according to Transitional Methods that indicates the Harmonized EN standards to use (EN14511, EN14825 mainly).

Ecodesign has changed the way we speak

Former full efficiency ratios like EER and COP are now disappearing. Even the seasonal efficiency ratio ESEER has been replaced. Ecodesign MEPS are the current key indicators used for all HVAC product and compliance is mandatory to have the CE marking. The Eurovent organization is already using Ecodesign MEPS at the different certification programs are not using ESEER value anymore.

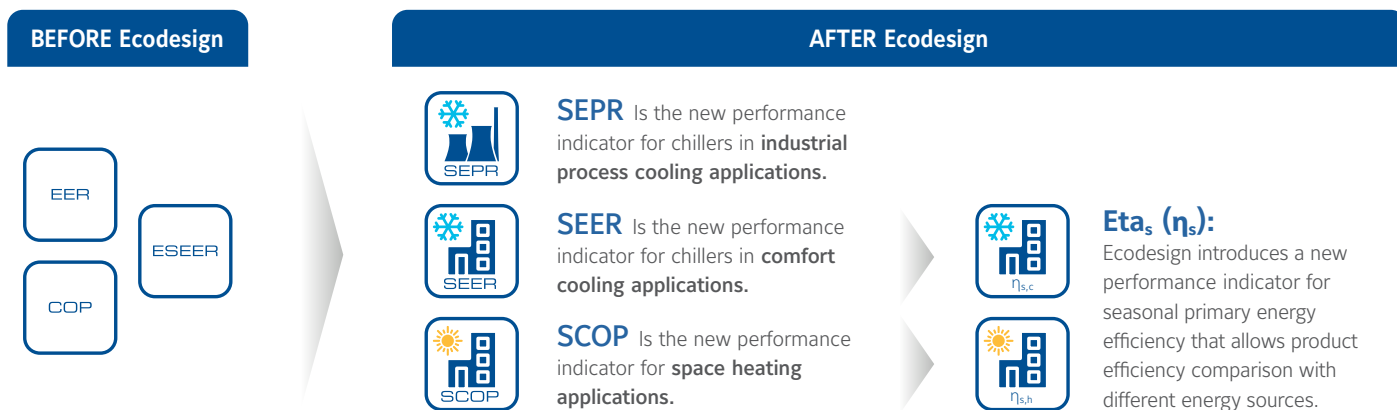

Calculation method

An important point that must be specified on the manufacturers rating report is the calculation method regarding the water flow and outlet temperature. According regulation there are four possible methods.

FW/FO = Fixed Water Flow, Fixed Outlet Temperature
FW/VO = Fixed Water Flow, Variable Outlet Temperature

VW/FO = Variable Water Flow, Fixed Outlet Temperature
VW/VO = Variable Water Flow, Variable Outlet Temperature

- Variable Outlet allows to change the leaving water temperature at partial load. This reduces the lift required by the chiller, reducing energy use significantly. To provide this rating, chillers must be capable of automatic water temperature reset based on outdoor ambient temperature. With this capability, even projects without advanced building control systems can benefit.
- Variable Flow reduces energy use at part load through reduced waterside pressure drop. Variable Speed Pumps must be fitted to the system to benefit from this savings.
- It is important to note that efficiencies can vary hugely depending on the temperatures and the method of calculation.
- **It is crucial to check the chilled water conditions used to determine the SEER, SEPR and SCOP when comparing the seasonal energy efficiency.**

Regulation 2016/2281 Comfort Cooling



Ecodesign regulation 2016/2281 affects Comfort Cooling Chillers with rated cooling capacity below 2,000 kW with a leaving water temperature equal or larger than 2°C. It's divided into two sub-categories based on the chiller water temperature. Manufacturers must provide a technical datasheet, called a fiche, with the equipment to detail the application(s) in compliance.

Low temperature chillers

Chillers that provide water to fan coil or air handling units using 12 to 7°C as entering and leaving temperatures for the efficiency calculation.

Medium temperature chillers

Chillers that provide water, for instance to cooling floors or chilled beams, using 23 to 18°C as entering and leaving temperatures for the efficiency calculation.

SEER - Seasonal Energy Efficiency Ratio

Ecodesign regulation introduces new Minimum Energy Performance Standards for Comfort Cooling Chillers (SEER) that it's the ratio between the annual cooling demand and the annual electrical input energy over the entire cooling season.

SEER is calculated using standard EN14825, which takes the following into account:

- Seasonal efficiency while the compressor is running (SEERon)
- Electrical consumption when the compressor is not running: crankcase heater, standby or OFF mode

SEER is a better performance indicators for cooling than former ESEER, as it takes into account temperature bins and hours based on weather data from a reference city at central Europe (Strasbourg).

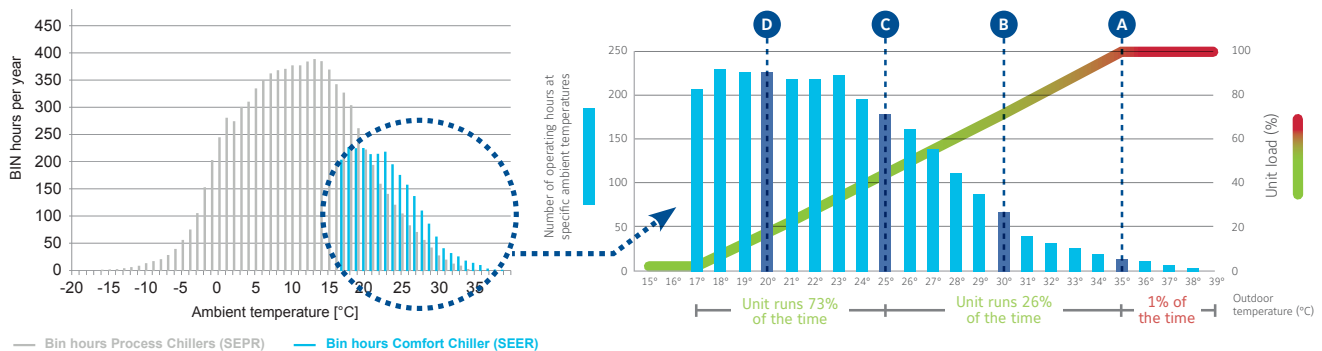

According to the standard EN14825 the number of operating hours for a comfort chiller is 2602h (only 29.7% of the total year hours).

Efficiency requirements set by REGULATION 2016/2281 Comfort Cooling

Regulation 2016/2281 sets seasonal energy efficiency in Etas cool ($\eta_{s,c}$). This value expresses SEER in terms of primary energy and it makes it possible to compare the energy efficiency of units using different energy sources. In Europe, on average 2.5 kW of primary energy is required to generate 1kW of electricity and therefore the next formulas and values are used for the conversion.

$$\eta_{s,c}(\%) = 1/CC \times SEER - \sum F_i$$

CC - Conversion Coefficient

European average coefficient that represents the amount of primary energy required to obtain electricity. CC is defined by the regulation with a constant value of 2,5.

$\sum F_i$ - Correction Factors

- Air-cooled chillers $\sum F_i = 3\%$
- Water-cooled chillers $\sum F_i = 3\%$

Comfort Chillers	Tier 1 (Jan 2018)		Tier 2 (Jan 2021)	
	$\eta_{s,c}$ %	SEER	$\eta_{s,c}$ %	SEER
Air cooled < 400 kW	149	3.80	161	4.10
Air cooled 400 to 2000 kW	161	4.10	179	4.55
Water cooled < 400 kW	196	4.98	200	5.08
Water cooled 400 to 1500 kW	227	5.75	252	6.38
Water cooled 1500 to 2000 kW	245	6.20	272	6.88

No cooling efficiency requirement is defined by Ecodesign for heat pumps (regulation 813/2011) or for medium temperature industrial or for process chillers (regulation 1095/2015).

Regulation 2016/2281 High Temperature Process Chillers



Regulation 1095/2015 Medium Temperature Process Chillers



Ecodesign regulation 2016/2281 also applies to High Temperature Process Chillers with rated cooling capacity below 2,000 kW for industrial process applications. High temperature chillers are capable of delivering leaving water temperatures of between 2°C and 12°C. In addition regulation 1095/2015 affects any capacity Process Chillers operating at design capacity that can generate outlet fluid temperature of -8°C (Medium Temperature).

SEPR - Seasonal Energy Performance Ratio

Ecodesign regulation 2016/2281 and 1095/2015 introduces a new indicator called Seasonal Energy Performance Ratio (SEPR), which is the ratio of annual cooling demand to annual electrical energy consumption.

SEPR is calculated from an average climate reference with ambient temperature ranging from -19°C up to 38°C, and with corresponding operating hours at each temperature bin. For Process cooling the operating load ranges from 100% down to 80%.

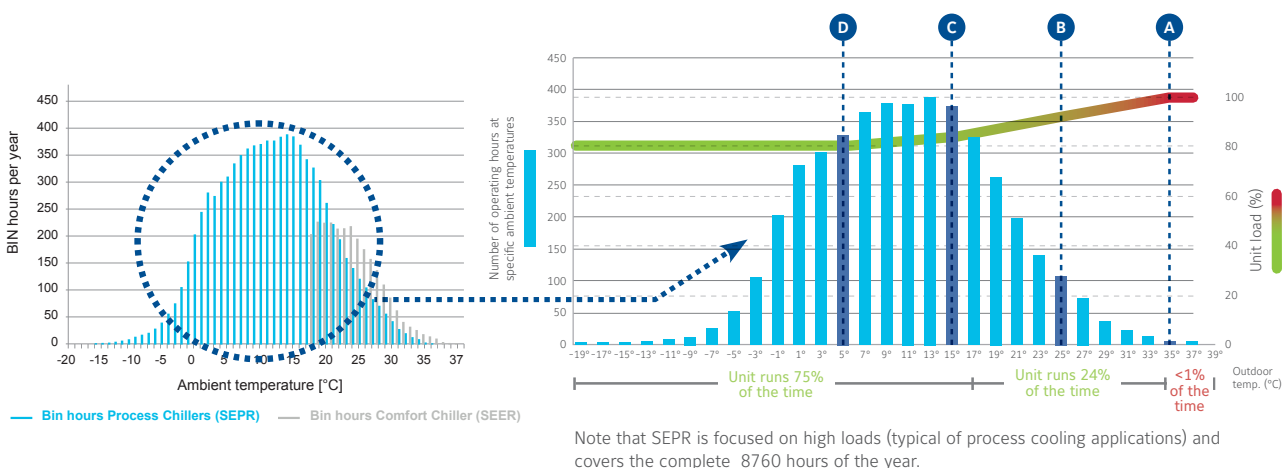

Note that SEPR is focused on high loads (typical of process cooling applications) and covers the complete 8760 hours of the year.

Efficiency requirements set by REGULATION 2016/2281 High Temperature Process Chillers

Regulation 2016/2281 sets minimum efficiency levels for positive leaving water temperature chillers (high temperature chillers) rated up to 2,000 kW used in industrial process cooling applications.

There is no SEPR_{HT} requirement for chillers and heat pumps that apply to other regulations.

High Temperature Process Chillers	Tier 1 (Jan 2018) / SEPR _{HT} (12/7°C)	Tier 2 (Jan 2021) / SEPR _{HT} (12/7°C)
Air cooled < 400 kW	4.50	5.00
Air cooled 400 to 2000 kW	5.00	5.50
Water cooled < 400 kW	6.50	7.00
Water cooled 400 to 1500 kW	7.50	8.00
Water cooled 1500 to 2000 kW	8.00	8.50

Efficiency requirements set by REGULATION 1095/2015 Medium Temperature Process Chillers

Regulation 2015/1095 sets minimum efficiency levels for chillers with negative leaving water temperature used in industrial process cooling applications. Medium temperature process chillers are defined as units capable of operating at -8°C leaving temperature.

Chillers that applies to this regulation (SEPR_{MT}) are excluded to the other Ecodesign regulations (like 2016/2281)

Medium Temperature Process Chillers	SEPR - 1st July 2016		SEPR - 1st July 2018	
	SEPR _{MT} (GWP > 150)	SEPR _{MT} (GWP < 150)	SEPR _{MT} (GWP > 150)	SEPR _{MT} (GWP < 150)
Air cooled < 300 kW	2.24	2.02	2.58	2.32
Air cooled > 300 kW	2.80	2.52	3.22	2.90
Water cooled < 300 kW	2.86	2.57	3.29	2.96
Water cooled > 300 kW	3.80	3.42	4.37	3.93

Regulation 813/2013 Space Heaters



Published regulation 813/2013 affects all Heat Pumps (both air and water cooled) with a rated heating output below 400 kW (measured at -10°C ambient)

It relates to units used for space heating application that supply hot water and covers two sub-categories based on the leaving water temperature: medium temperature and low temperature.

YORK heat pump units affected by this regulation are classified as Low Temperature because heating outlet fluid temperature can not be supplied at 52°C (measured at -7°C ambient). **"Low-temperature application" means an application where the heat pump space heater delivers its declared capacity for heating at an indoor heat exchanger outlet temperature of 35°C**

SCOP- Seasonal Coefficient of Performance

Ecodesign regulation 813/2013 introduces a new indicator called Seasonal Coefficient of Performance (SCOP), which is the ratio between the annual heating demand and the annual electrical input energy over the entire heating season.

SCOP is calculated using standard EN14825, which takes the following into account:

- Seasonal efficiency while the compressor is running (SCOPon)
- Electrical consumption when the compressor is not running: crankcase heater, standby or OFF mode
- Backup heater required to achieve the defined heating design load

SCOP takes into account the energy efficiency achieved at each outdoor temperature of an average climate weighted by the number of BIN hours for each of those temperatures.

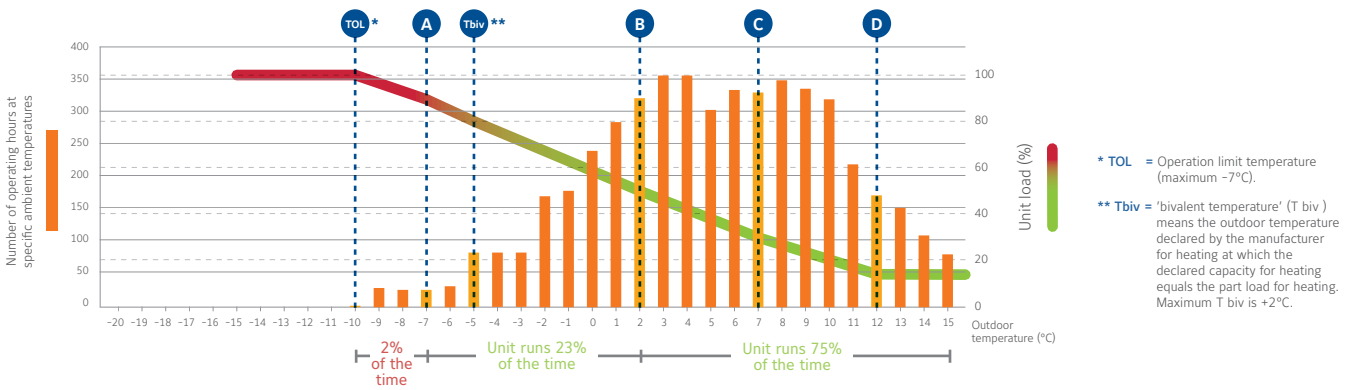

The number of operating hours for a heat pump covered by SCOP is **4910h (56% of the total year hours)**.

Efficiency requirements set by REGULATION 813/2013 – Heat Pumps

Regulation 813/2013 sets seasonal energy efficiency in $\eta_{s,h}$ heat. This value expresses SCOP in terms of primary energy and it makes it possible to compare the energy efficiency of units using different energy sources.

$$\eta_{s,h}(\%) = 1/CC \times SCOP - \sum F_i$$

CC = Conversion Coefficient = 2.5

$\sum F_i$ = Correction Factor

Air source heat pumps = 3%

Water source heat pumps = 8%

Heat Pumps	Tier 1 (Oct 2015)		Tier 2 (Oct 2017)	
	$\eta_{s,h}$ %	SCOP	$\eta_{s,h}$ %	SCOP
Air to water low temperature heat pumps < 400	115	2.95	125	3.20
Water to water low temperature heat pumps < 400	115	3.08	125	3.33

Energy Labelling Regulation 811/2013

Heat Pumps with capacities below 70 kW are classified by the **European Energy Labelling regulation 811/2013** with the objective to inform to the end-user about which is the efficiency level of the heat pump acquired.



Product Information

Manufacturers are to provide to installers and end users instruction and access to a website that makes available (for free) a new "Technical Data Sheet" document summarizing the values used for the efficiency ($\eta_{s,c}$, SEPR or $\eta_{s,h}$) calculation.

Below is an example of the "Technical Data Sheet" as it appears in regulation 2016/2281:

Information requirements for comfort chillers							
Model(s): Information to identify the model(s) to which the information relates.							
Outdoor side heat exchanger of chiller: (select which: air or water/brine)							
Indoor side heat exchanger chiller: (default: water)							
Type: compressor driven vapour compression or sorption process							
If applicable: driver of compressor: (electric motor or fuel driven, gaseous or liquid fuel, internal or external combustion engine)							
Item	Symbol	Value	Unit	Item	Symbol	Value	Unit
Rated cooling capacity	$P_{rated,c}$	x,x	kW	Seasonal space cooling energy efficiency	$\eta_{s,c}$	x,x	%
Declared cooling capacity for part load at given outdoor temperature T_j				Declared energy efficiency ratio or gas utilisation efficiency/auxiliary energy factor for part load at given outdoor temperature T_j			
$T_j = +35^\circ\text{C}$	P_{dc}	x,x	kW	$T_j = +35^\circ\text{C}$	$\frac{EER_d \text{ or } GUE_{c,bin}}{AEF_{c,bin}}$	x,x	%
$T_j = +30^\circ\text{C}$	P_{dc}	x,x	kW	$T_j = +30^\circ\text{C}$	$\frac{EER_d \text{ or } GUE_{c,bin}}{AEF_{c,bin}}$	x,x	%
$T_j = +25^\circ\text{C}$	P_{dc}	x,x	kW	$T_j = +25^\circ\text{C}$	$\frac{EER_d \text{ or } GUE_{c,bin}}{AEF_{c,bin}}$	x,x	%
$T_j = +20^\circ\text{C}$	P_{dc}	x,x	kW	$T_j = +20^\circ\text{C}$	$\frac{EER_d \text{ or } GUE_{c,bin}}{AEF_{c,bin}}$	x,x	%
Degradation coefficient for chillers (*)	C_{dc}	x,x	-				
Power consumption in modes other than "active mode"							
Off mode	P_{OFF}	x,xxx	kW	Crankcase heater mode	P_{cc}	x,xxx	kW
Thermostat off mode	P_{TO}	x,xxx	kW	Standby mode	P_{SB}	x,xxx	kW
Other items							
Capacity control	fixed / staged / variable			For air-to-water comfort chillers: air flow rate, outdoor measured	-	x	m ³ /h
Sound power level, outdoor	L_{WA}	x,x/x,x	dB	For air-to-water comfort chillers: air flow rate, outdoor measured	-	x	m ³ /h
Emissions of nitrogen oxides (if applicable)	NO_x (**)	x	mg/kWh input GCV				
GWP of the refrigerant			kg CO ₂ eq (100 years)				
Standard rating conditions used: (low temperature application/medium temperature application)							
Contact details	Name and address of the manufacturer or of its authorised representative						

(*) If C_{dc} is not determined by measurement then the default degradation coefficient of chillers shall be 0.9.
(**) From 26 September 2018

General Information:
Unit name, Air/Water cooled, type compressor

Mode "On" information:
Capacity, efficiency at different temperatures for partial load points A,B,C and D

Mode "Off" information:
Power input Auxiliaries (crankcase heater, stand-by mode, etc)

Other information:
Sound, GWP, flow rates, application:
• Floor heating/fancoils
• Fancoils/Chilled beams

Compliance

All YORK products on the EU market comply with applicable Ecodesign regulations. In many cases YORK products offer significantly better energy efficiency than required by regulation, resulting in an attractively low cost of operation and lighter environmental footprint.



Air Handling Systems and Terminal Devices

Air Handling Units

Rooftop equipment

Fan Coil Units

Close Control Units

Factory Fitted Controls

Your tailored AHU solution: From fully customized to compact standard

We recognise that your reputation depends on the quality of the products you choose and how well they are installed. That's why we work hard to make selecting, installing and operating our products as easy as possible. Our comprehensive range includes a number of additional options that make YORK Air Handling Units the professional's choice.

YORK Air Handling Units & Indoor Air Quality Options

CUSTOMIZED



YMA
Customized
Airflow range:
1,000-200,000 m³/h



SEMI-CUSTOMIZED



YMB
Semi-Customized
Airflow range:
700-100,000 m³/h

STANDARD



YMD
Standard
Airflow range:
1,000-112,000 m³/h



SWIMMING POOLS



YMB-SP
Swimming Pools
Airflow range:
1,000-45,000 m³/h

PACKAGED HEAT PUMP



YMF-S/R/H/F
Packaged Heat Pump
Airflow range:
1,500-24,500 m³/h



COMPACT



YBV-NG...S NEW
Compact - Suspended
Counter-flow Plate Heat
Exchanger
Airflow range:
150-3,300 m³/h



YBV-NGA...C NEW
Compact - Floor Mounted
Rotary or counter-flow
Plate Heat Exchanger
Airflow range:
690-8,000 m³/h



YBV-NG...C NEW
Compact - Top
Counter-flow Plate Heat
Exchanger
Airflow range:
1,250-4,000 m³/h

COMPACT



YKR
Compact
Rotary Heat Exchanger
Airflow range:
600-10,600 m³/h



YKC NEW
Compact
Counter-flow Plate Heat Ex.
Airflow range:
1,500-7,360 m³/h



YKL
Compact
Counter-flow Plate Heat Ex.
Airflow range: 65-620 m³/h

RESIDENTIAL



YKH
Residential
Counter-flow Plate Heat Ex.
Airflow range: 65-620 m³/h



YKH-2G NEW
Heat Recovery Ventilation Unit
Counter-flow Plate Heat Ex.
Airflow range: 150-600 m³/h
Energy class A/A+

YORK Air Handling Units flowchart

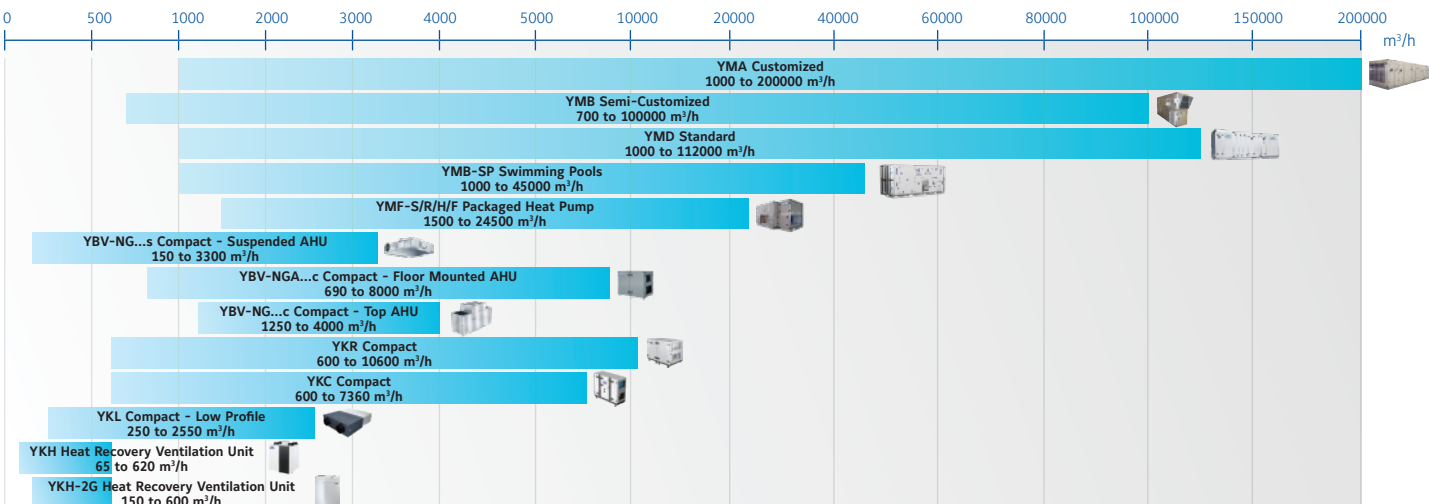

Introducing the YMA range of Air Handling Units



The YORK YMA range encompasses our extensive knowledge of air-handling, offering a highly reliable, economical and energy efficient product capable of addressing all of your needs.

Features

The YMA family of air handling units consists of a range of models having air volumes ranging from 1.000 - 200.000 m³/h and total static pressures as high as 2000 Pascal: to ensure maximum flexibility and the best solution for your application, units are available in increments of 40mm in height and 50mm in width.

YMA Air Handling Units can be manufactured in varied configurations, with a wide selection of components, to meet customer requirements. Units are also available in line with the requirements of hospital sector specifications.

Dimensional flexibility. Space constraints are a reality on most construction projects. YORK AHU's design is based on variable aspect ratios, so the unit can be specified to fit the application and space.

Material flexibility. Different environments require different materials so we offer a number of construction materials, including galvanized steel, pre-coated steel, stainless steel, and aluminium.

Component flexibility. To meet any AHU requirement, our units offer every available air-handling component. And as applicable technology creates new capabilities, Johnson Controls will apply this to our product range.

Over the past 50 years we have supplied air handling units for:

- **Commercial space:** office buildings, cinemas, concert halls
- **Institutional space:** schools, universities, churches
- **Industrial manufacturing:** automotive, aerospace, chemical, petrochemical
- **Hygienic systems:** hospitals, life sciences, R&D facilities, food processing, clean rooms
- **Process manufacturing:** pharmaceutical, electronics, semiconductor

Equipment Life Cycle. Each YMA unit has a designated suffix ('S', 'T', or 'R') that identifies the factory of origin. This makes it easier to identify and locate production and technical data to assist in advising on spare parts, as well as supporting the customer with any post installation modifications or upgrades that may be requested during the life of the unit.

YMA Custom Air Handling Units

A complete range from 1,000 m³/h – 200,000 m³/h



Features

The YMA family of air handling units consists of a range of models having air volumes ranging from 1,000 – 200,000 m³/h and total static pressures as high as 2,000 Pascal: to ensure maximum flexibility and the best solution for your application, units are available in increments of 40mm in height and 50mm in width.

YMA Air Handling Units can be manufactured in varied configurations, with a wide selection of components, to meet customer requirements.

Units are also available in line with the requirements of hospital sector specifications.



Units may include combinations of any of the following:

- Single or double decked units.
- Indoor or outdoor applications – Outdoor units are available with a flat or sloping roof, louvres, rainhoods, birdscreens and special finishes.
- Site assembled units.
Where space constraints restrict the size of a single item modules can easily be aligned and locked together by gaskets and stainless steel bolts inserted into factory predrilled assembly holes.
- Air mixing boxes and various filter options.
- Gas fired burners.
- Cooling and heating coils.
- Humidifiers
- Heat recovery systems.
- UV sterilising lamps.
- Dessicant and thermal wheels.
- Sound attenuation.
- ATEX Certification.
- Factory fitted controls and sensors.
These include all necessary piping, wiring, controls and refrigeration equipment to provide a complete central air conditioning plant.
- Hygienic construction option for hygiene sensitive environments.

The Frame

- Low weight, corrosion resistant, marine aluminium alloy twin box section profile, designed to provide strength and stability
- Gaskets between the frameworks' panels and profiles, to allow efficient cleaning and prevent trapping and harmful bacteria growth
- Optional thermal bridge free profile
- Unit sections mounted on a 3mm thick galvanized steel bolted base frame

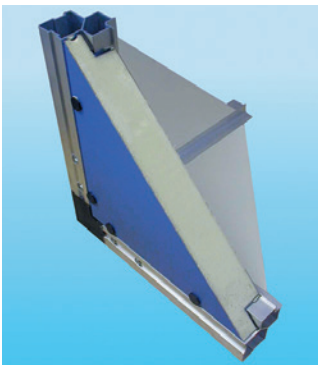

Standard Construction

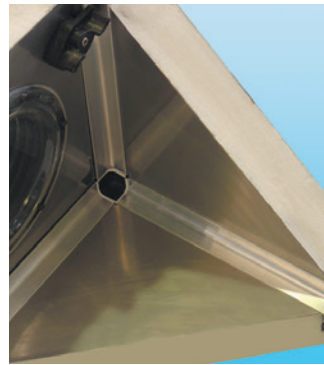

Cold Bridge Free Construction



Panels

- Standard 60mm thick (40mm optional) double skinned galvanized panels
- 0.7mm internal and external skins with 40kg/m³ density pressure injected polymerised polyurethane foam insulation
- Returned "K" value of 0.2W/m²°C
- Optional panels manufacturing from pre-plastic coated steel, pre-painted metal or stainless steel
- Mineral wool infill panel of 100kg/m³ density available
- 88mm panels available upon request

Access

- Fully removable panels
- Access doors equipped with half turn nylon handles and cam locks
- Fibreglass reinforced plastic hinges with stainless steel pivots
- Double glazed viewing portholes (optional)

Mechanical characteristics- EN 1886:2009

EUROVENT DIPLOMA 08.05.289 YMA (T), 09.11.443 YMA (R), 05.02.314 YMA (S) APPLIES

Model	Casing Strength Class	Casing Air Leakage Class at 400 Pa	Casing Air Leakage Class at 700 Pa	Thermal Leakage Class	Filter Bypass Transmittance Class	Thermal Bridging Factor Class
PU6055ST	D1(M)	L1(M)	L1(M)	F9(M)	T2	TB3
PU6040TB	D1(M)	L1(M)	L1(M)	F9(M)	T1	TB2
RW6055ST	D2(M)	L2(M)	L2(M)	F9(M)	T2	TB3
RW6055TB	D1(M)	L1(M)	L2(M)	F9(M)	T2	TB2
PU6055TB	D1(M)	L1(M)	L1(M)	F9(M)	T1	TB2



Manufacturer reserves the rights to change specifications without prior notice.

YMB

Semi-Customized Air Handling Units

A complete range from 700 m³/h – 100,000 m³/h

Building and indoor climate requirements are constantly evolving. They can be influenced by many factors: energy legislation, occupancy churn, lighting, IT infrastructures... all important reasons that highlight the need for reliable, efficient Air Handling units.

Suitable for use in either new building developments or upgrades and refitting of existing buildings, our **YMB** range of AHU is a range of modular, Fixed Aspect Ratio units designed with efficiency and cost in mind to meet the needs of more 'commercial' installations.

Our knowledge, flexibility and commitment to the customer address four primary requirements of building owners and designers—efficiency, flexibility, sustainability, and confidence.



YMBS/YMBD Semi-Customized Air Handling Unit characteristics

Available sizes	21	
Airflow range (m ³ /h)	700 ~ 100 000	
Application	<ul style="list-style-type: none"> • housing and retail construction industry • public utility buildings • industrial facilities construction • leisure facilities 	
Basic options	<ul style="list-style-type: none"> • G4 class filters • F5, F7, F9 class filters • heat recovery • water/steam/glycol/electric heater • water/glycol/freon cooler • humidification, fan and attenuation section 	
Additional options	<ul style="list-style-type: none"> • sub-assemblies manufactured as explosion-proof • swimming pool version • hygienic version • YORK Factory Fitted Controls 	
Heat recovery	<ul style="list-style-type: none"> • recirculation • cross-flow heat exchanger • rotary heat exchanger 	<ul style="list-style-type: none"> • heat pipe • glycol recovery system • heat pump
Installation type	<ul style="list-style-type: none"> • indoors (YMBS) / outdoors (YMBD) 	

YMB is available for indoor installation called YMBS and outdoor installation called YMBD



YMBS/YMBD performances

YMBS/YMBD*				
Unit size	Airflow range [m³/h]	Width B	Height H1	Height H2
Insulation 50 mm				
MINI	700 - 1800	640	490	980
1	1000 - 3000	650	600	1200
2	2600 - 4100	700	700	1440
3	3900 - 6100	940	700	1440
4	6000 - 9400	940	1010	2020
1	1000 - 3000	690	640	1280
2	2600 - 4100	740	740	1480
3	3900 - 6100	980	740	1480
3-BIS	5000 - 8000	1290	740	1480
4	6000 - 9400	980	1050	2100
5	8000 - 12600	1290	1050	2100
6	9600 - 15100	1290	1250	2500
5-BIS	11000 - 17000	1580	1050	2100
6-BIS	1200 - 21000	1580	1250	2500
7	13500 - 21300	1580	1370	2740
7-BIS	18000 - 28000	1885	1370	2740
8	21300 - 33700	1885	1670	3340
9	26000 - 41000	1885	2020	4040
8-BIS	30000 - 46000	2400	1670	3340
10	34000 - 53000	2400	2020	4040
8A-BIS	38000 - 59000	3000	1670	3340
11	43000 - 69000	2400	2500	5000
10-BIS	46000 - 71500	3000	2020	4040
12	57000 - 90000	3000	2500	5000
12-BIS	68000 - 100000	4800	2020	-

* YMBD is only in 50 mm thick insulation available (optionally, YMBS and YMBD in 70 mm thick insulation)

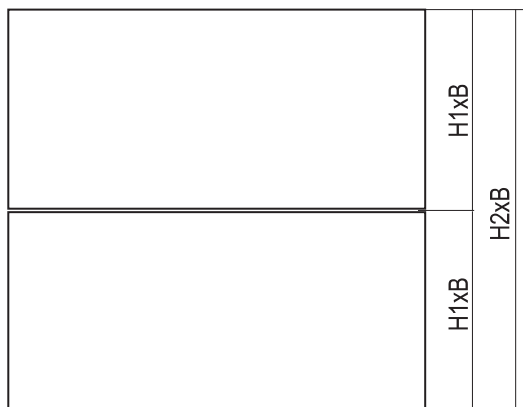

YMBS/YMBD



YMB range is DIN1946-4 certified

YMD Standard Air Handling Units

A complete range from 1,000 m³/h to 112,000 m³/h



Designed to ensure total control of temperature, humidity and air quality

The new **YORK YMD Standard Air Handling Units** ensure the highest performances with the lowest running cost, being optimized based on the specific application.

The best comfort on wide ambients, even with high attendance: YORK YMD Air Handling Units ensure the full control on overall room climate, managing temperature, humidity, oxygenation and air cleanliness.

APPLICATIONS

- Schools and Universities
- Cinemas and Theaters
- Shopping Malls
- Airports
- Hospitals
- Multifunctional Buildings
- Offices
- Sport Centres and Swimming Pools

In **Industrial Processes** they ensure the control of precise parameters of air quality, cleanliness and sanification.

- Pharmaceutical Industry
- Laboratories
- Textile Industry
- Food Industry
- Plastic Industry
- Mechanical Industry



The best comfort on wide ambients and the highest performance with the lowest running cost.

YMD key features

The YMD offer a wide range of configurations: double-deck, side-by-side, in-line supply/exhaust, in-line 2-way mixing and in-line 3-way mixing supply/exhaust.

Dampers

- Aluminium dampers with aerodynamic profile
- Dedicated gaskets for excellent tightness and integrated gear for higher protection
- Motorisable



Leakproof, maximum performance

- Snap-in system and perfect sealing on sections avoid air leakages
- Accurate sealing on filter frames prevent filter by-passing to ensure optimum air treatment

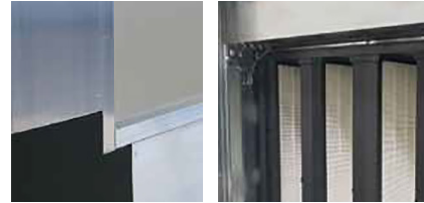

Structure

- Steel base and aluminium frame
- Structure also available with thermal break profiles and with smooth interiors for sanitary applications



Free-Cooling

- On special conditions of external and internal air temperature, it ensures the air treatment with maximum energy efficiency
- It allows to bypass the heat recovery, through direct inlet of external air properly treated
- It allows to exclude the heat exchangers, at the same time ensuring an optimal air treatment
- The Free-Cooling operation can be managed to be electronically managed by the Integrated Electronic Control through a system of sensors (option)

Panels

- Double skin sandwich side panels with 25-50-63 mm thickness (on different profiles)
- 25 and 50 mm panels are fixed with exclusive SNAP-IN system (screwfree) ensuring even pressure on the casing for excellent air tightness



Easy maintenance

- All components are easily removable for cleaning and replacement
- Full access to all sections for cleaning
- Hinged doors, portholes for internal inspection, interior lighting
- Coils extractable on guides
- Filters extractable on guides or frames

Integrated Control

Integrated Electronic Control also available with sensors for monitoring ambient conditions and unit's status, with consequent regulation of the unit itself and its components:

- Activates cooling, heating, post-heating coils and humidifiers
- Manages dampers and heat recoveries, with eventual Free-Cooling activation
- Provides feedback about filters' alarms
- Visualises eventual alarms
- Adjusts airflow through fans management



Manufacturer reserves the rights to change specifications without prior notice.

YMD main sections

Wide choice of sections with several technologies and performance levels. Units are available with different power supply, voltage and frequency (50/60 Hz).

Ventilation

- Plug-Fans or Radial fans with forward or backward curved blades
- EC Inverter control also available for higher efficiency
- Compliant to ErP EcoDesign 2018 Directive



Heat Recovery

- Cross-flow plate heat exchangers, Counter-flow plate heat exchangers, Rotary heat exchangers (condensation, enthalpic, sorption) or Run-around coils
- Compliant to ErP EcoDesign 2018 Directive



Cooling/Heating

- Water, steam or direct expansion coils for cooling, heating, dehumidification, pre/post-heating

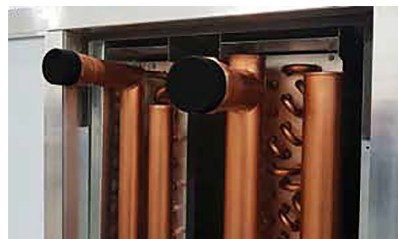

Filtration

- Filters of any type and efficiency level: panel, compact, bag filters
- Absolute HEPA type filters up to H14 class
- Dedicated carbon filters to remove odours
- Accurate sealing on filter frames prevent filter by-passing to ensure perfect air treatment
- All filters are removable and fixed on guides or frames
- Compliant to ErP EcoDesign 2018 Directive, EN779 - ISO16890

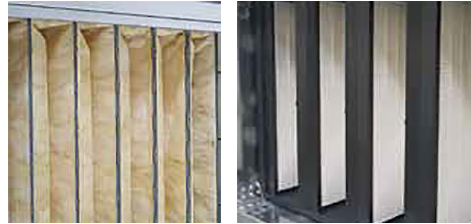

Humidification

- Sprayed atomized water, steam or media pad humidifiers
- The humidifier can be coupled with a droplet eliminator



Silencers

- High efficiency mineral wool silencing sections with various performance levels available
- Also available with cleanable materials



YMB-SP

Air Handling Unit for private and public swimming pools

A complete range from 1,000 m³/h to 45,000 m³/h



To satisfy any dehumidifying, heating or cooling requirement with innovative technology

Highly efficient unit designed for ventilation, dehumidification and heating of all types of indoor swimming pools – private, hotel and public – for recreational, sport and therapeutic purposes.

The YMB-SP pool unit is manufactured in various sizes providing air outputs in the range of 1,000–45,000 m³/h. Construction materials used for the construction as well as internal components for air processing and pumping are characterised by increased resistance to corrosion and chlorine compounds.

Equipping swimming pool units with a heat pump significantly increases the heat recovery coefficient and makes it possible to dehumidify the air in summer periods when supplying 100% fresh air does not ensure maintenance of the required humidity. An additional advantage of using a heat pump in a swimming pool unit is the possibility of recovering heat from the exhaust air and transferring it to heating the pool water.



Comfortable air handling in private and public swimming pools, at maximum energy efficiency.

Main product features

- The control panel is highly resistant to corrosion and chlorine compounds
- Internal elements of Magnelis ZM310 (e.g. frame and diaphragm of the fan unit, filter guides)
- Heat pump fittings made of copper alloys
- High-efficiency AC or EC fans
- 50 mm or 70 mm thick mineral wool insulation
- The device is tailored and selected to the individual needs of the customer
- Optional: Heat pump increasing the heat recovery coefficient and ensuring significant savings

 **AIRFLOW RANGE**
1000 - 45000 m³/h

14 STANDARD SIZES

UP TO **92%** HEAT RECOVERY EFFICIENCY

Designed to maintain an efficient and safe climate

Appropriate construction of YMB-SP pool units ensures failure-free operation in conditions more difficult than air-conditioning of daily life, as the units treat both fresh air and process (mainly dehumidifying) air extracted from the pool hall, which is very humid and contains aggressive chlorine compounds.

A skeleton construction is used in the YMB-SP pool units, which consists of aluminium profiles and corners forming a skeleton structure to which covers, removable panels and inspection doors are attached. The interior floor sheathing and internal components, including the frame and diaphragm of the fan unit, filter guide, diaphragms and exchanger guides. The sheathing consists of an external sheet metal (aluzinc) and an internal sheet metal (galvanised sheet metal coated on both sides) filled with 50 mm or 70 mm thick mineral wool insulation.

The floor is made of coated galvanised sheet metal. The exchanger guides, filters, diaphragms and all fixing elements are made of coated galvanised sheet metal. The same type of sheet metal is used for the casing of the drop separator and the tub.

- ① HIGHLY EFFICIENCY HEAT PUMP
- ② CORROSION-RESISTANT STRUCTURE
- ③ MULTI-STAGE HEAT RECOVERY SYSTEM
- ④ DESIGNED FOR DEHUMIDIFICATION AND VENTILATION OF ALL TYPES OF INDOOR SWIMMING POOL HALLS



Manufacturer reserves the rights to change specifications without prior notice.

YMF

Packaged Air Handling Unit with Heat Pump

A complete range from 1,500 m³/h to 24,500 m³/h



The high efficiency recovery units with integrated heat pump circuit have been designed and created for commercial and industrial applications and combine the need for air recirculation with maximum energy saving, thanks to the adoption of very high efficiency components.

YMF-S

Heat recovery unit with high efficiency modulating heat pump circuit and counter-flow heat recovery from 1500 to 23000 m³/h

- Very high recovery efficiency
- Reduced energy consumption
- Separate flow plate recovery unit suitable for hospital use
- Integration with the most common supervision systems
- Easy to install

YMF-R

Heat recovery unit with modulating heat pump circuit and very high efficiency enthalpy rotary recovery from 1500 to 24500 m³/h

- Very high recovery efficiency and reduced energy consumption
- Humidity recovery with the rotary wheel
- Integration with the most common supervision systems
- Easy to install

YMF-H

Heat recovery unit with high efficiency modulating heat pump circuit and plate heat recovery from 1500 to 24000 m³/h

- High recovery efficiency and reduced energy consumption
- Separate flow plate recovery unit suitable for hospital use
- Integration with the most common supervision systems
- Easy to install

YMF-F

Heat recovery unit with high efficiency modulating heat pump circuit and plate heat recovery from 300 to 4000 m³/h

- High recovery efficiency and reduced energy consumption
- Indoor (false ceiling) and outdoor (with roof) installation
- Integration with the most common supervision systems
- Compactness and ease of installation
- Integration of "ALL-IN-ONE" functions (air recirculation and heat treatment)

Absolute Heat Recovery Unit with Heat Pump

These are independent units destined to changing the air at neutral temperatures (that is at the same temperatures present inside the room to be treated, in both summer and winter) and to the thermal treatment of the air.

According to the external ambient conditions (external air and room extract air) the units may even cover – partially or totally – the winter/summer thermal loads, depending on the characteristics of the building and its use.

YMF-S

Heat recovery unit with modulating heat pump circuit
Very high efficiency plate heat recovery from 1 500 to 23 000 m³/h



YMF-R

Heat recovery unit with modulating heat pump circuit
Very high efficiency enthalpy rotary heat recovery from 1 500 to 24 500 m³/h



YMF-H

Heat recovery unit with modulating heat pump circuit
High efficiency plate heat recovery from 1 500 to 24 000 m³/h

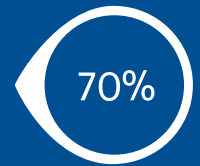

YMF-F

Heat recovery unit with modulating heat pump circuit
High efficiency plate heat recovery from 300 to 4 000 m³/h

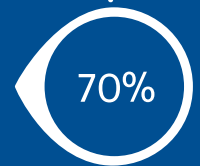

HEAT RECOVERY EFFICIENCY



Manufacturer reserves the rights to change specifications without prior notice.



YBV-NG Compact Suspended Air Handling Units

A complete range from 150 m³/h to 3,300 m³/h



High efficiency compact ventilation units with heat recovery for commercial applications

The YBV Next Generation Compact air handling units are the new YORK range of energy saving ventilation units with a high efficiency energy recovery up to 90%.

The suspended YBV-NG Compact air handling units are equipped with a counter-flow hexagonal recuperator, EC motors, Mini-Pleat filters and integrated automation (Plug&Play) and they have a capacity from 150 m³/h to 3300 m³/h.

YORK YBV-NG units are suitable for operation in balanced or slightly unbalanced flow and return conditions. They ensure commercial air exchange, recovering the heat from the extracted air and conveying it to the clean air.

 **AIRFLOW RANGE**
150 - 3300 m³/h

5 **STANDARD SIZES**

UP TO 90% **HEAT RECOVERY EFFICIENCY**



MINERAL WOOL INSULATION



HIGHLY EFFICIENT HEX COUNTER-FLOW HEAT RECOVERY



ENERGY SAVING AND SILENT FANS WITH EC MOTORS



PLUG&PLAY PRODUCT

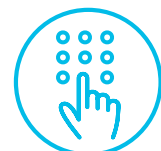

INTEGRATED MULTIFUNCTIONAL CONTROLS

ADDITIONAL AIR TREATMENT FUNCTIONS



Mini-Pleat
air filter



Bag filter



Heater



Cooler

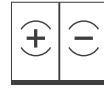

Heater, Cooler



Sound
attenuator



Additional
empty space



Base unit overall data

Unit size	Nominal airflow (m ³ /h)	Airflow range (m ³ /h)	Height (mm)	Width (mm)	Duct connection height (mm)	Duct connection width (mm)
YBV-NG005s	500	150 - 650	400	790	318	335
YBV-NG010s	1000	300 - 1100	400	1150	318	515
YBV-NG015s	1500	450 - 1650	400	1550	318	715
YBV-NG020s	2000	600 - 2200	490	1610	408	743
YBV-NG030s	3000	900 - 3300	490	2160	408	1018

Section length

Unit size					
	Base unit	Additional air treatment functions			
	(mm)	(mm)	(mm)	(mm)	(mm)
YBV-NG005s	1230	200	200 - 460	370 - 460	460 - 920
YBV-NG010s	1500	200	200 - 460	370 - 460	460 - 920
YBV-NG015s	1500	200	200 - 460	370 - 460	460 - 920
YBV-NG020s	1828	200	200 - 460	370 - 460	460 - 920
YBV-NG030s	1828	200	200 - 460	370 - 460	460 - 920

Duct accessories

Type	Dimension WxH [mm]				
	YBV-NG005s	YBV-NG010s	YBV-NG015s	YBV-NG020s	YBV-NG030s
Flexible connection	305x288	485x288	685x288	730x375	1005x375
Air damper	305x288	485x288	685x288	730x375	1005x375
Rectangle spigot	330x310 / 300x300	510x310 / 400x350	710x310 / 400x350	740x400 / 500x400	1015x400 / 800x400
Rounded spigot	330x310 / 355	510x310 / 355	710x310 / 355	740x400 / 450	1015x400 / 450



Manufacturer reserves the rights to change specifications without prior notice.

YBV-NG Compact Suspended Air Handling Units

CASING

- Panels filled with mineral wool, enclosed with steel sheet on both sides.
- Casing parameters according to EN 1886: T2, TB3, L1, D1, F9.

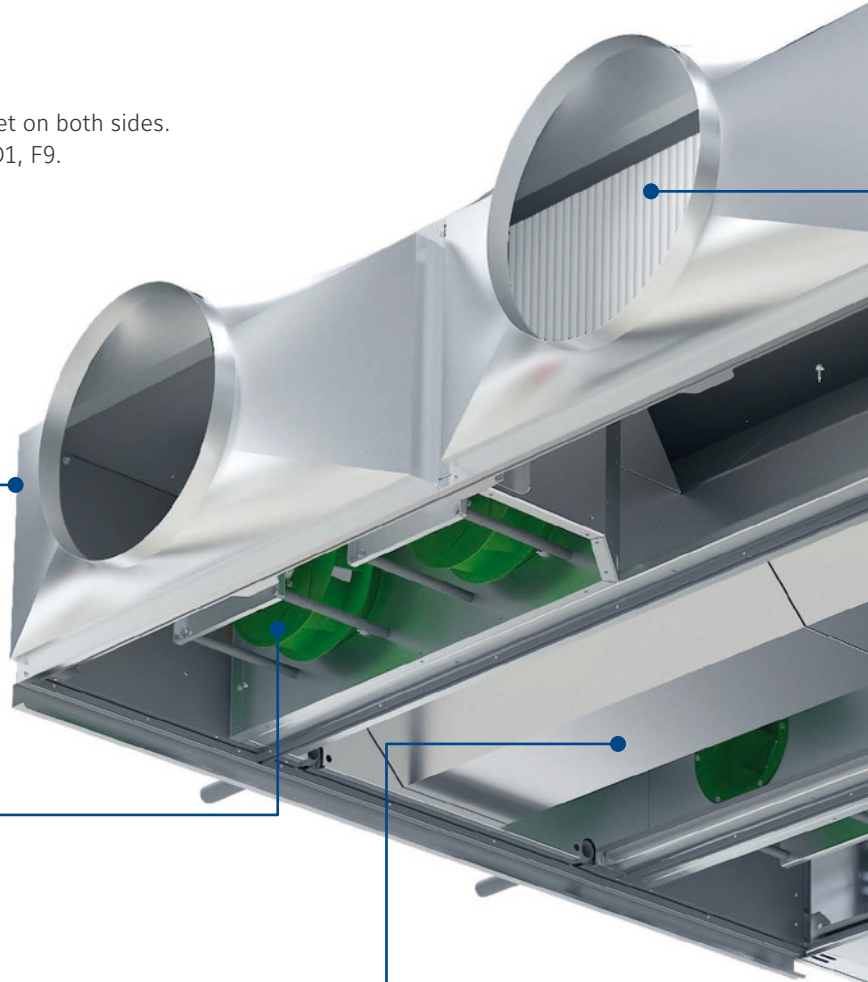
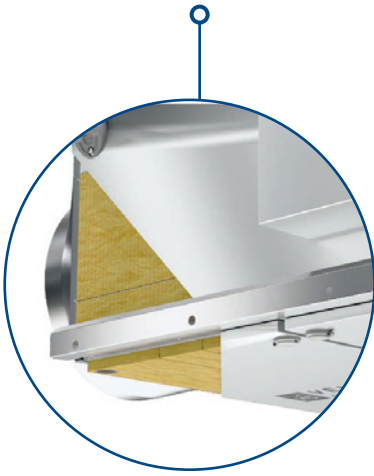

UP TO
93%
DRIVE EFFICIENCY



EC MOTORS

- Efficient, silent and low vibrations fan with electronically commutated motor in a IE4 class.

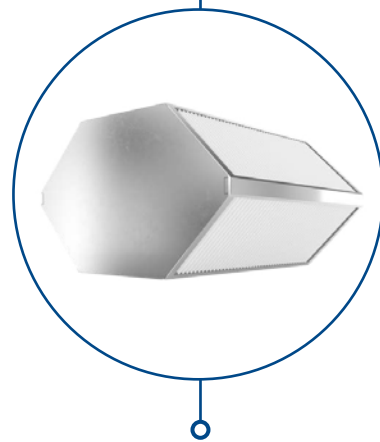

ENERGY RECOVERY

- Highly efficient counterflow hex recovery with by-pass.
- Recovery efficiency reaching 90%.

MINI-PLEAT FILTERS

Air filters with extended high efficiency filtration surface.

- Supply - EU7 (ePM2,5 65%)
- Exhaust - EU5 (ePM10 50%)

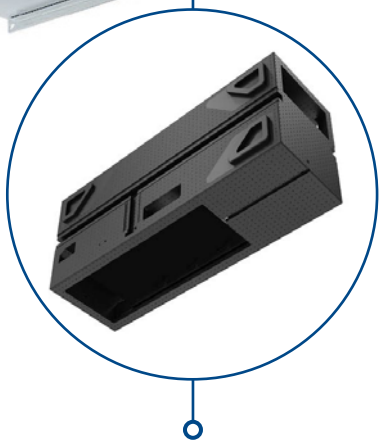
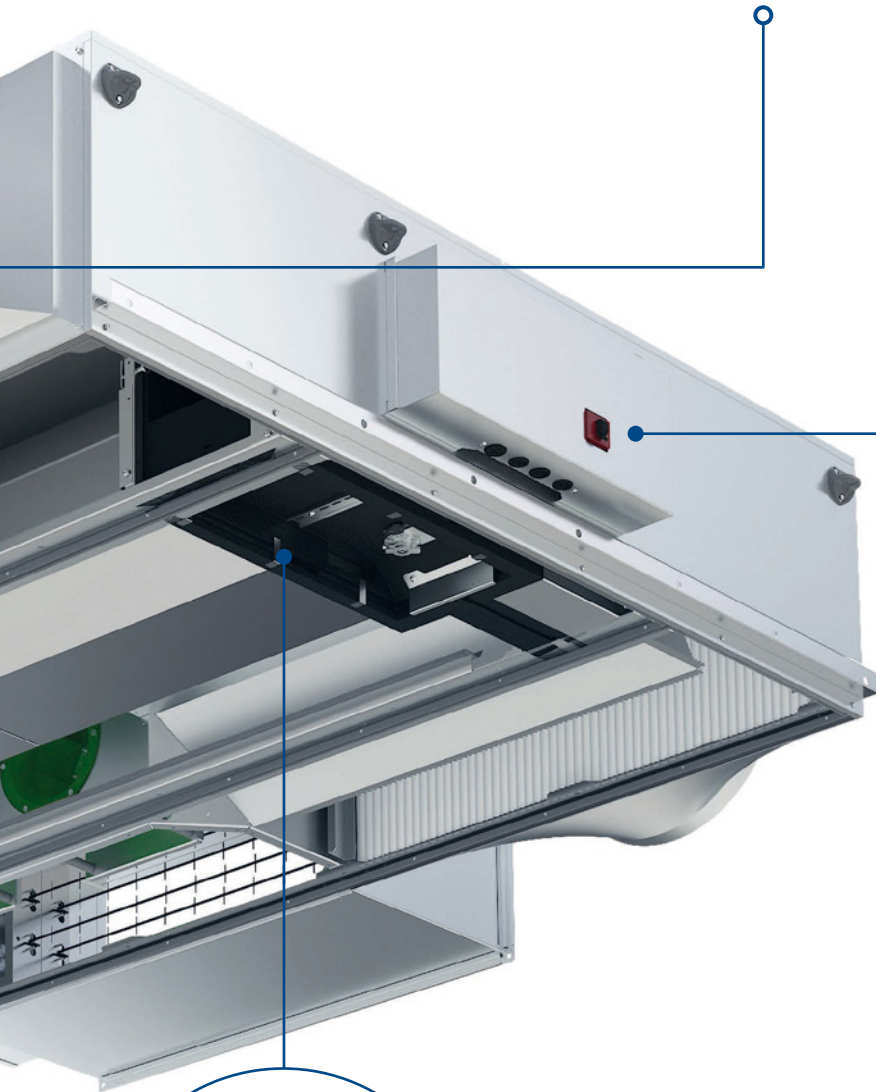

RECUPERATOR BY-PASS

- Stepless adjustment of heat recovery capacity.
- Passive cooling function.
- Recuperator frost protection.

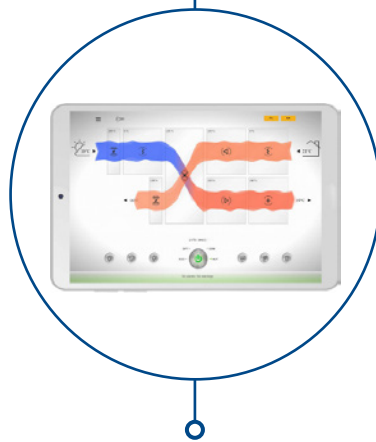

CONTROLS

- Multifunctional controls, integrated with the unit – fully pre-configured and ready to run.



YBV-NG Compact Floor Mounted Air Handling Units

A complete range from 690 m³/h to 8,000 m³/h



High efficiency compact ventilation units with heat recovery for commercial applications

The YBV Next Generation Compact air handling units are the new YORK range of energy saving ventilation units with a high efficiency energy recovery up to 90%. The compact design and ease of maintenance of these units make them ideal where space is limited.

The new range of compact air handling units is equipped with rotary heat recovery units or counterflow heat recovery units, with a heat recovery efficiency of up to 90%. In addition, all models come with silent fans with a high-efficiency EC motor.

The new YBV-NG Compact floor mounted range, with a capacity from 690 m³/h to 8000 m³/h, is also equipped with electric resistance of different power ranges depending on the size of the unit, and integrated multifunctional controls, configured and ready for commissioning.

YORK YBV-NG units are suitable for operation in balanced or slightly unbalanced flow and return conditions. They ensure air exchange, recovering the heat from the extracted air and conveying it to the clean air.

 AIRFLOW RANGE
690 - 8000 m³/h

11 STANDARD
SIZES

UP TO **90%** HEAT RECOVERY
EFFICIENCY

Main Advantages

COMPACT CASING:

- Casing material – Magnelis® (magnesium-zinc coating)
- Mineral wool insulation – panel thickness: 50 mm
- Mechanically poured gasket

HIGH EFFICIENCY:

- Rotary heat exchanger: condensing or sorption
- HEX counterflow heat exchanger: aluminium
- Highly efficient fan sets with electronically commutated (EC) motors

COMPACT SIZE:

- Ability to move the unit through a 900 mm door
- Air handling unit base configuration: heat recovery, fan sets, filters, heater (optional)
- Number of sections:
 - Sizes YBV-NG 11-22 RRG and HEX – one section
 - Sizes YBV-NG 29-56 RRG – two sections
 - Sizes YBV-NG 29-40 HEX – three sections

EASY TO MAINTAIN AND CLEAN:

- Access to the unit from both sides
- Easy access for cleaning fan sets and heat exchangers

CONTROLS:

- Multifunctional controls integrated with the unit
 - configured and ready to operate (Plug&Play)

Casing parameters compliant with EN1886 standard	Class
Thermal bridging	TB2
Thermal transmittance	T2
Casing air tightness	L1
Mechanical properties	D1
Filter tightness	F9



PANELS

- Panels made of mineral wool, double-sided coated with metal sheet with zinc-magnesium coating – Magnelis®
- Corrosion class: C5
- Panel thickness: 50 mm
- Thermal insulation: mineral wool



POURED GASKET

- High tightness of inspection panels achieved through the use of a poured gasket
- Continuity of the gasket along the entire length
- Microbiological neutrality



EASY TO MAINTAIN AND CLEAN

- Easy access to panel components
- Adjustable roller pressure ensures that the panels remain sealed during the life of the air handling unit

BENEFITS of Magnelis®

- Exceptional corrosion resistance – magnesium in the coating forms a stable protective layer on the steel surface, allowing long-term protection in harsh environments
- Self-repairing properties – the presence of magnesium supports coating regeneration
- Environmentally friendly – reduced zinc content

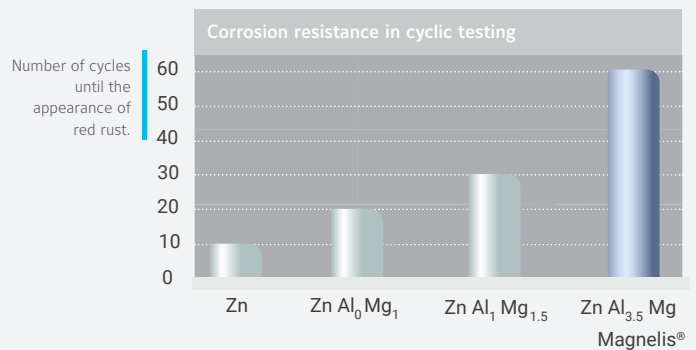

10 µm of coating submitted for an alternated cycling of 8 hours fog cycle (5% NaCl) / dry cycle / humidity cycle. Source: ArcelorMittal Global R&D

Air Handling Units with rotary heat exchanger



UP TO

90% HEAT RECOVERY
EFFICIENCY

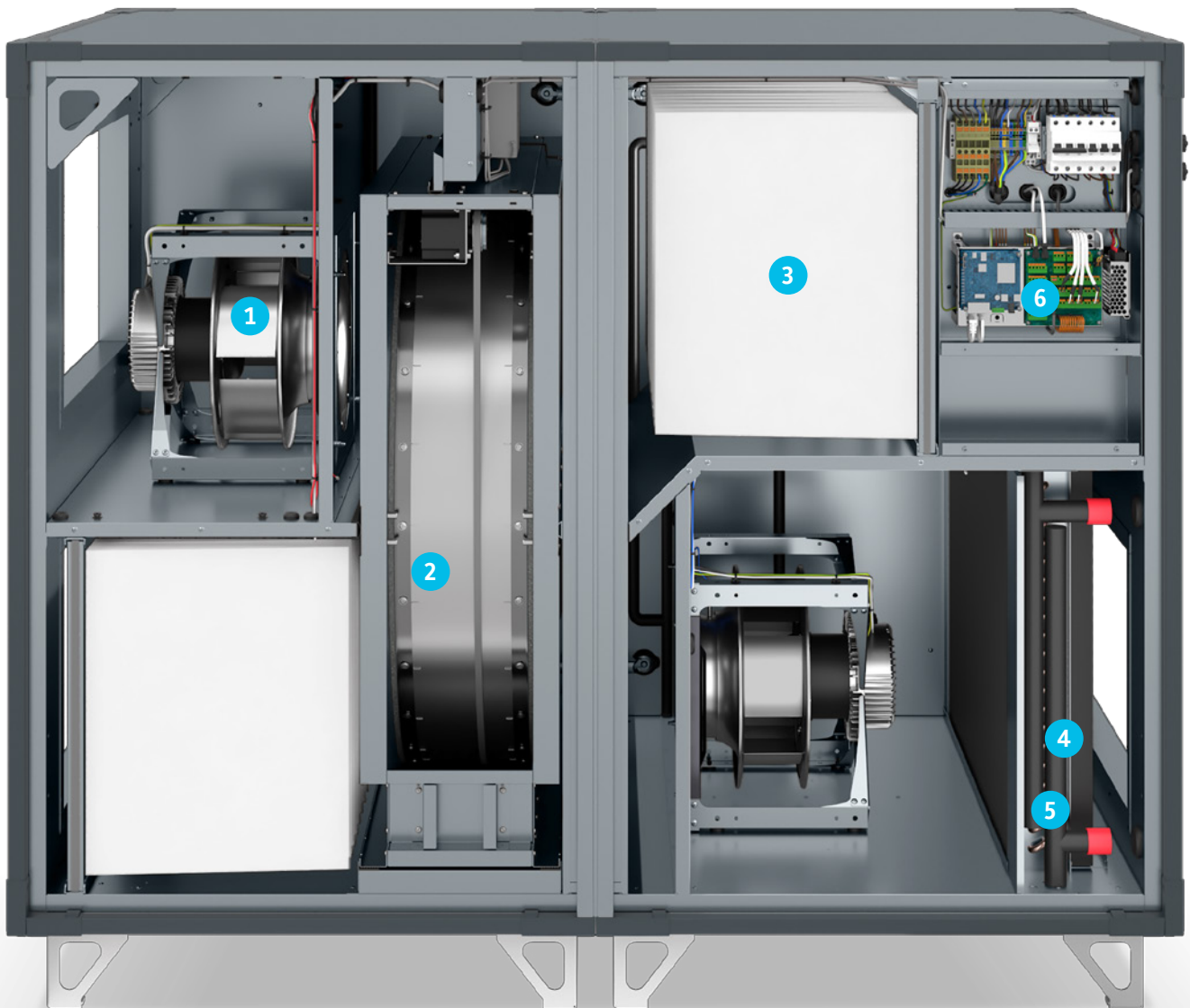

1



FAN SET

- Efficient, quiet fan with high-efficiency EC motor of IE4 class

2



ENERGY RECOVERY

- Rotary heat exchanger: condensation or sorption
- Up to 90% heat recovery efficiency
- Adjustable cleaning sector angle

3

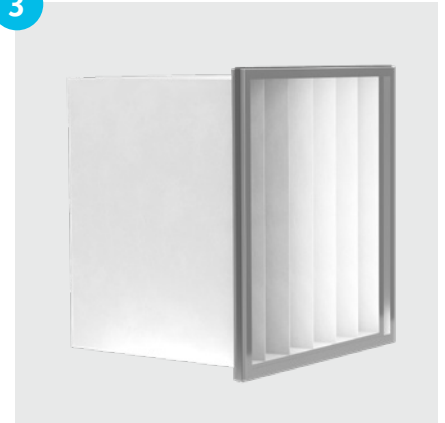

FILTERS

- Filter type - pocket filters
- Filtration class: ePM10 50% - ePM1 80%
- Gasket on the frame ensures high level of tightness

4



WATER HEATER (BUILT-IN)

- Number of rows - 1 or 2
- Easy to clean exchanger
- Easy to service

5



ELECTRIC HEATER (BUILT-IN)

- Heater power from 3 to 21 kW (depending on unit size)
- Dual protection level in the power circuit
- Smooth adjustment across the full power range
- Ease of maintenance

6

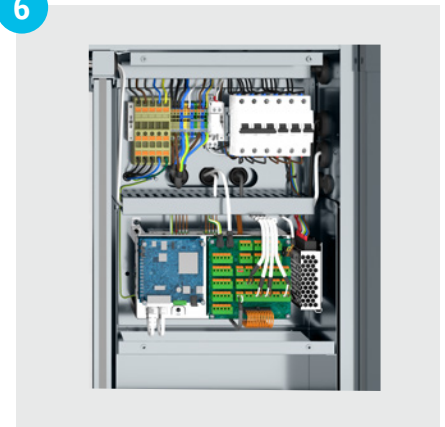

CONTROLS:

- Multifunctional controls integrated with the unit - configured and ready to operate (Plug&Play)
- Ability to connect service devices without opening the unit
- Remote servicing capability via Ethernet, Wi-Fi, Bluetooth, GSM

Air Handling Units with counterflow heat exchanger



UP TO

90% HEAT RECOVERY
EFFICIENCY

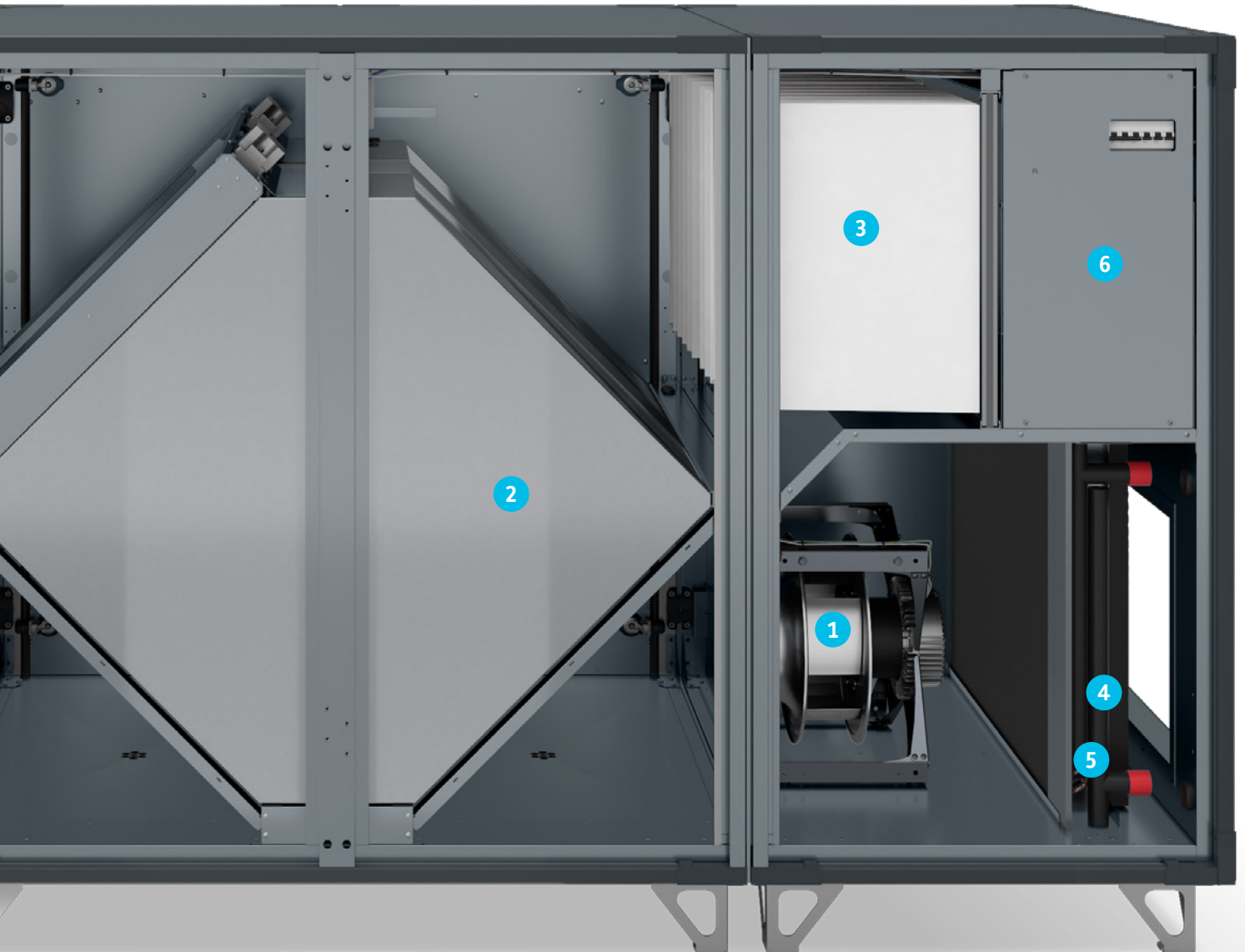

1

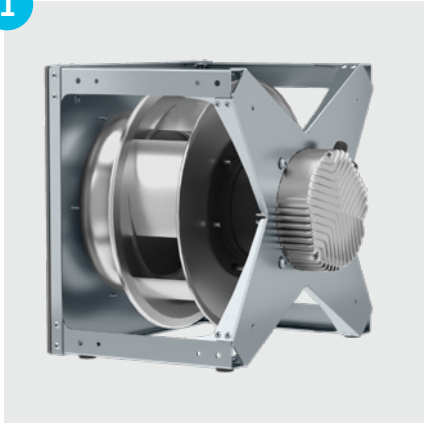

FAN SET

- Efficient, quiet fan with high-efficiency EC motor of IE4 class

2



ENERGY RECOVERY

- High efficiency hexagonal counterflow heat exchanger with bypass
- Material - aluminium
- Up to 90% efficiency
- Operating temperature range: -40°C to +90°C

3

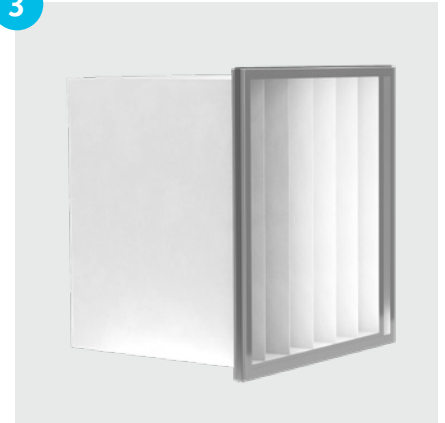

FILTERS

- Filter type - pocket filters
- Filtration class: ePM10 50%
- ePM1 80%
- Gasket on the frame ensures high level of tightness

4

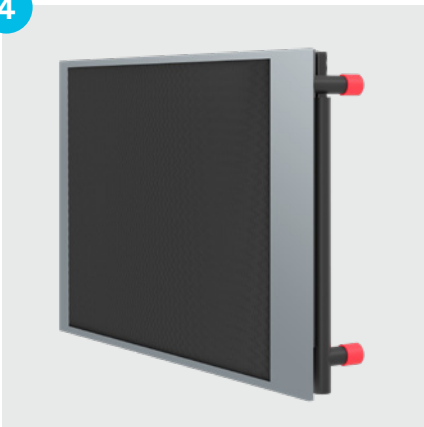

WATER HEATER (BUILT-IN)

- Number of rows - 1 or 2
- Easy to clean exchanger
- Easy to service

5



ELECTRIC HEATER (BUILT-IN)

- Heater power from 3 to 21 kW (depending on unit size)
- Dual protection level in the power circuit
- Smooth adjustment across the full power range
- Ease of maintenance

6

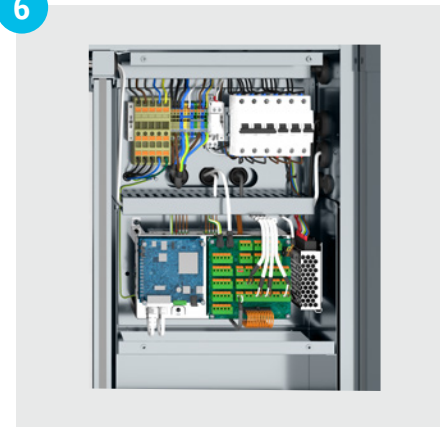

CONTROLS:

- Multifunctional controls integrated with the unit - configured and ready to operate (Plug&Play)
- Ability to connect service devices without opening the unit
- Remote servicing capability via Ethernet, Wi-Fi, Bluetooth, GSM

Air Handling Units with rotary heat exchanger

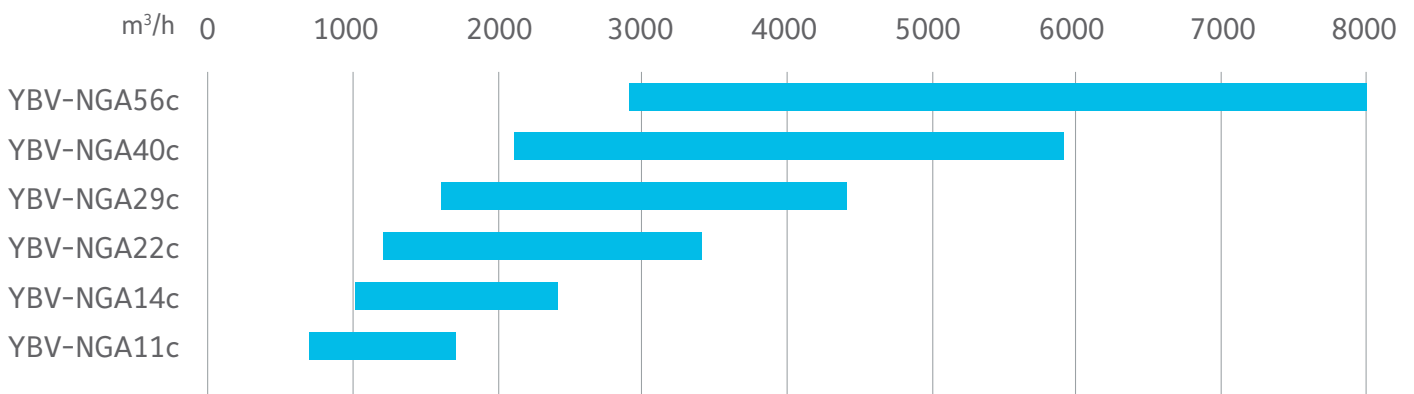
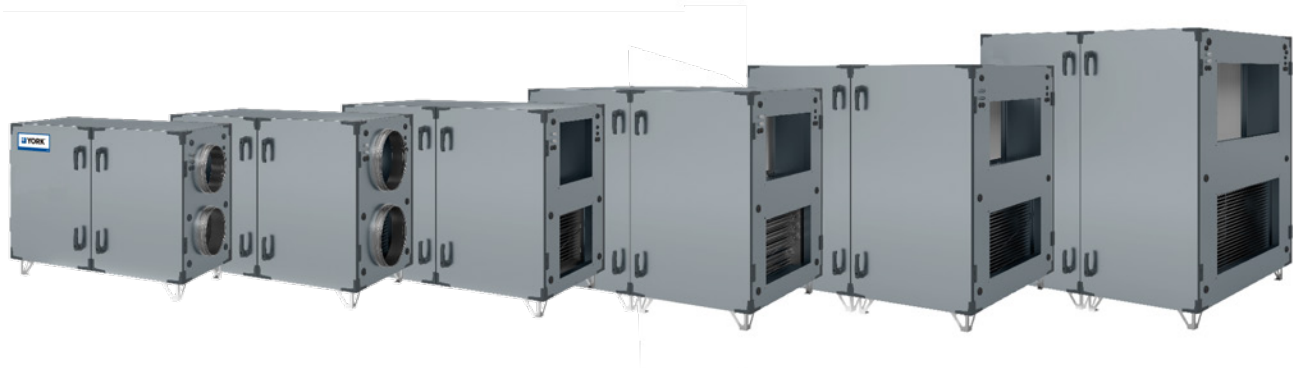

Size	Min. air flow	Max. air flow	Height *	Width	Length	Connection diameter	Connection height	Connection width	Frame height
	m³/h	m³/h	mm	mm	mm	mm	mm	mm	mm
YBV-NGA11c	680	1700	962	750	1385	315	-	-	120
YBV-NGA14c	1000	2400	1062	865	1490	400	-	-	120
YBV-NGA22c	1200	3400	1175	947	1605	-	400	500	120
YBV-NGA29c	1600	4400	1330	1124	1752	-	400	700	120
YBV-NGA40c	2100	5900	1478	1284	1752	-	400	800	120
YBV-NGA56c	2900	8000	1718	1514	1752	-	500	1000	120

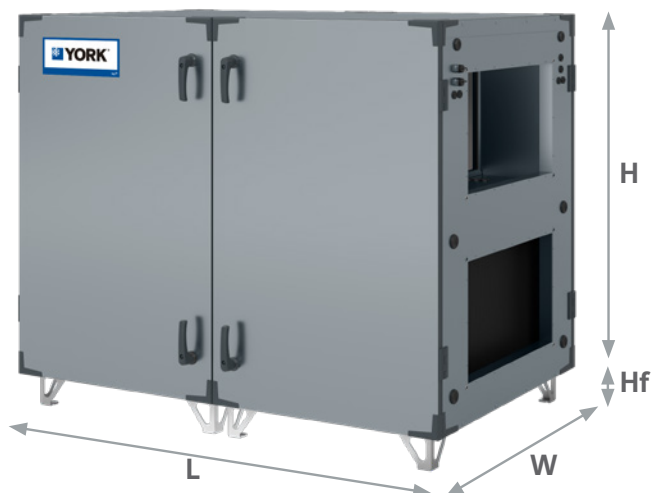

* The height of the unit does not include the height of the frame

Air Handling Units with counterflow heat exchanger

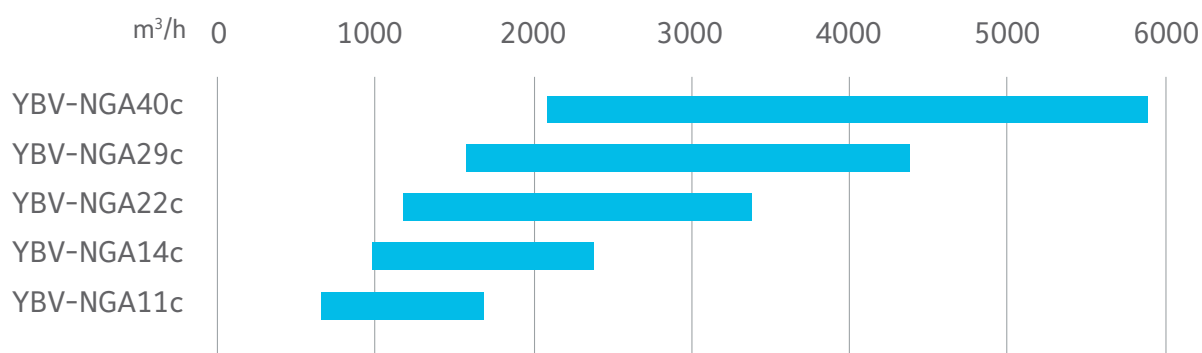

Size	Min. air flow	Max. air flow	Height *	Width	Length	Connection diameter	Connection height	Connection width	Frame height
	m³/h	m³/h	mm	mm	mm	mm	mm	mm	mm
YBV-NGA11c	680	1700	962	750	1385	315	-	-	120
YBV-NGA14c	1000	2400	1062	865	1490	400	-	-	120
YBV-NGA22c	1200	3400	1175	947	1605	-	400	500	120
YBV-NGA29c	1600	4400	1330	1124	1752	-	400	700	120
YBV-NGA40c	2100	5900	1478	1284	1752	-	400	800	120

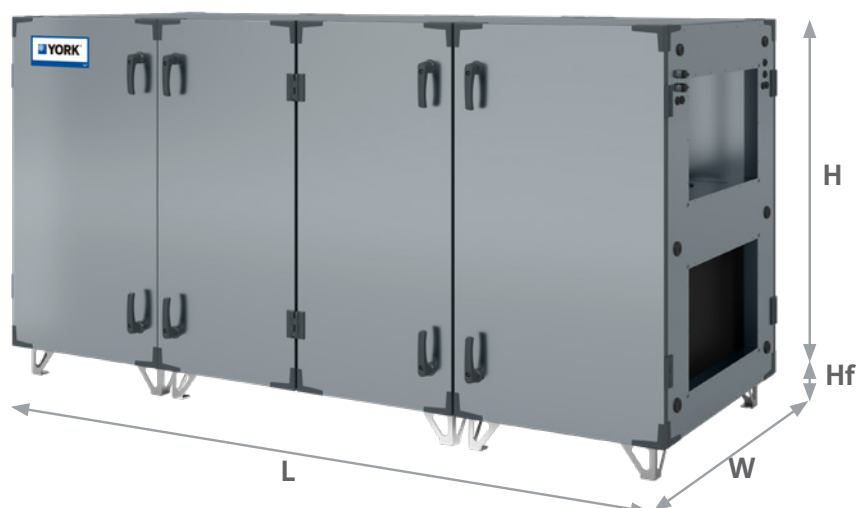

* The height of the unit does not include the height of the frame

Additional Air Handling Functions

UNITS WITH ROTARY AND COUNTERFLOW HEAT EXCHANGER

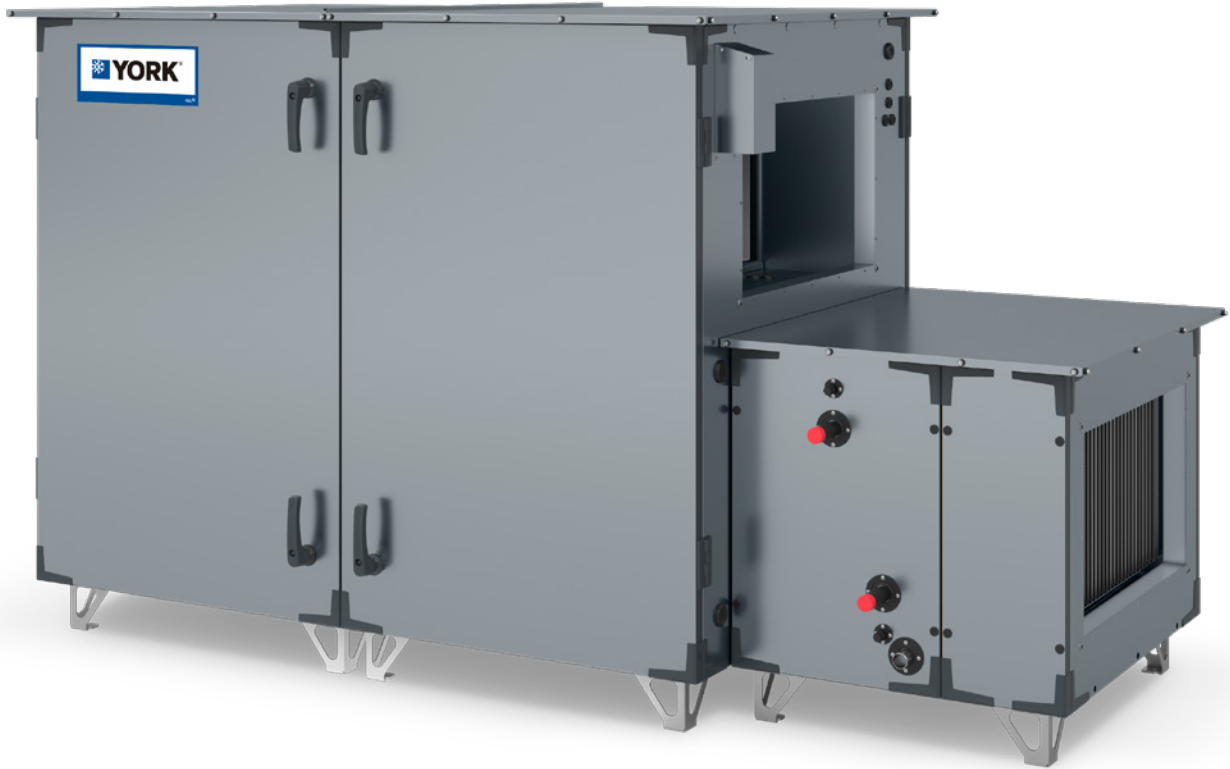

ADDITIONAL PROTECTION AGAINST EXTERNAL CONDITIONS:

- roof over base unit and extensions
- cover on air dampers actuator

Available additional features: duct silencer, freon cooler, water cooler.

			YBV-NGA11c	YBV-NGA14c	YBV-NGA22c	YBV-NGA29c	YBV-NGA40c	YBV-NGA56c
Silencer	Length	mm	300/1000	300/1000	1065	1065	1065	1065
	External width	mm	630	750	794	910	1070	1300
Freon cooler	External height	mm	410	460	584	662	736	856
	Length	mm	540	540	771	771	771	771
Water cooler	External width	mm	630	750	794	910	1070	1300
	Outside height	mm	410	460	584	662	736	856
	Length	mm	540	540	718	718	718	718

Equipment Servicing

Heat recovery system accessible from both sides for servicing and cleaning.



Connecting service equipment without opening the unit.

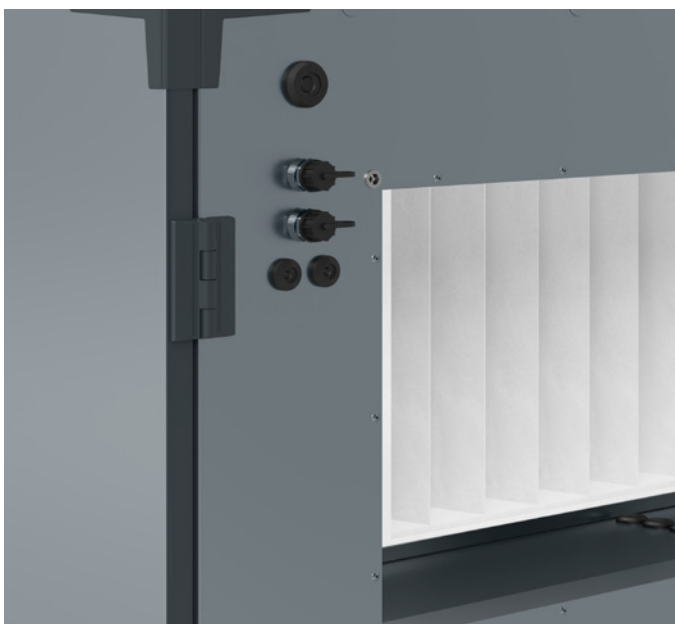

Easy disassembly of fan sets assemblies for servicing and inspection purposes.

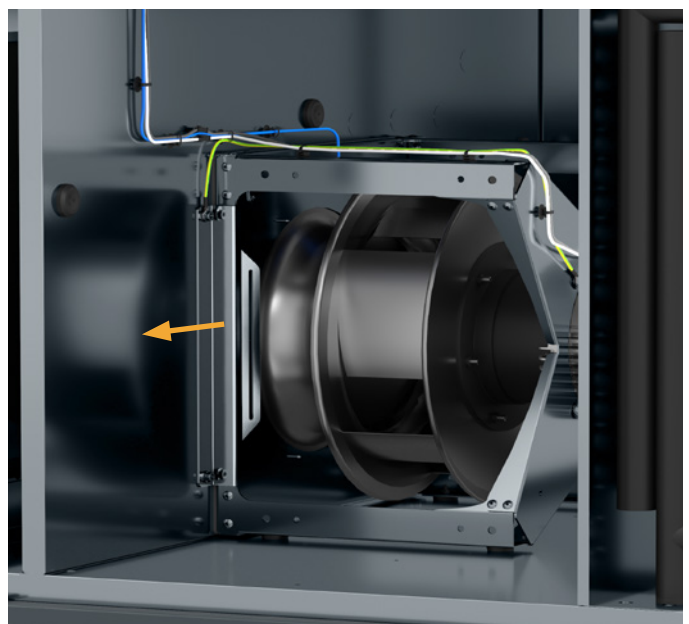



YBV-NG Compact TOP Floor Mounted Air Handling Units

A complete range from 1,250 m³/h to 4,000 m³/h



High efficiency compact ventilation units with heat recovery for commercial applications

The YBV Next Generation Compact air handling units are the new YORK range of energy saving ventilation units with a high efficiency energy recovery up to 90%.

The YBV-NG Compact TOP air handling units with vertical duct connection are equipped with a hexagonal counter-flow recuperator, EC motors, Mini-Pleat or bag filters and integrated controls in the Plug&Play standard and they have a capacity from 1250 m³/h to 4000 m³/h.

YORK YBV-NG units are suitable for operation in balanced or slightly unbalanced flow and return conditions. They ensure commercial air exchange, recovering the heat from the extracted air and conveying it to the clean air.

 **AIRFLOW RANGE**
1250 - 4000 m³/h

3 **STANDARD SIZES**

UP TO 90% **HEAT RECOVERY EFFICIENCY**

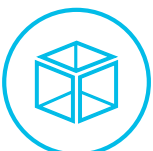

MINERAL WOOL
INSULATION

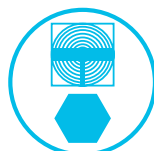

HIGHLY EFFICIENT ROTARY
AND HEX COUNTER-FLOW
HEAT EXCHANGER



ENERGY SAVING
AND SILENT FANS
WITH EC MOTORS



PLUG&PLAY
PRODUCT



INTEGRATED
MULTIFUNCTIONAL
CONTROLS

ADDITIONAL AIR TREATMENT FUNCTIONS

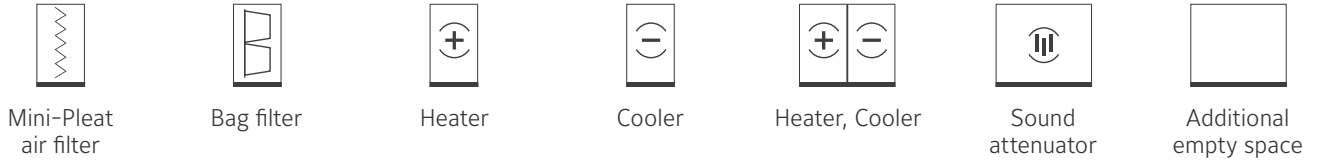

Base unit overall data

Unit size	Nominal airflow (m ³ /h)	Airflow range (m ³ /h)	Height (mm)	Width (mm)	Duct connection (mm)
YBV-NG023c	2100	1250 - 2100	1176	880	700x445
YBV-NG033c	3000	1800 - 3000	1447	880	700x513
YBV-NG043c	4000	2400 - 4000	1737	880	700x613

Base unit lengths

Unit size		
	(mm)	(mm)
YBV-NG023c	2100	2100
YBV-NG033c	2460	2460
YBV-NG043c	2860	2860

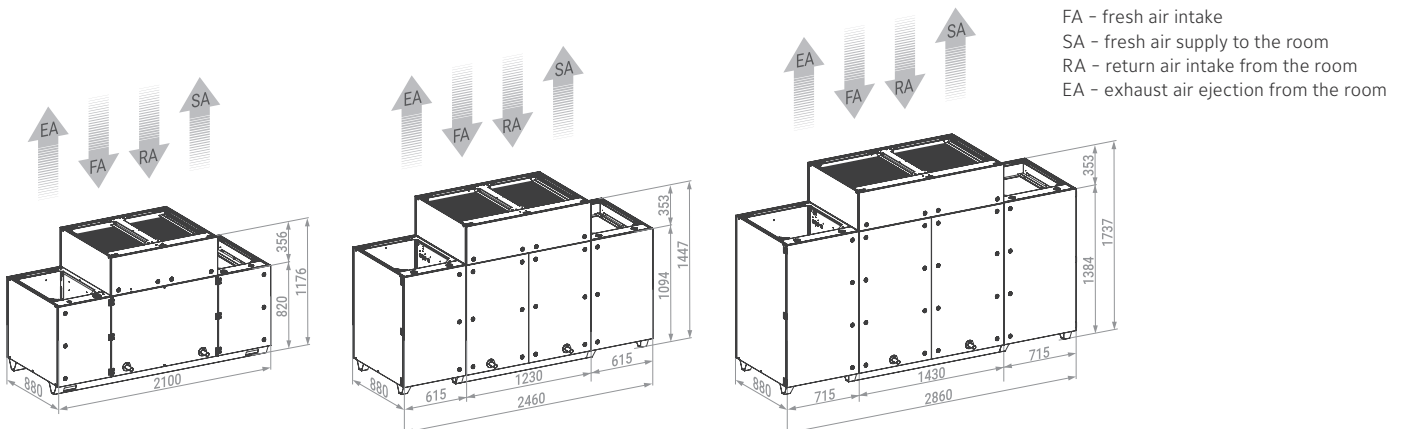

Manufacturer reserves the rights to change specifications without prior notice.

YBV-NG Compact TOP Floor-Mounted Units with Vertical Duct Connection

CASING

- Panels filled with mineral wool, enclosed with steel sheet on both sides.
- Casing parameters according to EN 1886: T2, TB3, L1, D1, F9.
- Fan and filter section panels fitted with hinges.



DIMENSIONS

- Unit width 88 cm - can be transported through the opening of 90 cm without disassembling the device.

CONTROLS

- Multifunctional controls, integrated with the unit - fully pre-configured and ready to run.

MINI-PLEAT OR BAG FILTERS

Air filters with extended high efficiency filtration surface.

- Supply - EU7
- Exhaust - EU5

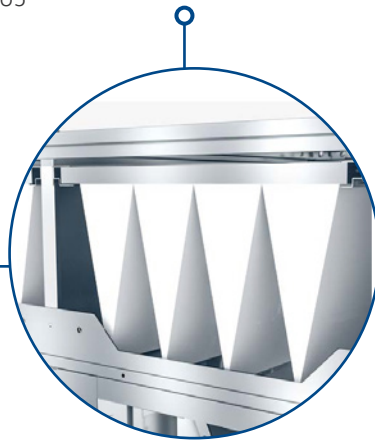
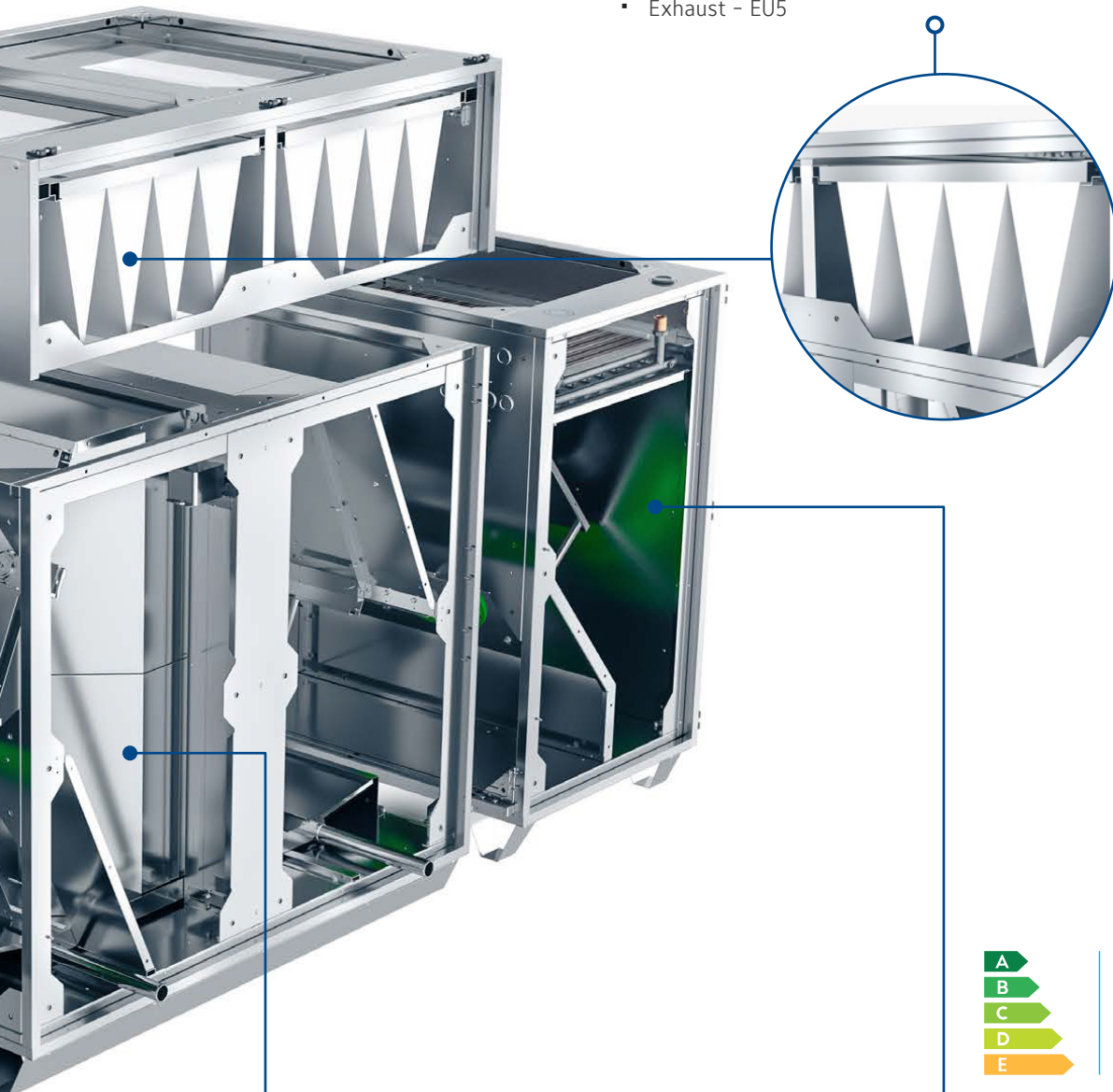

UP TO
93%
DRIVE EFFICIENCY

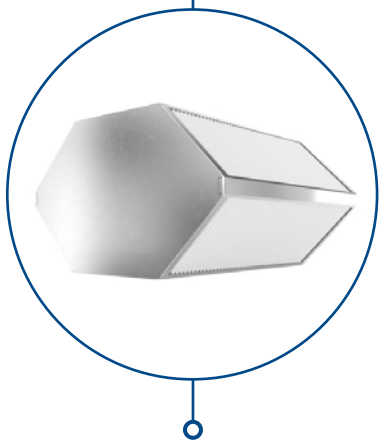

ENERGY RECOVERY

- Highly efficient counterflow hex recovery with by-pass.
- Recovery efficiency reaching 90%.

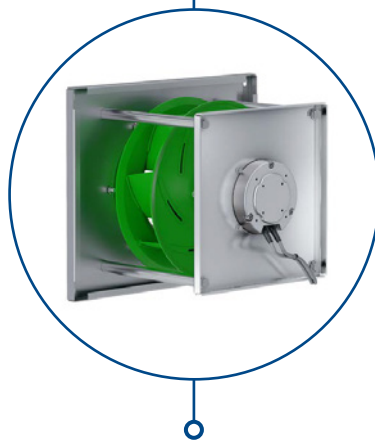

EC MOTORS

- Efficient, silent and low vibrations fan with electronically commutated motor in a IE4 class.

YKR

Compact Air Handling Units with Rotary Heat Exchanger

A complete range from 600 m³/h to 10,600 m³/h



Rotary Heat Recovery

YKR heat recovery ventilation units have high efficient rotary heat recovery exchangers. The exchanger transfers sensible heat and moisture between supply and exhaust air. Thus, it is also possible to transfer latent heat. With the optimization of heat exchanger, temperature and humidity efficiency is increased, pressure drop is decreased. Optionally, condensation rotor can be used for sensible heat transfer and sorption rotor can be used for humidity transfer.

Control System Plug&Play

YORK control unit is developed for controlling of heat recovery units' equipments, meeting the demands coming from the customers and is user friendly designed. The control unit is capable of controlling the standard equipments and optional accessories. YORK control unit can perform the basic functions. Besides, the control unit can be switched on/off via BMS, gets fault signals and controls all the functions via ModBus. Alternative controllers are listed in "Control System" part.

Exhaust and Supply Air Filters

To increase indoor air quality and to protect the equipments used in unit, F class filter (according to EN 779 standard) is used for supply air streams; M class filter is used for exhaust air streams. A choice of pre-filters (G3-G4) and final filters (M5-F9) are available optionally. Increased filter classification reduce the available static pressure of the unit.

Exhaust and Supply Air Fans

The fans in Compact Air Handling Units are equipped with innovative Electronically Commutated EC motor technology. EC motors have higher efficiency and simple speed control. Fan blades have high aerodynamic efficient backward curved design. EC motors reduce the energy consumption and increase the energy efficiency of the unit. With EC Fans, maintenance costs are reduced as the fans are directly connected to the motors; the belt and pulley problems are eliminated.

Casing & Insulation

The unit's casing is made up of double skinned high corrosion resistive 200 gr/m² galvanize coated steel. 50 mm thickness and 70kg/m³ density of Rockwool insulation between the walls is used for thermal and sound insulation. The case of unit is painted by electrostatic powdered paint. The unit is constructed in sections to ease transportation, mounting and commissioning. Every section has its own basis and transport slots.

Accessories

- Duct Type Electric Heaters
- Duct Type Heating / Cooling and DX Cooling Coil
- Duct Type Sound Attenuator

Compact Air Handling Units with Rotary Heat Exchanger

YKR-H Horizontal connection units

YKR-V Vertical connection units

Technical features

		YKR-H 100	YKR-H 200	YKR-H 300	YKR-H 400	YKR-H 500	YKR-H 700	YKR-H 900	YKR-H 1100
		YKR-V 100	YKR-V 200	YKR-V 300	YKR-V 400	YKR-V 500	YKR-V 700	YKR-V 900	YKR-V 1100
Declared typology		NRVU							
Type of drive installed or intended to be installed		variable speed drive							
Type of HRS (run around, other, none)		regenerative							
Thermal efficiency of heat recovery ¹	%	81.1	78.6	78.4	79.7	78.8	80.6	81.1	80.8
Nominal flow rate	m ³ /h	600	1300	1800	2500	3500	4000	5500	5800
Maximum flow rate	m ³ /h	1100	1700	2450	4050	5350	6800	8900	10600
Effective electric power input	W	376	706	934	1204	1692	2170	2554	2970
SFP _{int} ¹	W(m ³ /s)	1199.3	1179.3	1136.9	1023.2	1061.8	1130.7	935.3	1052.3
Face velocity at design flow rate	m/s	1.3	1.3	1.6	1.8	1.9	2	1.7	1.7
Nominal external pressure ($\Delta P_{s,ext}$) ¹	Pa	200	200	200	200	200	200	200	200
Internal pressure drop of ventilation components ($\Delta P_{s,int}$)	Pa	227	304	311	288	313	275	254	266
Internal pressure drop of non-ventilation components ($\Delta P_{s,add}$)	Pa	There is no "non-ventilation" components							
Static efficiency of fans used in accordance with Regulation (EU) No. 327/2001		38	52	55	56	59	49	54	51
Declared max. external leakage rate	%	Less than %3	3	2.9	0.9	Less than %3			
Declared max. internal leakage rate	%	NA							
Energy classification of the filters (Energy performance)	kWh	826	826	1331	1667	1835	2003	1499	1499
Description of visual filter warning for NRVUs intended for use with filters ²		www.solutionnavigator.com							
Sound power level (LWA)	dB(A)	57	52	46	49	61	61	63	65
Internet adress for pre-/dis-assembly instructions		www.solutionnavigator.com							

¹ Measured at balanced flow, EN 308.

² Including test pointing out the importance of regular filter changes for performance and energy efficiency of the unit.

Note: F7 class filter at supply side, M5 class filter at exhaust side are used according to EN 779.



Manufacturer reserves the rights to change specifications without prior notice.

YKC

Compact Air Handling Units with Counterflow Plate Heat Exchanger

A complete range from 1,500 m³/h to 7,360 m³/h



Heat Recovery Exchanger (Aluminum)

YKC heat recovery ventilation units have aluminum counterflow, high efficient plate heat recovery exchangers. Plate heat recovery exchangers have plates that are produced improved surface areas to provide high efficient and leakage free design. With the optimization of exchanger heat transfer is increased and pressure drop is decreased. Heat recovery exchanger has Eurovent certification.

Control System Plug&Play

YORK control unit is developed for controlling of heat recovery units' equipments, meeting the demands coming from the customers and is user friendly designed. The control is capable of controlling the standard equipments and optional accessories. YORK control unit can perform the basic functions. Besides, the control unit can be switched on/off via BMS, gets fault signals and controls all the functions via ModBus. Alternative controllers are listed in "Control System" part.

Exhaust and Supply Air Filters

To increase indoor air quality and to protect the equipments used in unit, F class filter (according to EN 779 standard) is used for supply air streams; M class filter is used for exhaust air streams. A choice of pre-filters (G3-G4) and final filters M5-F9) are available optionally. Increased filter classification reduce the available static pressure of the unit.

Casing & Insulation

The unit's casing is made up of double skinned high corrosion resistive 200 gr/m² galvanize coated steel. 50 mm thickness and 70kg/m³ density of Rockwool insulation between the walls is used for thermal and sound insulation. The case of unit is painted by electrostatic powdered paint. The unit is constructed in sections to ease transportation, mounting and commissioning.

Exhaust and Supply Air Fans

The fans in Compact Air Handling Units are equipped with innovative Electronically Commutated EC motor technology. EC motors have higher efficiency and simple speed control. Fan blades have high aerodynamic efficient backward curved design. EC motors reduce the energy consumption and increase the energy efficiency of the unit. With EC Fans, maintenance costs are reduced as the fans are directly connected to the motors; the belt and pulley problems are eliminated.

Accessories

- Duct Type Electric Heaters
- Duct Type Heating / Cooling and DX Cooling Coil

Compact Air Handling Units with Counterflow Plate Heat Exchanger

YKC-H Horizontal connection units

YKC-V Vertical connection units

Technical features

		YKC-H 200	YKC-H 300	YKC-H 400	YKC-H 500	YKC-H 700
		YKC-V 200	YKC-V 300	YKC-V 400	YKC-V 500	YKC-V 700
Declared typology		NRVU				
Type of drive installed or intended to be installed		variable speed drive				
Type of HRS (run around, other, none)		regenerative				
Thermal efficiency of heat recovery ¹	%	78	78	79	78	79
Nominal flow rate	m ³ /h	1500	2000	3000	3500	4500
Maximum flow rate	m ³ /h	2240	2690	4410	5350	7360
Effective electric power input	W	723	1023	1344	1570	2245
SFP _{int} ¹	W(m ³ /s)	960.5	1075.7	916.1	930.6	1891.4
Face velocity at design flow rate	m/s	1.5	1.6	1.6	1.9	2.3
Nominal external pressure ($\Delta P_{s,ext}$) ¹	Pa	200	200	200	200	200
Internal pressure drop of ventilation components ($\Delta P_{s,int}$)	Pa	238	271	253	262	197
Internal pressure drop of non-ventilation components ($\Delta P_{s,add}$)	Pa	There is no "non-ventilation" components				
Static efficiency of fans used in accordance with Regulation (EU) No. 327/2001		51.5	52	57.3	58.4	44.9
Declared max. external leakage rate	%	Less than %3				
Declared max. internal leakage rate	%	NA				
Energy classification of the filters (Energy performance) ²	kWh	NA				
Description of visual filter warning for NRVUs intended for use with filters ³		www.solutionnavigator.com				
Sound power level (LWA)	dB(A)	NA				
Internet adress for pre-/dis-assembly instructions		www.solutionnavigator.com				

¹ Measured at balanced flow, EN 308.

² Declared information about the calculated annual energy consumption.

³ Including test pointing out the importance of regular filter changes for performance and energy efficiency of the unit.

YKL

Compact Low Profile Air Handling Unit with Counterflow Plate Heat Exchanger

A complete range from 250 m³/h to 2,550 m³/h



Heat Recovery Exchanger (Aluminum)

YKL heat recovery ventilation units have aluminum counterflow, high efficient plate heat recovery exchangers. Plate heat recovery exchangers have plates that are produced improved surface areas to provide high efficient and leakage free design. With the optimization of exchanger heat transfer is increased and pressure drop is decreased. Heat recovery exchanger has Eurovent certification.

By-Pass

YKL units have by-pass ventilation as standard. During by-pass ventilation, no heat transfer occurs between exhaust and fresh air stream. In transition periods and at nights in summer, by-pass module helps to cool down (free-cooling) and heat up (free-heating) the building without any energy expense.

Control System Plug&Play

YORK control unit is developed for controlling of heat recovery units' equipments, meeting the demands coming from the customers and is user friendly designed. The control is capable of controlling the standard equipments and optional accessories. YORK control unit can perform the basic functions. Besides, the control unit can be switched on/off via BMS, gets fault signals and controls all the functions via ModBus. Alternative controllers are listed in "Control System" part.

Exhaust and Supply Air Filters

To increase indoor air quality and to protect the equipments used in unit, G class filters (according to EN 779 standard) are used for both exhaust and supply air streams. F class filters can be also used optionally in the unit. F class filters reduce the available static pressure of the unit for the nominal air flow rate.

Casing & Insulation

High corrosion resistive 200 gr/m² galvanize coated steel is used for the casing. Inside of outdoor air stream is insulated with 10 mm, outside of outdoor air stream is insulated with 5 mm; inside of indoor air stream is insulated with 10 mm non-flammable acoustics foam against sound and thermal conduction.

The YKL-D unit's casing is made up of double skinned high corrosion resistive 200 gr/m² galvanize coated steel. 30 mm thickness and 50kg/m³ density of Rockwool insulation between the walls is used for thermal and sound insulation. Non-flammable EPS modules are used for directing the air flow homogeneously. Density of EPS is 40 kg/m³.

Exhaust and Supply Air Fans

The fans in heat recovery units are equipped with innovative Electronically Commutated EC motor technology. EC motors have higher efficiency and simple speed control. Fan blades have high aerodynamic efficient backward curved design. Using the EC motors reduce the energy consumption and increase the energy efficiency of the unit. With EC Fans, maintenance costs are reduced as the fans are directly connected to the motors; the belt and pulley problems are eliminated.

Accessories

- Duct Type Electric Heaters
- Ventilation on Demand
- Sound Attenuator for Circular Ducts
- Final Filter (F Class - Optional)

Compact Low Profile Air Handling Unit with Counterflow Plate Heat Exchanger

YKL/YKL-D Low Profile Unit

Technical features

		YKL 250	YKL 500	YKL 800	YKL 1000	YKL 1500	YKL 2000
		YKL-D 250	YKL-D 500	YKL-D 800	YKL-D 1000	YKL-D 1500	YKL-D 2000
Declared typology		NRVU					
Type of drive installed or intended to be installed		variable speed drive					
Type of HRS (run around, other, none)		other					
Thermal efficiency of heat recovery ¹	%	85	82	82	82	80	83
Nominal flow rate	m ³ /h	250	500	750	1000	1500	1900
Maximum flow rate	m ³ /h	392	760	869	1288	2450	2550
Effective electric power input	W	58	144	242	277	495	678
SFP _{int} ¹	W(m ³ /s)	340	591	729	622	837	947
Face velocity at design flow rate	m/s	1	1.3	1.4	1.5	1.9	1.8
Nominal external pressure ($\Delta P_{s,ext}$) ¹	Pa	100	100	100	100	100	100
Internal pressure drop of ventilation components ($\Delta P_{s,int}$)	Pa	69	133	187	143	239	280
Internal pressure drop of non-ventilation components ($\Delta P_{s,add}$)	Pa	There is no "non-ventilation" components					
Static efficiency of fans used in accordance with Regulation (EU) No. 327/2001		39	45	50	49	57	59
Declared max. external leakage rate	%	1.4	0.1	0.2	0.3	0.8	0.6
Declared max. internal leakage rate	%	5.4	1.9	1.6	2.3	2.4	2.1
Energy classification of the filters (Energy performance)	kWh	NA					
Description of visual filter warning for NRVUs intended for use with filters ²		www.solutionnavigator.com					
Sound power level (LWA) ³	dB(A)	42	44	48	47	43	58
Internet adress for pre-/dis-assembly instructions		www.solutionnavigator.com					

¹ Measured at balanced flow, EN 308.

² Including test pointing out the importance of regular filter changes for performance and energy efficiency of the unit.

³ Sound power level values are valid for YKL units.

YKH

Residential Type Heat Recovery Unit with Plastic Counterflow Plate Heat Exchanger

A complete range from 65 m³/h to 620 m³/h



Heat Recovery Exchanger

YKH heat recovery ventilation units have plastic counterflow, high efficient plate heat recovery exchangers. Plate heat recovery exchangers have plates that are produced improved surface areas to provide high efficiency and leakage free design. With the optimisation of exchanger heat transfer is increased and pressure drop is decreased.

Control System Plug&Play

ENECON PLUS control unit is developed for controlling of heat recovery units' equipments, meeting the demands coming from the customers and is user friendly designed. ENECON is capable of controlling the standard equipments and optional accessories. ENECON PLUS Control unit can perform the basic functions without any control panel; it is more functional used with Standart Panel. Besides, the control unit can switch on/off via BMS and controls all the functions via ModBus. Alternatives different from Enecon Plus controller are listed in "Control System" part.

Exhaust and Supply Air Filters

To increase indoor air quality and to protect the equipments used in unit, G class filters (according to EN 779 standard) are used for both exhaust and supply air streams. F class filters can be also used optionally in the unit. F class filters reduce the available static pressure of the unit for the nominal air flow rate.

Casing

High corrosion resistive 200 gr/m² galvanize coated steel is used for the casing. The case of unit is painted by electrostatic powdered paint. Non-flammable EPS modules are used for directing the air flow homogeneously. Density of EPS is 40 kg/m³.

By-Pass

During by-pass ventilation, no heat transfer occurs between exhaust and fresh air stream. In transition periods and at nights in summer, by-pass module helps to cool down (free-cooling) and heat up (free-heating) the building without any energy expense.

Exhaust and Supply Air Fans

The fans in heat recovery units are equipped with innovative Electronically Commutated EC motor technology. EC motors have higher efficiency and simple speed control than AC motors and connect the AC mains. Fan blades have high aerodynamic efficient backward curved design. Using the EC motors reduce the energy consumption and increase the energy efficiency of the unit. With EC Fans it is also possible to reduce maintenance costs as the fans are direct drive; free of belt and pulley.

Accessories

- Duct Type Electric Heaters
- Ventilation on Demand
- Final Filter (F Class - Optional)

Residential Type Heat Recovery Unit with Plastic Counterflow Plate Heat Exchanger

YKH

Technical Specifications

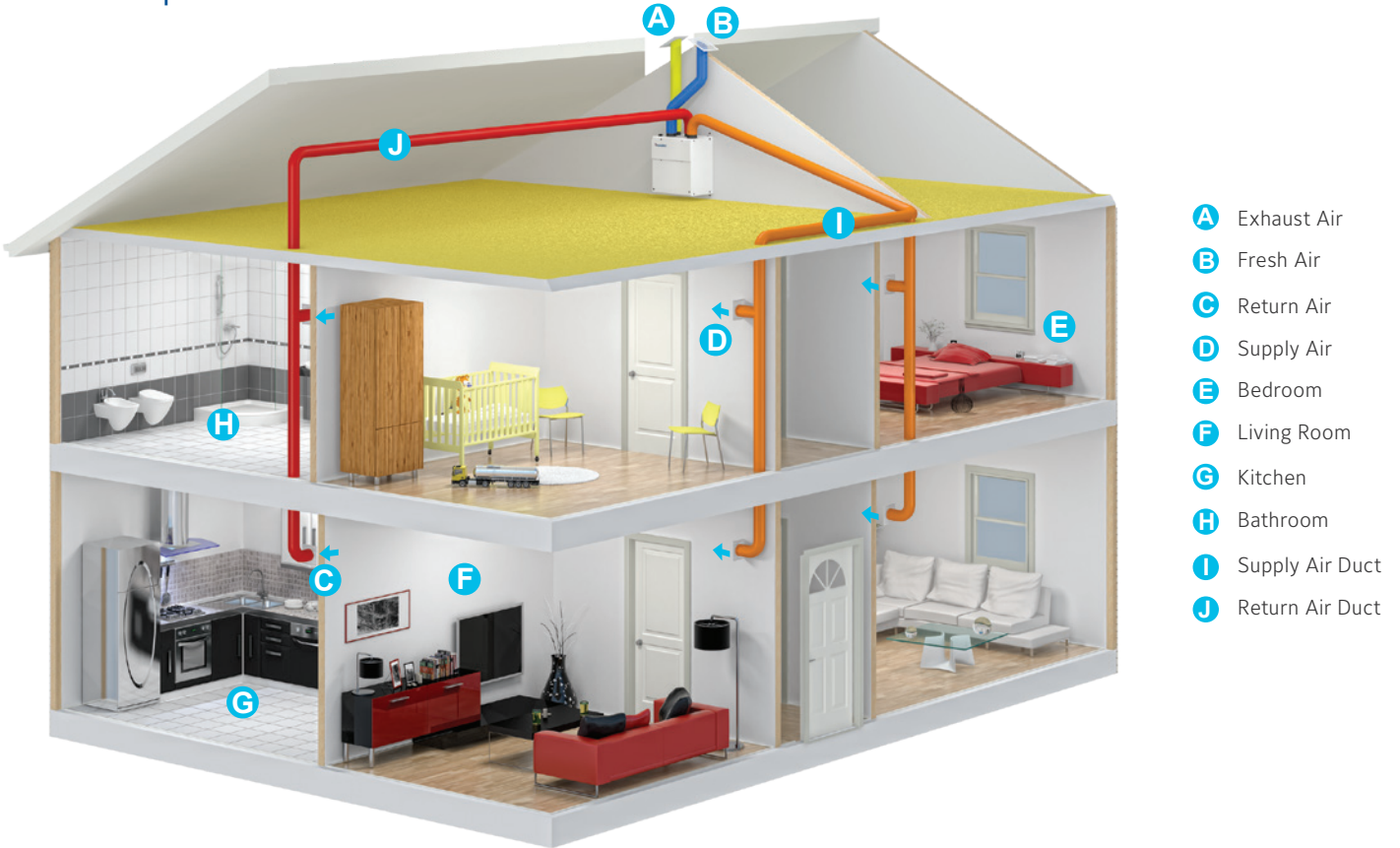

Fresh air is introduced to the ventilation system with fresh air duct. Fresh air is filtered with G class filter in the inlet of the unit. Fresh air is preconditioned through the counter-flow heat exchanger in the unit and then delivered to the demanded spaces in the house. Return air is exhausted from kitchen, bathroom, toilet and similar spaces where odours, steam etc. is created and delivered to the unit with return air ducts. To prevent fouling of the counter-flow heat exchanger G class filters are introduced to the unit. Return air is then exhausted outdoors after transferring its energy to fresh air.

YKH 300

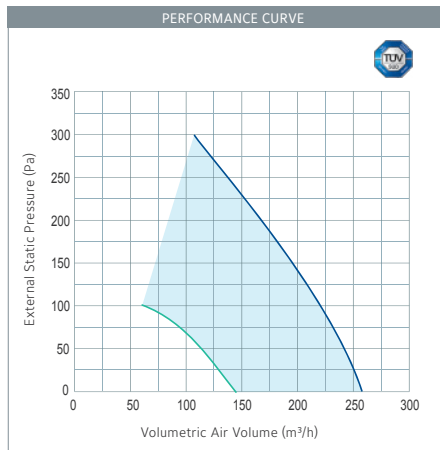

YKH 500

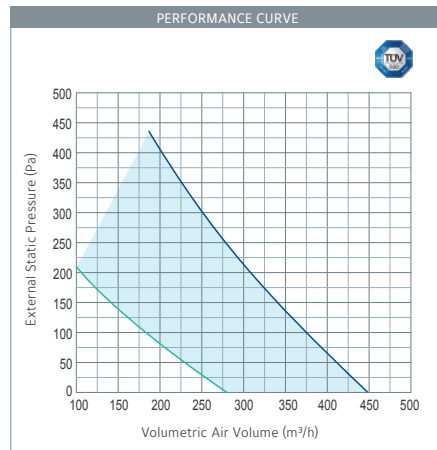

YKH 700

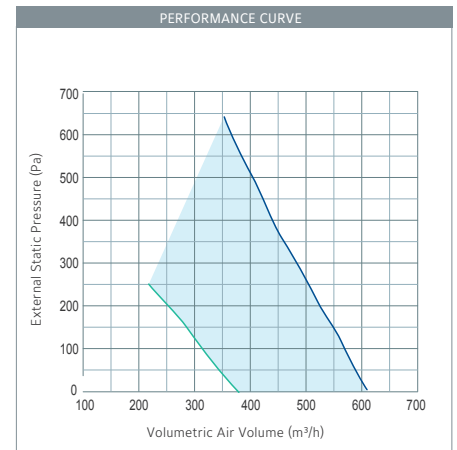

Manufacturer reserves the rights to change specifications without prior notice.

NEW

YKH2G

Residential Ventilation Heat Recovery Units with Counterflow Plate Heat Exchanger

A complete range from 150 m³/h to 600 m³/h



The YORK YKH2G units replace the exhaust air of indoor environments with filtered air coming from the outside thanks to a special high efficiency ePM1 55% - F7 class filter. The hexagonal counterflow recovery unit prevents any winter heat drops due to the introduction of fresh air, thereby recovering up to 92.5% of the extracted heat and conveying it to the clean air introduced in the occupied environment. Each unit is also equipped with an average efficiency filter (ePM10 50% - M5) installed on the inlet of the extraction section to prevent any dust from getting into the equipment.

All YORK YKH2G units comply with the 2018 efficiency limits imposed by Regulation 1253/14.

The Pro versions are equipped with an automatic centralised air flow control system operated by an integrated humidity sensor located in the extracted air duct. If the humidity of the indoor environment exceeds the reference parameters, to prevent the proliferation of mould and pathogenic bacteria, the fresh air flow is increased with the aim of restoring a healthy humidity level. The control also prevents from dropping below excessively low humidity levels, thus preventing excessively dry conditions inside the environments and, as a result, any health hazards. The units are NOT able, by themselves, to lower the level of internal humidity to a value below that of the outdoor. All the units can be controlled by means of a **supervisory system** in accordance with the following protocols:

- **Modbus**, with direct access to the dedicated RS 485 web gateway
- **Konnex**, with KNX interface board (optional).

As well as the type of installation, the range can also be classified according to the type of control:

- **Pro unit** with automatic centralised control via humidity probe:
 - YKH2G-SP (vertical)
 - YKH2G-SHP (horizontal/vertical)
- **Standard unit** with time programming control:
 - YKH2G-S (vertical)

YKH2G-SP and YKH2G-S units are designed for vertical wall installation or, with the addition of feet, floor installation. Instead, YKH2G-SHP units are ideal for both horizontal ceiling installation and vertical wall installation. The width of the YKH2G-SHP and YKH2G-S units is such as to ensure easy insertion into modular kitchen components, since the width is less than 600 mm.

Technical features

Vertical version with T-EP built-in/wall control

Pro version

Version	Model	Max flow at 100 Pa (m³/h)	Energy class	Width (mm)	Humidity sensor	Automatic air flow control
Pro	YKH2G-SP-180	180	A+	600	✓	✓
	YKH2G-SP-280	280	A+	600	✓	✓
	YKH2G-SP-370	370	A+	660	✓	✓
	YKH2G-SP-460	460	A	660	✓	✓
	YKH2G-SP-600	600	A	660	✓	✓
Pro with LH electric heater	YKH2G-SPEL-180	180	A+	600	✓	✓
	YKH2G-SPEL-280	280	A+	600	✓	✓
	YKH2G-SPEL-370	370	A+	660	✓	✓
	YKH2G-SPEL-460	460	A	660	✓	✓
	YKH2G-SPEL-600	600	A	660	✓	✓
Pro with RH electric heater	YKH2G-SPER-180	180	A+	600	✓	✓
	YKH2G-SPER-280	280	A+	600	✓	✓
	YKH2G-SPER-370	370	A+	660	✓	✓
	YKH2G-SPER-460	460	A	660	✓	✓
	YKH2G-SPER-600	600	A	660	✓	✓

Version	Model	Max flow at 100 Pa (m³/h)	Energy class	Width (mm)	Humidity sensor	Automatic air flow control
Standard	YKH2G-S-170	170	A	550	(*)	(**)
	YKH2G-S-270	270	A	550	(*)	(**)
	YKH2G-S-360	360	A	550	(*)	(**)
	YKH2G-S-460	460	A	660	(*)	(**)
	YKH2G-S-600	600	A	660	(*)	(**)
Standard with LH electric heater	YKH2G-SEL-170	170	A	550	(*)	(**)
	YKH2G-SEL-270	270	A	550	(*)	(**)
	YKH2G-SEL-360	360	A	550	(*)	(**)
	YKH2G-SEL-460	460	A	660	(*)	(**)
	YKH2G-SEL-600	600	A	660	(*)	(**)
Standard with RH electric heater	YKH2G-SER-170	170	A	550	(*)	(**)
	YKH2G-SER-270	270	A	550	(*)	(**)
	YKH2G-SER-360	360	A	550	(*)	(**)
	YKH2G-SER-460	460	A	660	(*)	(**)
	YKH2G-SER-600	600	A	660	(*)	(**)

Horizontal and vertical version

Version	Model	Max flow at 100 Pa (m³/h)	Energy class	Height (mm)	Humidity sensor	Automatic air flow control	T-EP
Pro	YKH2G-SHP-150	150	A	191	✓	✓	(***)
	YKH2G-SHP-170	170	A+	330	✓	ND	✓
	YKH2G-SHPL-270 ⁽¹⁾	270	A	278	✓ ⁽³⁾	✓	✓
	YKH2G-SHPR-270 ⁽²⁾	270	A	278	✓ ⁽³⁾	✓	✓
Pro left range with electric heater	YKH2G-SHPEL-170	170	A+	330	✓	ND	✓
	YKH2G-SHPEL-270	270	A	278	✓ ⁽³⁾	✓	✓
Pro right range with electric heater	YKH2G-SHPER-170	170	A+	330	✓ ⁽³⁾	ND	✓
	YKH2G-SHPER-270	270	A	278	✓ ⁽³⁾	✓	✓

(1) left configuration (2) right configuration (3) double sensor

(*) Humidity Sensor available as accessory

(**) Pressure transducer for the automatic control of air flow rates, available as accessory

(***) T-EP wall control available as accessory



Manufacturer reserves the rights to change specifications without prior notice.

YEPR Heat Recovery Units

A complete range from 300 m³/h up to 2,600 m³/h



Introduction

The high-efficiency heat recovery units of the **YEPR** series have been designed to ensure energy savings in ventilation systems of public and private premises such as bars, restaurants, offices, shops, etc., making it possible to recover heat from the exhaust air and transferring it to the air released into the room.

The heat exchange between the exhaust air and the intake air takes place through a static heat exchanger with countercurrent flow, sized to obtain a heat recovery up to 94%.

The **YEPR** series includes 4 sizes suitable for horizontal installation and covers a range of flow rates from 300 to 2600 m³/h. The units are available both in the version for installation on ceilings and floors.

Construction features

The **YEPR** are supplied in 2 versions:

- for ceiling installation

(YEPR 1-C, YEPR 2-C, YEPR 3-C, YEPR 4-C)

- for floor installation

(YEPR 1-F, YEPR 2-F, YEPR 3-F, YEPR 4-F)

and they are equipped with centrifugal fans, featuring backward-inclined blades, and a continuous modulation electronic motor which ensure variable flow control, so as to reduce power consumption to the minimum necessary.

The YEPR units are ERP 2018 and therefore comply with the regulatory requirements of the European Ecodesign Directive (EU Regulation 1253/14). The checks concern both the energy performance relating to heat recovery and the intrinsic energy consumption parameter SFP_{int} in the nominal conditions declared by the manufacturer.

YEPR range

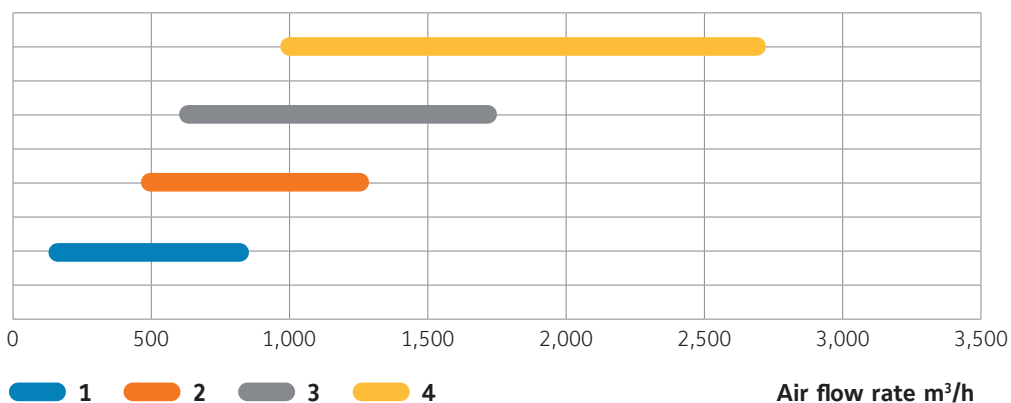

YEPR Heat Recovery Units

YEPR 1 to 4

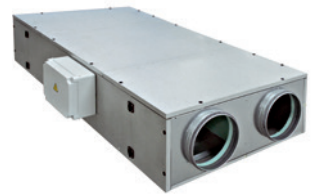

Technical features

Model		YEPR 1	YEPR 2	YEPR 3	YEPR 4
Maximum supply and return air flow rate	m³/h	720	1150	1700	2600
	m³/h	0.20	0.32	0.47	0.72
Supply and return rated available static pressure	Pa	170	220	250	250
Minimum supply and return air flow rate	m³/h	270	300	600	690
Thermal efficiency EU regulation 1253/14 (1)	%	80	80	80	85
Total thermal output recovered (1)	kW	3.9	6.2	9.1	14.8
Maximum recovery efficiency (2)	%	90	90	90	94
Total thermal output recovered (2)	kW	6.5	10.5	15.4	24.5
Total number of fans	-	2	2	2	2
Rated absorbed electrical power (3)	W	330	770	1060	1460
Maximum total absorbed current (3)	A	2.8	3.4	4.7	6.5
Unit power supply (3)	V-Ph	230-1 + N / 50Hz	230-1 + N / 50Hz	230-1 + N / 50Hz	230-1 + N / 50Hz
Protection rating with machine installed	-	IP20	IP20	IP20	IP20
Unit weight	kg	90	140	170	320

- 1) Air conditions: EAT = 5°C and t_i = 25°C, no condensate
 2) Air conditions: EAT = -10°C and t_i = 20°C, RH_i 50% RH
 3) Basic version

Overall dimensions of the packaged unit

Model		YEPR 1	YEPR 2	YEPR 3	YEPR 4
Dimensions	D mm	469	510	595	735
	E mm	1845	1845	2245	2345
	F mm	1030	1030	1430	1880
Weight	kg	119	165	198	370

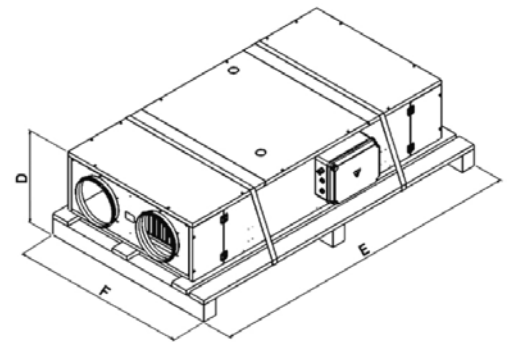

Thermal performances - Internal conditions: t_i = 20°C - RH_i = 50%

Model	EAT: 10°C				EAT: 5°C				EAT: 0°C				EAT: -5°C				EAT: -10°C			
	Q _v m³/h	P _h kW	ε _t %	m _w kg/h	P _h kW	ε _t %	m _w kg/h	P _h kW	ε _t %	m _w kg/h	P _h kW	ε _t %	m _w kg/h	P _h kW	ε _t %	m _w kg/h				
YEPR 1	100	0.30	90.4	0.00	0.46	90.5	0.15	0.62	91.7	0.26	0.79	94.3	0.36	0.97	96.5	0.44				
	150	0.44	88.2	0.00	0.67	88.3	0.21	0.90	89.8	0.38	1.17	92.7	0.53	1.44	95.4	0.65				
	300	0.85	84.6	0.00	1.28	84.7	0.42	1.74	86.4	0.72	2.26	90.0	1.03	2.81	93.2	1.25				
	450	1.25	82.6	0.00	1.87	82.7	0.62	2.55	84.5	1.09	3.34	88.4	1.52	4.16	91.9	1.85				
	600	1.63	81.2	0.00	2.45	81.3	0.81	3.35	83.2	1.43	4.39	87.3	2.01	5.49	90.9	2.47				
YEPR 2	750	2.01	80.1	0.00	3.03	80.2	0.96	4.13	82.2	1.71	5.43	86.4	2.43	6.80	90.1	3.01				
	200	0.60	89.4	0.00	0.90	89.5	0.29	1.22	90.8	0.51	1.57	93.5	0.70	1.93	96.0	0.86				
	250	0.74	88.2	0.00	1.11	88.3	0.36	1.50	89.7	0.63	1.94	92.7	0.88	2.40	95.3	1.08				
	500	1.42	84.6	0.00	2.13	84.7	0.69	2.90	86.4	1.20	3.77	90.0	1.72	4.69	93.2	2.08				
	750	2.08	82.5	0.00	3.12	82.6	1.04	4.25	84.5	1.81	5.56	88.4	2.52	6.93	91.8	3.09				
YEPR 3	1000	2.72	81.1	0.00	4.08	81.2	1.35	5.57	83.1	2.38	7.31	87.2	3.35	9.14	90.8	4.12				
	1250	3.35	80.0	0.00	5.04	80.1	1.68	6.88	82.1	2.85	9.04	86.3	4.05	11.32	90.0	5.00				
	300	0.89	88.4	0.00	1.34	88.5	0.43	1.81	89.9	0.76	2.34	92.9	1.06	2.88	95.5	1.31				
	400	1.17	86.9	0.00	1.75	87.0	0.56	2.38	88.5	1.00	3.08	91.8	1.37	3.81	94.6	1.69				
	800	2.24	83.4	0.00	3.36	83.5	1.10	4.57	85.2	1.91	5.97	89.0	2.66	7.44	92.4	3.36				
YEPR 4	1200	3.27	81.4	0.00	4.92	81.5	1.64	6.71	83.4	2.88	8.79	87.4	3.90	10.99	91.0	4.97				
	1650	4.42	79.8	0.00	6.63	79.9	2.20	9.06	81.9	3.88	11.91	86.1	5.31	14.92	89.9	6.57				
	2000	5.29	78.9	0.00	7.95	79.0	2.53	10.87	81.0	4.54	14.31	85.4	6.49	17.95	89.2	8.05				
	400	1.28	95.3	0.00	1.92	95.4	0.63	2.58	96.1	1.10	3.27	97.5	1.50	3.97	98.7	1.75				
	550	1.72	93.5	0.00	2.59	93.6	0.84	3.49	94.5	1.49	4.44	96.4	1.98	5.42	98.0	2.43				
YEPR 4	1100	3.31	89.7	0.00	4.97	89.8	1.61	6.72	91.1	2.82	8.65	93.8	3.89	10.64	96.1	4.74				
	1700	4.98	87.4	0.00	7.48	87.5	2.45	10.14	89.0	4.34	13.13	92.1	5.87	16.23	94.9	7.25				
	2300	6.62	85.8	0.00	9.94	85.9	3.22	13.50	87.5	5.77	17.53	90.9	7.90	21.74	93.9	9.83				
	2900	8.23	84.6	0.00	12.36	84.7	4.02	16.81	86.4	6.97	21.88	90.0	9.99	27.19	93.2	12.09				

- t_i = Internal air temperature
 RH_i = Internal relative humidity
 EAT = External air temperature
 Q_v = Intake air flow rate
 Q_r = Return air flow rate
 P_h = Thermal recovery on the intake flow

- ε_t = Recovery efficiency with balanced flow rates
 m_w = Condensate production
 b = Unbalance percentage
 ε_t* = Recovery efficiency with unbalanced flow rates
 F_t = Correction coefficient according to EAT variation
 F_Q = Correction coefficient according to Q_v variation

$$\epsilon_t = \frac{2980 P_h}{Q_v (t_i - TAE)}$$

$$b = Q_r / Q_v$$

$$\epsilon_t^* = \epsilon_t b F_t F_Q$$



Manufacturer reserves the rights to change specifications without prior notice.



Rooftop Equipment

YORK offers a complete range of rooftop equipments within **18 kW to 219 kW capacities**, to cover all customer needs, maintaining the highest efficiency levels and operative performances.

YORK Rooftop Cooling Only Units

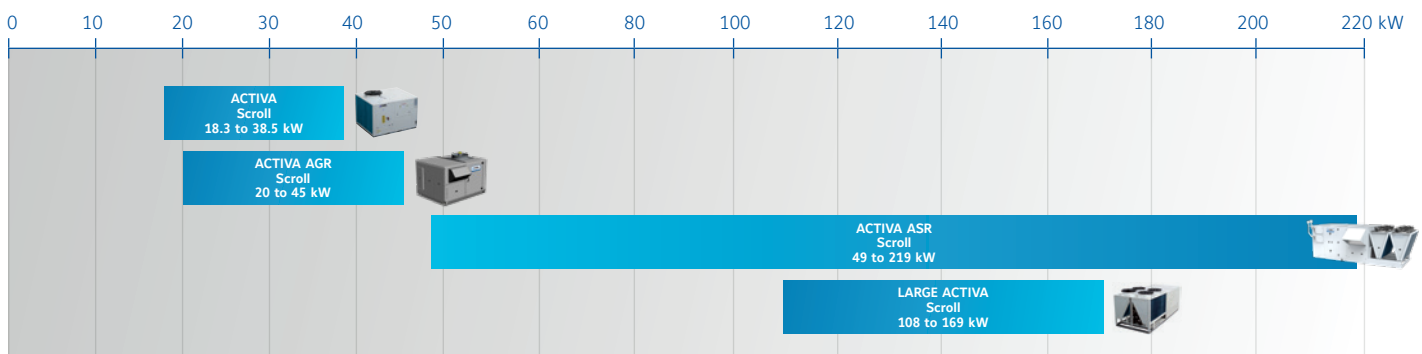

YORK Rooftop Heat Pump Units

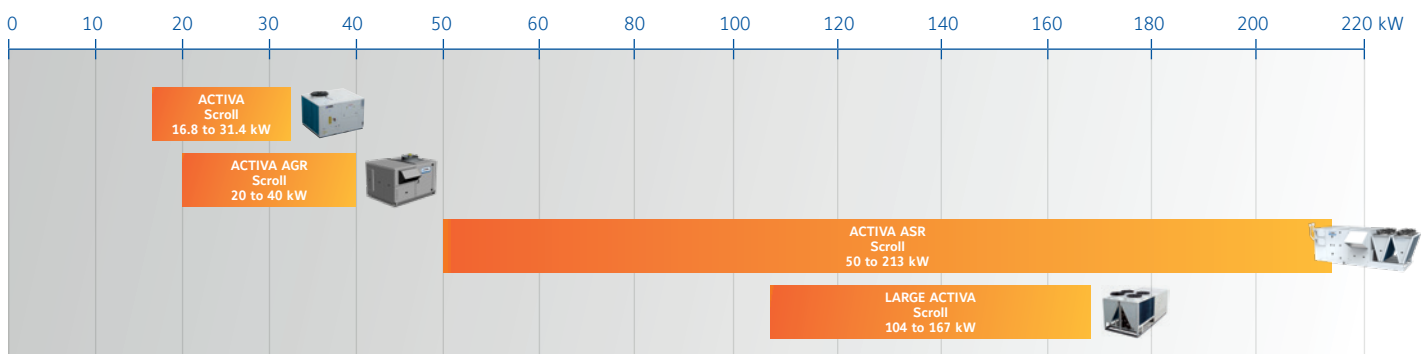

Three different Energy Recovery systems with the new ASR Rooftop range

RECO system recovery Economiser with 3 dampers

The factory-mounted economiser with 3 dampers, is equipped with an EC plug fan return fan as a standard. The economiser increases the partial load operation of the compressors and improves the seasonal efficiency thanks to a proportional-action control function.

The economiser with 3 combined dampers, with proportional modulation of the outdoor-recycled-extracted air allows an extraction up to 100% of the total air flow (in equivalent quantity to the intake of outdoor air).

It provides real energy savings by regulating the air renewal.

TRECO system recovery Thermodynamic Energy Recovery

This option is available only on the ASR rooftop equipped with 3 dampers (not compatible with the FRECO system).

This thermodynamic system for recovering energy between the exhaust air and fresh air is delivered entirely mounted and factory tested.

It is composed of an independent refrigeration circuit and a dedicated control.

FRECO system recovery From the food refrigeration system

The ASR rooftop provided with a FRECO system uses the heat generated by the condensers of the refrigeration systems of a supermarket as a free source of heat.

The refrigerated cabinets of the store extract heat on a water loop. A water/water chiller transfers that heat on a secondary water loop.

In standard, that heat is removed by a dry-cooler.

The FRECO coil enables to valorize that heat for thermal comfort application and it will moderate the use of the ASR rooftop thermodynamic circuit.

ACTIVA Rooftop

ARC-ARG-ARH-ARD

A complete range from 18.3 kW up to 38.5 kW



YKN2open

Features

- High efficiency EER and COP
- Ecodesign ErP 2021 compliant
- Low noise level
- EC supply fan
- All configurations: Cooling only, Cooling + gas, Heating, Heating + Gas
- BMS connection as standard (N2Open protocol)
- Compact design
- Energy recovery (enthalpy wheel)
- External HP & LP access
- Filters G4, F6 & F7 available

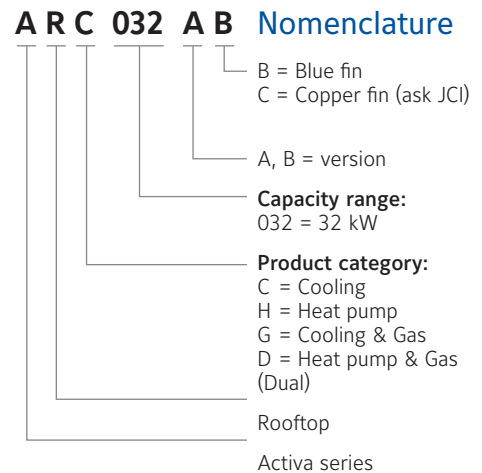

ACTIVA Rooftop

ARC-ARG-ARH-ARD 017 to 040 AB/BB



Technical features

Cooling only models		ARC 017 AB	ARC 022 AB	ARC 032 AB	ARC 040 AB	
Net cooling capacities	kW	18.3	22.3	31	38.5	
Power input	kW	5.3	7.0	8.67	14.1	
SEER		3.82	3.85	4.06	3.93	
ηs,c		149.6	151.1	159.4	154	
Working range (full load / partial load)	°C	7°C ~ 46°C / -10°C ~ 52°C				
Heat pump models		ARH 017 BB	ARH 022 BB	ARH 032 AB	-	
Net cooling capacities	kW	18.3	22.3	31	-	
Power input in cooling	kW	5.3	7.0	8.67	-	
Heating capacities (1)	kW	16.8	22.1	31.4	-	
Power input in heating	kW	4.7	5.9	8.72	-	
SCOP		3.23	3.24	3.27	-	
ηs,h		126	127	128	-	
Working range (full load / partial load)	°C	-10°C ~ 46°C / -10°C ~ 52°C				
Cooling only + Gas heating models		ARG 017 AB	ARG 022 AB	ARG 032 AB	ARG 040 AB	
Net cooling capacities	kW	18.3	22.3	31	38.5	
Cooling power input	kW	5.3	7.0	8.67	14.1	
Standard Heating capacities (1) NET	kW	23	23	41	41	
Natural gas 2ND-H, G20	m³/h	2.5	2.5	4.5	4.5	
Working range (full load / partial load)	°C	-15°C ~ 46°C / -15°C ~ 52°C				
Heat pump + Gas heating models		ARD 017 BB	ARD 022 BB	ARD 032 AB	-	
Net cooling capacities	kW	18.3	22.3	31	-	
Power input in cooling	kW	5.3	7.0	8.67	-	
Heating capacities (1)	kW	16.8	22.1	31.4	-	
Power input in heating	kW	4.7	5.9	8.72	-	
Standard Heating capacities (1) NET	kW	23	23	41	-	
Natural gas 2ND-H, G20	m³/h	2.5	2.5	4.5	-	
Working range (full load / partial load)	°C	-15°C ~ 46°C / -15°C ~ 52°C				
Common characteristics						
Power supply		400V/3 + N/ 50Hz				
Main switch	A	20	25	40	50	
Main cable	Nbr. x mm²	5 x 4	5 x 6	5 x 10	5 x 16	
Cable to thermostat	Nbr. x mm²	10 x 0.22				
Number of circuits / Compressor type		1 / 1 x Scroll		1 (Tandem) / 2 x Scroll		
Evaporator fan at nominal airflow	Airflow	m³/h	3400	4300	5700	7400
	ASP	Pa	600	600	600	600
Nett dimensions	Height	mm	1 420	1 420	1 420	1 420
	Length	mm	1 866	1 866	2 135	2 135
	Depth	mm	1 540	1 540	1 850	1 850
Nett weight ARC / ARG		kg	420 / 462	440 / 482	581 / 642	585 / 646
Nett weight ARH / ARD		kg	425 / 467	445 / 487	587 / 648	-

All the data are at EUROVENT conditions with 400V/3+N/50Hz.

Cooling : Entering indoor coil temp. 27°C / 19°C WB and outdoor temperature 35°C - Heating : Entering indoor coil temp. 20°C and outdoor temperature 7°C / 6°C WB

(1) Add indoor fan motor consumption to know total heating capacity.

Codes

Cooling only models	ARC 017 AB	ARC 022 AB	ARC 032 AB	ARC 040 AB
	S661752110	S661752120	S661752130	S661752150
Heat pump models	ARH 017 BB	ARH 022 BB	ARH 032 AB	-
	S661752513	S661752127	S661752133	-
Cooling only + Gas heating models	ARG 017 AB	ARG 022 AB	ARG 032 AB	ARG 040 AB
	S661752111	S661752121	S661752131	S661752151
Heat pump + Gas heating models	ARD 017 BB	ARD 022 BB	ARD 032 AB	-
	S661752118	S661752128	S661752132	-
Thermostat				
to be ordered separately			DPC-1	



Manufacturer reserves the rights to change specifications without prior notice.

Activa rooftop details and features

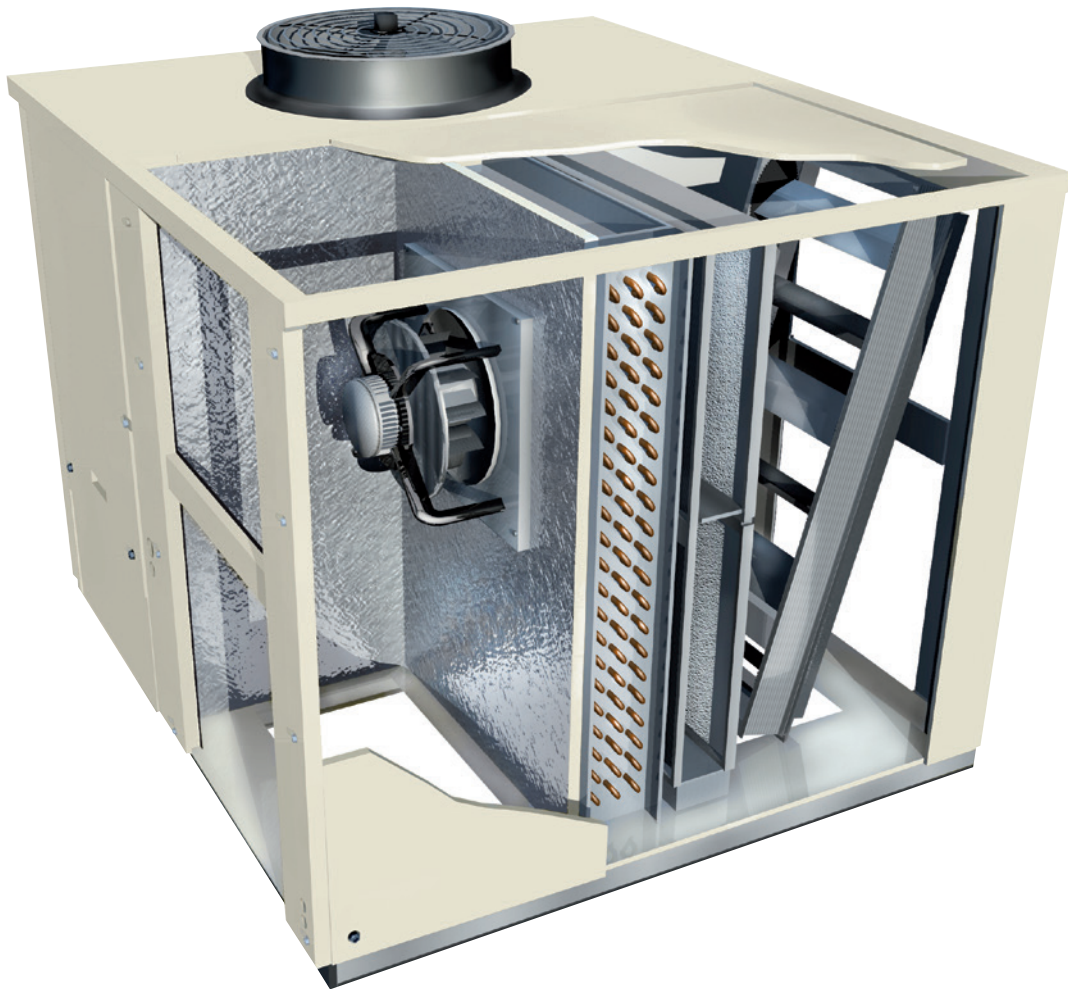

High Efficiency

High efficiency compressor and fans managed by an smart control allows the unit to achieve and maintain the level of comfort required in the most efficient way, reducing therefore the energy bill.

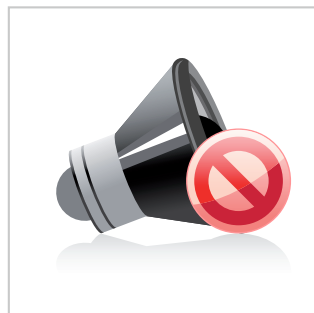

Low Noise

Ultra quiet fans and optimized airflow reduces the noise level increasing the comfort. Compressors are mounted on shock absorbers and anti-vibration springs are available to avoid vibration transmissions into de building.



Easy Installation and Maintenance

The high level of usability of the control, the internal solutions adopted (like direct driven fans with variable speed) and the easy access to components simplify and reduce the need of external interventions. Full information on commissioning and maintenance plan are provided to help to ensure unit keeps running always in optimal conditions.



Compact Design

The refrigerant circuit layout has been redesigned and high efficiency exchangers been used to reduce the footprint and improve the transport and handling. Transition roofcurbs are available to fit in existing installations.

Accessories and options

	Code	Cooling only				Heat pump			Cooling + gas heating				Heat pump + gas heating		
		017	022	032	040	017	022	032	017	022	032	040	017	022	032
Thermostat DPC-1	S603786044	A	A	A	A	A	A	A	A	A	A	A	A	A	A
YNK2Open Gateway BACnet / IP - JCI Metasys N2	S606791244	A	A	A	A	A	A	A	A	A	A	A	A	A	A
YNK2Open Gateway Modbus TCP / IP - JCI Metasys N2	S606791245	A	A	A	A	A	A	A	A	A	A	A	A	A	A
Dry bulb triple input economizer or motorized air damper with rain hood	S611752301	O	O			O	O		O	O			O	O	
	S611752311			O	O			O			O	O			O
Enthalpy probes	S613990081	O	O	O	O	O	O	O	O	O	O	O	O	O	O
Indoor air quality sensor	S606819964	O/A	O/A	O/A	O/A	O/A	O/A	O/A	O/A	O/A	O/A	O/A	O/A	O/A	O/A
Power Exhaust	S611752302	A	A			A	A		A	A			A	A	
	S611752312			A	A			A			A	A			A
Barometric relief damper and rain hood	S611752472	A	A			A	A		A	A			A	A	
	S611752473			A	A			A			A	A			A
Fresh air damper and rain hood (2)	S611752303	A	A			A	A		A	A			A	A	
	S611752313			A	A			A			A	A			A
Low ambient kit	S611752381	O	O	O	O	O	O	O	O	O	O	O	O	O	O
Roofcurb adapter (3)	S611752886	A	A			A	A		A	A			A	A	
	S611752887			A	A			A			A	A			A
Fixed roof curb	S611752881	A	A			A	A		A	A			A	A	
	S611752882			A	A			A			A	A			A
Adjustable roof curb	S611752883	A	A			A	A		A	A			A	A	
	S611752884			A	A			A			A	A			A
Dirty filter switch	S613990085	O	O	O	O	O	O	O	O	O	O	O	O	O	O
Smoke detector	S613995382	O	O	O	O	O	O	O	O	O	O	O	O	O	O
Fire detection thermostat	S613903003	O	O	O	O	O	O	O	O	O	O	O	O	O	O
Hot water coil	S611752351	O	O			O	O								
	S611752352			O	O			O							
Electric heaters	16 kW	S611752516	O	O			O	O							
	16 kW	S611752616			O	O			O						
	25 kW	S611752525	O	O			O	O							
	25 kW	S611752625			O	O			O						
	37 kW	S611752537			O	O			O						
Propane conversion Kit	S611752780								A	A	A	A	A	A	A
Filter kit F6	S611752401	O	O			O	O		O	O			O	O	
	S611752402			O	O			O			O	O			O
Filter kit F7	S611752411	O	O			O	O		O	O			O	O	
	S611752412			O	O			O			O	O			O
Grill condenser coil protection	S611752451	O	O			O	O		O	O			O	O	
	S611752452			O	O			O			O	O			O
Antivibration mounting kit	S611752461	A	A	A	A	A	A	A	A	A	A	A	A	A	A
Energy recovery	S611752501	A	A			A	A		A	A			A	A	
	S611752511			A	A			A			A	A			A
Filter kit F6 for energy recovery	S611755506	O	O			O	O		O	O			O	O	
	S611755516			O	O			O			O	O			O
Filter kit F7 for energy recovery	S611752507	O	O			O	O		O	O			O	O	
	S611752517			O	O			O			O	O			O
Alarm relay board	S606791243	O/A	O/A	O/A	O/A	O/A	O/A	O/A	O/A	O/A	O/A	O/A	O/A	O/A	O/A
Copper-copper coil	Contact us	O	O	O	O	O	O	O	O	O	O	O	O	O	O

O=Option (factory fitted). A=Accessory (supplied loose). O/A=If you want this item factory fitted, precise it in the order form.

(1) Energy recovery accessory includes: economizer, rain hood, indoor air quality sensor and G4 filters.

(2) Fresh air damper can not be installed if economizer or motorized damper is fitted.

(3) Transition roofcurbs to fit in D_IC/D_IG/B_IG existing installations (090-150 kbtu/h).

ACTIVA AGR Rooftop

Cooling capacity from 20 kW up to 45kW
 Heating capacity from 20 kW up to 40 kW

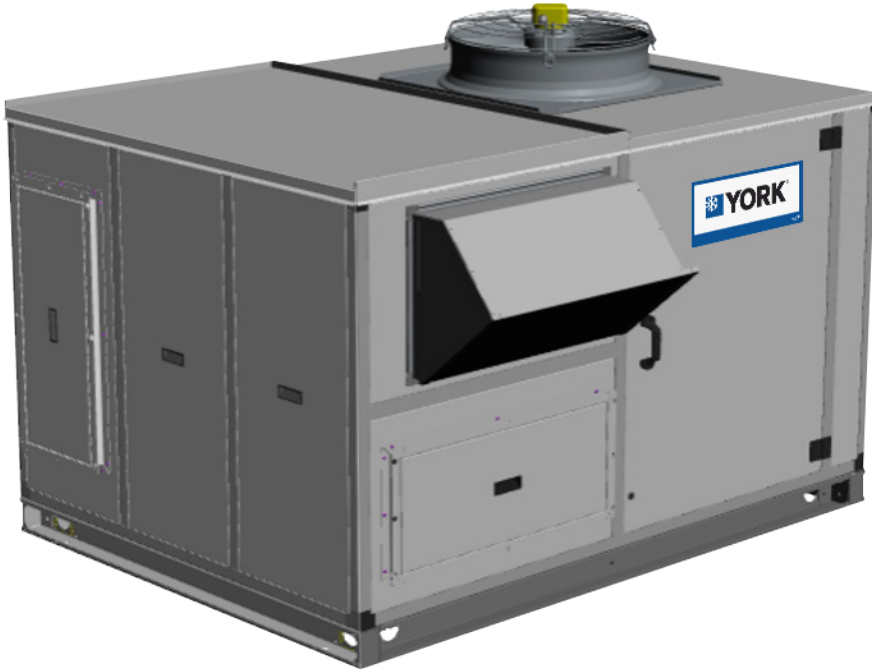

This new generation of high efficiency rooftop units have been thought and designed to reach the Ecodesign 2021 threshold. It reaches the energy class A.

The ACTIVA AGR units are available in cooling-only or reversible (H) versions and with a wide range of options.

Features

- High efficiency EER and COP
- Ecodesign ErP 2021 compliant
- Cooling only and Reversible Heat Pump versions
- Inverter Scroll compressor
- Many air inlet/outlet configurations
- Single panel skin as standard
- EC Inverter Plug Fan
- Advanced logic control
- Pre-coated fins treatment

Options and Accessories

- ECA plug fans
- Gas burner
- Electrical heater
- Heat recovery external module
- Gas burner
- F7 and F8 plate filters
- Freecooling
- IAQ (indoor air quality control)
- Modbus, BACnet and SNMP protocols
- High and low pressure gauges

All recirculation: Basic unit

- No dampers.
- Recommended for rooms with an independent air renewal system.

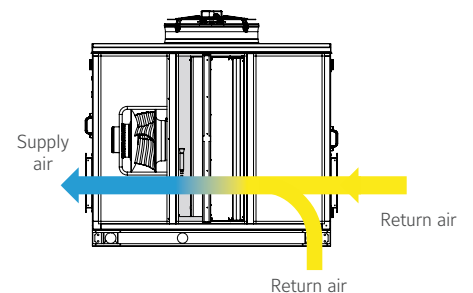

ACTIVA AGR Rooftop

AGR 019 to 040



Technical features

Cooling only models			AGR 019	AGR 024	AGR 032	AGR 040
Cooling capacities	kW		19.1	24.0	32.3	39.7
Power input	kW		5.9	7.9	10.3	14.4
SEER			5.15	4.37	3.98	3.82
$\eta_{s,c}$			203	172	156	150
Heat pump models			AGR 019	AGR 024	AGR 032	AGR 040
Cooling capacities	kW		19.1	24.0	32.3	39.7
Power input in cooling	kW		5.9	7.9	10.3	14.4
SEER			5.15	4.37	3.98	3.82
$\eta_{s,c}$			203	172	156	150
Heating capacities	kW		19.8	25.3	34.3	45.3
Power input in heating	kW		5.8	6.8	9.7	14.5
SCOP			3.72	3.57	3.46	3.52
$\eta_{s,h}$			146	140	135	138
Common characteristics						
Power supply	400V/3 + N/ 50Hz					
Air flow	m ³ /h		3750	5000	6400	7800
Available Static Pressure	Pa		100	120	120	150
Sound power level	dB(A)		88	88	89	91
Sound pressure level	dB(A)		71	71	72	74
Fans	#		1			
Fan type	EC Inverter Plug-Fan					
Number of circuits / Compressor type	1 / 1 x Scroll Inverter					
Refrigerant charge	C/O	kg	6.8	7.0	9.0	9.5
	H/P	kg	8.0	8.2	11.5	12.0
Nett dimensions	Height	mm	1435	1435	1470	1470
	Length	mm	1950	1950	2200	2200
	Depth	mm	1450	1450	1750	1750
Nett weight	Cooling only models	kg	450	460	577	602
Nett weight	Heat pump models	kg	455	465	582	607

All the data are at EUROVENT conditions with 400V/3+N/50Hz.

Cooling : Entering indoor coil temp. 27°C / 19°C WB and outdoor temperature 35°C - Heating : Entering indoor coil temp. 20°C and outdoor temperature 7°C / 6°C WB
Sound pressure level measured in free field conditions at 1 m from the unit. According to ISO 3744.

Free-cooling with 2 dampers: D2 version

- It mixes some of the intake air with air taken outside of the room. The mixture percentage can be customised: from 0% (total air recirculation) to 50% outdoor air.
- The percentage of outdoor air to be introduced into the room can be managed either as a fixed value, by means of an appropriate controller parameter, or depending on air quality sensors connected to the unit (SQ,SQO, SQV accessories).
- The unit can operate in both Free-Cooling and Free-Heating operation.renewal system.

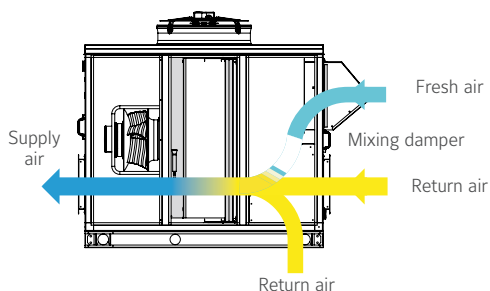

Free-cooling with 2 dampers and wheel heat recovery: D2 + RWH version

- It mixes some of the intake air with air taken outside of the room. The mixture percentage can be customised: from 0% (total air recirculation) to 50% outdoor air.
- The percentage of outdoor air to be introduced into the room can be managed either as a fixed value, by means of an appropriate controller parameter, or depending on air quality sensors connected to the unit (SQ,SQO, SQV accessories).
- The unit can operate in both Free-Cooling and Free-Heating operation.

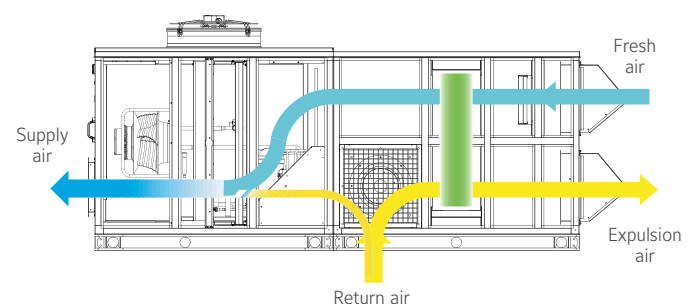

Manufacturer reserves the rights to change specifications without prior notice.

ACTIVA ASR Rooftop

Cooling capacity from 49.6 kW up to 219.1 kW

Heating capacity from 50.7 kW up to 212.6 kW



Consult us for available models



This new generation of high efficiency rooftop units have been thought and designed to reach the Ecodesign 2021 threshold. It reaches the energy class A. The ACTIVA ASR units are available in cooling-only (L) or reversible (H) versions and with a wide range of options.

Features

- High efficiency EER and COP
- Ecodesign ErP 2021 compliant
- H version (Cooling and Heating) or L version (Cooling only)
- 2 independent circuits & frigorific insulated box
- Many air inlet/outlet configurations
- Double skin as standard
- AC/EC Plug Fans for supply and extract air
- Removable drain pan
- Leak detection according to BREEM standard

Options and Accessories

- EC plug fans
- Sides, Top or Bottom supply/return air
- 2 filters stage G4+F7/F9 (flat type)
- Hot water coil or Electric Heater
- Gas burner
- 2 Dampers mixing section / Freecooling / IAQ (indoor air quality control)
- Food Refrigeration Heat Recovery (FRECO)
- Return fan & 3 Dampers (RECO)
- Return fan & 3 Dampers & Heat Recovery (TRECO)

ACTIVA ASR Rooftop

ASR 50 to 210



Technical features

Cooling Only models		ASR 50 L	ASR 65 L	ASR 80 L	ASR 95 L	ASR 105 L	ASR 120 L	ASR 140 L	ASR 160 L	ASR 190 L	ASR 210 L	
Nominal cooling capacities	kW	49.57	62.81	78.99	95.13	111.08	119.87	142.09	164.98	197.06	219.12	
Power input in cooling	kW	15.81	19.46	23.23	30.66	33.56	37.10	47.09	51.19	60.61	71.54	
SEER (1)		3.57	3.58	3.74	3.54	3.66	3.57	3.52	3.91	3.94	3.71	
$\eta_{s,c}$ (1)		140	140	147	138	143	140	138	154	154	145	
Heat Pump models		ASR 50 H	ASR 65 H	ASR 80 H	ASR 95 H	ASR 105 H	ASR 120 H	ASR 140 H	ASR 160 H	ASR 190 H	ASR 210 H	
Nominal cooling capacities	kW	48.12	60.95	76.67	92.34	107.81	116.34	137.88	160.10	191.21	212.6	
Power input in cooling	kW	15.81	19.46	23.23	30.66	33.56	37.10	45.69	51.19	60.61	70.47	
SEER (1)		3.53	3.52	3.63	3.52	3.55	3.52	3.52	3.80	3.82	3.65	
$\eta_{s,c}$ (1)		138.15	138	142.23	138	139.17	138	138	148.92	149.82	143.15	
Heating capacities	kW	50.65	59.65	76.63	90.66	106.95	117.10	148.70	157.90	187.31	214.37	
Power input in heating	kW	14.81	17.49	21.77	26.59	30.38	34.14	42.85	46.17	54.29	62.68	
SCOP (2)		3.20	3.22	3.22	3.23	3.22	3.21	3.20	3.19	3.23	3.19	
$\eta_{s,h}$ (2)		125	126	126	126	126	125	125	125	126	125	
Common characteristics												
Nominal airflow rate	m ³ /h	9 720	11 500	15 500	17 500	19 200	21 580	25 500	28 000	30 000	32000	
Nominal ESP	Pa	220	220	225	240	240	240	240	240	240	240	
Sound power level	dB(A)	81.5	85.0	82.0	83.0	85.4	87.4	91.3	90.5	91.5	92.4	
Refrigerant type		R410A										
Number of refrigerant circuits		2	2	2	2	2	2	2	2	2	2	
Compressor type		Scroll										
Number of compressors		2	2	2	2	2	2	2	4	4	4	
Step of capacity	%	0-50-100							0-25-50-75-100			
Glasswool thickness casing	mm	25	25	25	25	25	25	25	25	25	25	
Fire resistance		MO										
Weight standard unit	kg	1 085	1 155	1 225	1 470	1 685	1 805	1 855	2 350	2 555	2 705	

All the data are at EUROVENT conditions with 400V/3+N/50Hz.

Cooling : Entering indoor coil temp. 27°C / 19°C WB and outdoor temperature 35°C - Heating : Entering indoor coil temp. 20°C and outdoor temperature 7°C / 6°C WB

(1) According to EN 14511. (2) According to EN 14825.

Aeraulic configurations

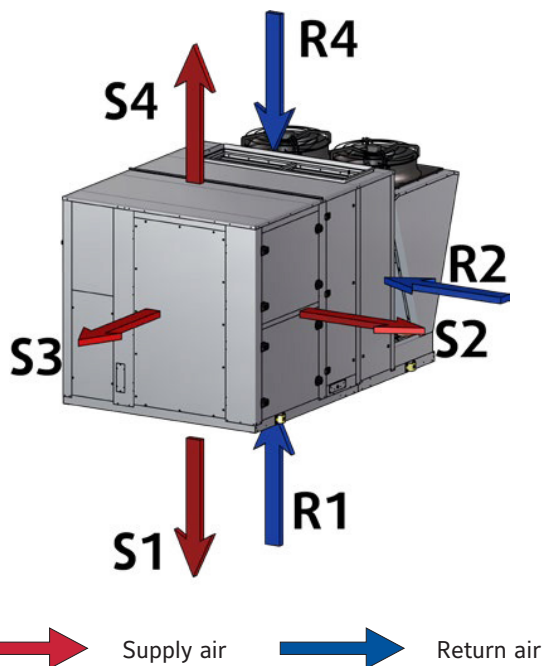

Many possibilities of configurations for Supply and Return air

Supply air	S1. Down supply air
	S2. Left supply air *
	S3. Front supply air
	S4. Up supply air*
Return air	R1. Down return air
	R2. Left return air
	R4. Up return air **

* S2 and S4 configurations not available with the gas burner option

** R4 configuration not available with RECO and TRECO options



Manufacturer reserves the rights to change specifications without prior notice.

Dimensions and Weights

ASR 50-80

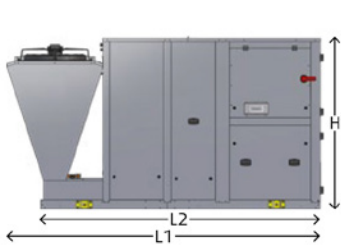

ASR 95-140

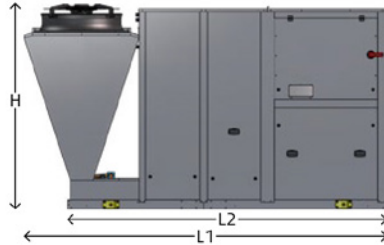

ASR 160-210

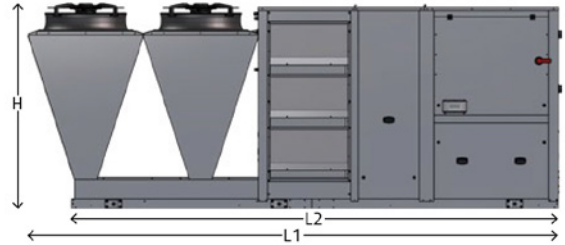

Dimensions

ASR models - Standard unit		50	65	80	95	105	120	140	160	190	210
(L1) Overall length	mm	3 250	3 250	3 250	3 740	3 740	3 740	3 740	5 505	5 505	5 505
(L2) Base frame length	mm	2 895	2 895	2 895	3 295	3 295	3 295	3 295	5 050	5 050	5 050
Width	mm	2 030	2 030	2 030	2 285	2 285	2 285	2 285	2 285	2 285	2 285
(H) Height	mm	1 800	1 800	1 800	2 110	2 110	2 110	2 110	2 110	2 110	2 110
ASR models - 3 Dampers		50	65	80	95	105	120	140	160	190	210
(L1) Overall length	mm	3 918	3 918	3 918	4 430	4 430	4 430	4 430	5 966	5 966	5 966
(L2) Base frame length	mm	3 525	3 525	3 525	3 980	3 980	3 980	3 980	5 470	5 470	5 470
Width	mm	2 626	2 626	2 626	2 760	2 760	2 760	2 760	3 044	3 044	3 044
(H) Height	mm	1 800	1 800	1 800	2 110	2 110	2 110	2 110	2 110	2 110	2 110
ASR models - Gas burner		50	65	80	95	105	120	140	160	190	210
(L1) Overall length	mm	3 395	3 395	3 395	3 892	3 892	3 892	3 892	6 015	6 015	6 015
(L2) Base frame length	mm	2 895	2 895	2 895	3 295	3 295	3 295	3 295	5 525	5 525	5 525
Width	mm	2 682	2 682	2 682	3 040	3 040	3 040	3 040	3 151	3 151	3 151
(H) Height	mm	2 080	2 080	2 080	2 285	2 285	2 285	2 285	2 110	2 110	2 110
ASR models - 3 Dampers + gas burner		50	65	80	95	105	120	140	160	190	210
(L1) Overall length	mm	4 022	4 022	4 022	4 566	4 566	4 566	4 566	6 466	6 466	6 466
(L2) Base frame length	mm	3 525	3 525	3 525	3 980	3 980	3 980	3 980	5 972	5 972	5 972
Width	mm	2 626	2 626	2 626	3 042	3 042	3 042	3 042	3 151	3 151	3 151
(H) Height	mm	1 935	1 935	1 935	2 454	2 454	2 454	2 454	2 110	2 110	2 110

Weights

ASR models - Standard unit		50	65	80	95	105	120	140	160	190	210
Unit weight	kg	1 085	1 155	1 225	1 470	1 685	1 805	1 855	2 350	2 555	2 705
Filters	G4	kg	30	30	30	45	45	45	45	45	45
	G4 + F7	kg	40	40	40	65	65	65	65	65	65
	G4 + F9	kg	40	40	40	65	65	65	65	65	65
2 Dampers	kg	95	95	95	115	115	115	115	165	165	165
3 Dampers RECO	kg	375	385	415	430	430	450	450	515	515	515
TRECO	kg	125	125	125	165	165	165	165	215	215	215
FRECO	kg	25	25	25	30	30	30	30	30	30	30
Electric heater	kg	25	25	25	30	30	30	30	50	50	50
Hot water coil	kg	25	25	25	30	30	30	30	30	30	30
Epoxy	kg	40	40	40	50	50	50	50	95	95	95
Gas Burner	kg	65	80	80	105	105	105	105	460	460	460

Energy recovery systems

FRECO - Food refrigeration energy RECOvery

In supermarkets, FRECO technology allows our rooftop units to recover the heat generated out from the condensers of the cooling systems.

Heating mode

	Additional heating capacity
Mixed air $T^{\circ} = 20^{\circ}\text{C}$	+60%
Mixed air $T^{\circ} = 0^{\circ}\text{C}$	+130%

Water +30% Glycol 45/40°C

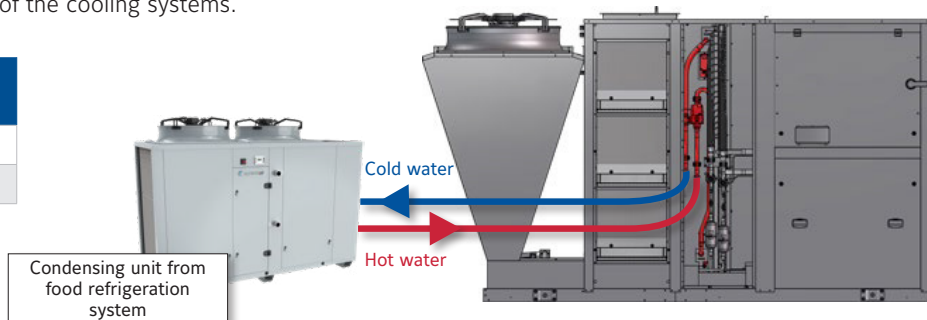

RECO - Standard energy RECOvery (3 Dampers)

Energy recovery on the exhaust air.

Heating mode

	Pc	EER	Ph	COP
3 dampers + RECO 30% fresh air	+1%	+2%	+7%	+4%
3 dampers + RECO 60% fresh air	+2%	+4%	+14%	+8%

According to Eurovent conditions

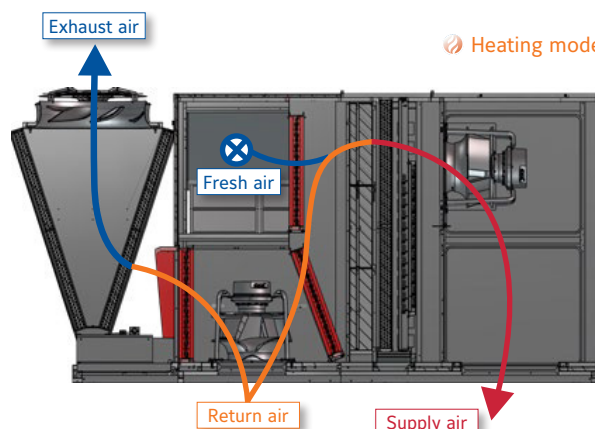

TRECO - Thermodynamic energy RECOvery (3 Dampers)

Active energy recovery between the exhaust air and the fresh air using dedicated thermodynamic system.

Heating mode

	Pc	EER	Ph	COP
3 dampers + TRECO 20% fresh air	+21%	0%	+20%	+3%
3 dampers + TRECO 60% fresh air	+20%	-2%	+21%	+4%

According to Eurovent conditions

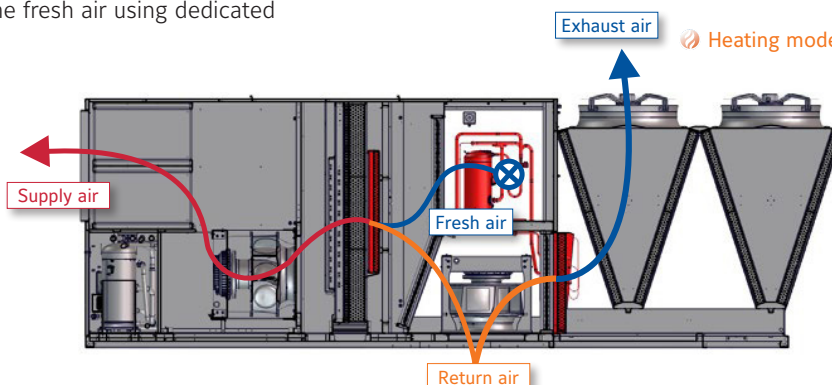

Large ACTIVA Rooftop

ARC-ARH 100 to 175 AB

A complete range from 108 kW up to 169 kW

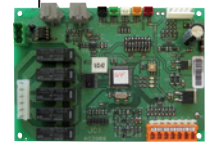

YKN2open

Features

- High efficiency EER and COP
- Ecodesign ErP 2021 compliant
- Quiet operation
- Configurations: Cooling only and Heating
- BMS communication as standard (N2Open protocol)
- Partial loads
- Extended working range (up to 52°C outdoor temperature)
- F6 & F7 filters available as option (G4 standard)
- Energy recovery (ask JCI for availability)

ARC 150 AB Nomenclature

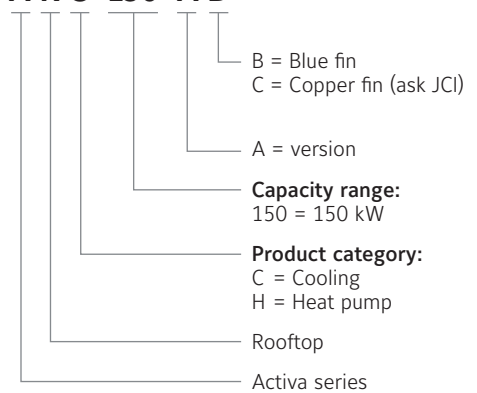

Large ACTIVA Rooftop

ARC-ARH 100 to 175 AB



Technical features

Cooling only models		ARC 100 AB	ARC 125 AB	ARC 150 AB	ARC 175 AB	
Net cooling capacities	kW	108.1	121.8	149.3	169.0	
Power input	kW	34	41	59	64	
SEER		4.95	4.58	3.72	3.53	
η _{s,c}		195.0	180.1	145.7	138	
Working range (full load / partial load) *	°C	7°C ~ 46°C / -10°C ~ 52°C				
Heat pump models		ARH 100 AB	ARH 125 AB	ARH 150 AB	ARH 175 AB	
Net cooling capacities	kW	108.1	121.8	149.3	169.0	
Power input in cooling	kW	34	41	59	64	
Heating capacities (1)	kW	104.6	118.4	147.0	167.0	
Power input in heating	kW	33	37	53	61	
SCOP		3.58	3.44	3.44	3.44	
η _{s,h}		140.2	134.5	134.6	134.5	
Working range (full load / partial load) *	°C	-10°C ~ 46°C / -10°C ~ 52°C				
Common characteristics						
Power supply	400V / 3 / 50Hz					
Main switch	A	100	125	160	200	
Main cable	Nbr. x mm ²	3 x 35	3 x 50	3 x 50	3 x 70	
Cable to thermostat	Nbr. x mm ²	10 x 0,22				
Number of circuits / Compressor type	2 (tandem) / 4 x scroll					
Evaporator fan at nominal airflow	Airflow	m ³ /h	19 000	21 000	27 000	31 000
	Power input	kW	3.0	3.3	8.3	9.1
Nett dimensions	Height	mm	2 142		2 142	
	Length	mm	4 036		5 085	
	Depth	mm	2 250		2 250	
Nett weight ARC	kg	1 737	1 744	2 074	2 090	
Nett weight ARH	kg	1 765	1 772	2 135	2 150	

All the data are at EUROVENT conditions with 400V/3+N/50Hz.

Cooling : Entering indoor coil temp. 27°C / 19°C WB and outdoor temperature 35°C - Heating : Entering indoor coil temp. 20°C and outdoor temperature 7°C / 6°C WB

(1) Add indoor fan motor consumption to know total heating capacity.

* With Premium kit (full load / partial load): -10°C ~ 50°C / -10°C ~ 52°C

Codes

Cooling only models	ARC 100 AB	ARC 125 AB	ARC 150 AB	ARC 175 AB
	S661852400	S661852420	S661852450	S661852480
Heat pump models	ARH 100 AB	ARH 125 AB	ARH 150 AB	ARH 175 AB
	S661852403	S661852423	S661852453	S661852483
Thermostat	to be ordered separately			
	DPC-1			



Manufacturer reserves the rights to change specifications without prior notice.

Large Activa rooftop details

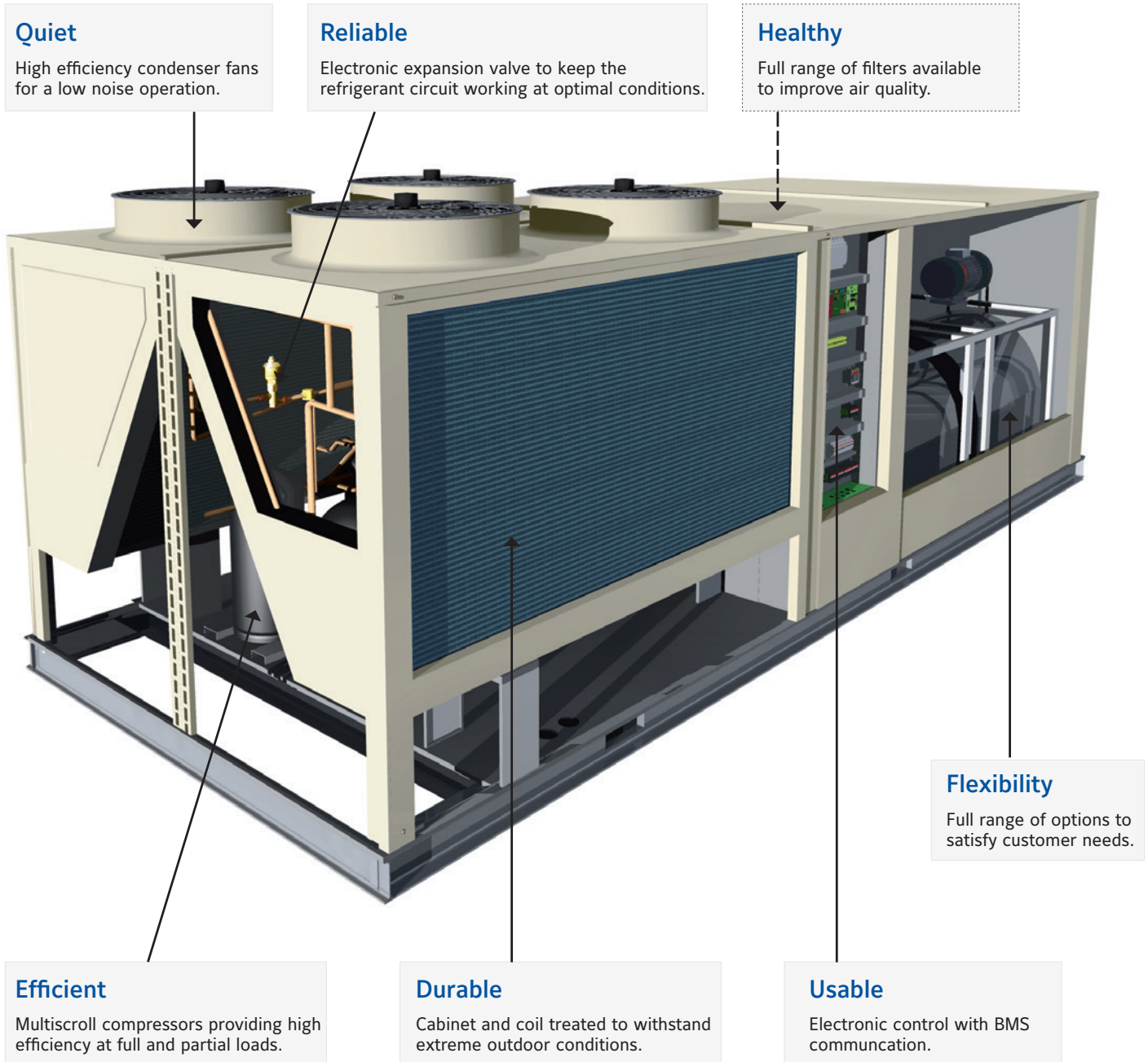

Accessories and options

		Code	Cooling only				Heat pump				
			100	125	150	175	100	125	150	175	
Thermostat DPC-1		S603786044	A	A	A	A	A	A	A	A	
YNK2Open Gateway BACnet / IP - JCI Metasys N2		S606791244	A	A	A	A	A	A	A	A	
YNK2Open Gateway Modbus TCP / IP - JCI Metasys N2		S606791245	A	A	A	A	A	A	A	A	
Dry bulb triple input economizer or motorized air damper with rain hood		S611751011	O	O			O	O			
		S611751511			O	O			O	O	
Enthalpy probes		S613990081	O	O	O	O	O	O	O	O	
Indoor air quality sensor		S606819964	O/A	O/A	O/A	O/A	O/A	O/A	O/A	O/A	
Power Exhaust		S611751021	A	A			A	A			
		S611751521			A	A			A	A	
Barometric relief damper		S611751031	A	A			A	A			
		S611751531			A	A			A	A	
Fresh air damper		S613751021	A	A			A	A			
		S613751521			A	A			A	A	
High pressure drive		7.5 kW (IE3)	S611751091	O	O			O	O		
		11 kW (IE3)	S611751093	O	O			O	O		
		5.5 kW (IE3)	S611751591			O				O	
		7.5 kW (IE3)	S611751592			O	O			O	O
Side duct supply		S611751061	O	O			O	O			
		S611751561			O	O			O	O	
Soft start indoor fan		5.5 kW	S606744690	O	O	O	O	O	O	O	
		11.5 kW	S606744691	O	O	O	O	O	O	O	O
Premium Kit (LAK included) *		S611751071	O	O	O	O	O	O	O	O	
Fixed roof curb		S611751081	A	A			A	A			
		S611751581			A	A			A	A	
Adjustable roof curb		S611751082	A	A			A	A			
		S611751582			A	A			A	A	
Dirty filter switch		S613990085	O	O	O	O	O	O	O	O	
Smoke detector		S613995382	O	O	O	O	O	O	O	O	
Fire detection thermostat		S613903003	O	O	O	O	O	O	O	O	
Hot water coil		S611751051	O	O			O	O			
		S611751551			O	O			O	O	
Electric heaters		37 kW	S611751037	O	O	O	O	O	O	O	
		50 kW	S611751050	O	O	O	O	O	O	O	
		60 kW	S611751060	O	O	O	O	O	O	O	O
Filter kit F6		S611751046	O	O			O	O			
		S611751546			O	O			O	O	
Filter kit F7		S611751047	O	O			O	O			
		S611751547			O	O			O	O	
Grill condenser coil protection		S611751041	O	O			O	O			
		S611751541			O	O			O	O	
Antivibration mounting kit 100/125		S613751011	O	O			O	O			
Antivibration mounting kit 150/175		S613751511			O	O			O	O	
Alarm relay board		S606791243	O/A	O/A	O/A	O/A	O/A	O/A	O/A	O/A	
Copper-copper coil		Contact us	O	O	O	O	O	O	O	O	

O=Option (factory fitted). A=Accessory (supplied loose). O/A=If you want this item factory fitted, precise it in the order form.

(1) = Energy recovery accessory includes: economizer, rain hood, indoor air quality sensor and G4 filters.

* Features: increased efficiency by 0.15, extended max outdoor temperature up to +50°C at full load, Low ambient kit.

YORK Fan Coil units

Driven by innovative trends and modern technology, the YORK Fan Coil Units have been designed around a platform of models, versions and accessories, which have been independently tested and certified by Eurovent. The YORK Fan Coil range meets today's demanding requirements of performance, size, acoustics, low energy, ease of installation and maintenance.



An extensive offering

- One of the **most versatile** ranges of fan coils on the market today. Wall and ceiling mounted units, exposed or concealed with centrifugal fan, are included, and with cooling capacities ranging from 0.6 kW to 9.7 kW.
- Dramatic **electrical consumption reduction** of up to 40% comparative to previous models. This is achieved thanks to the supply of all YORK Fan Coil Units equipped with centrifugal fans and electric motors, and with 6 speed motors as standard to offer greater flexibility in the selection of products.
- Energy saving brushless motor** technology option available. Its combination with a dedicated frequency inverter and unit controller to regulate the fan speed enables higher efficiencies, even at low rotational speeds, lower unit noise, constant speed characteristics and an increase in motor lifetime expectancy. In comparison to the traditional units equipped with asynchronous three-speed-motors, units with brushless motors can obtain a considerable energy saving, by reducing the power consumption by up to 70%.
- A full range of **factory fitted Johnson Controls valve and pre-configured control options** is offered. This in addition to a patented 'wireless' control option - offering greater flexibility in the installation of units, with the highest precision in monitoring and maintaining the desired comfort conditions.
- Many of our ranges are available configured for use with 60Hz voltage, and specially designed cooling coils for **District Cooling applications**.
- High pressure 'Blower' units** are also available. They can offer up to 29.4 kW of cooling at External Static Pressures of up to 250Pa, and are complemented with a full range of options and accessories covering items such as electrical heating battery, air inlet/outlet diffusers and condensate pumps.



Iconography



Infrared or
Wired control



Wired
control



Dry mode



Timer



Auto
Restart



Sleep
mode



Auto
Sweep



Ducted
Installation



4 Way
Air Flow



Air Filter

YFCN Fan Coil Unit with centrifugal fan

2 & 4 pipe system

A complete range from 0.7 kW to 7.4 kW



YFCN is a range of Fan Coil Units that continues the YORK tradition based on high reliability and low noise levels. It is the result of great commitment in terms of energy and resources to offer a more modern product from every angle, while still delivering the convenience of easy access to the filters in all models.

Moreover each version has the same internal structure, identical in both horizontal and vertical models, in order to standardise production and guarantee a greater flexibility in distribution and installation.



Selection software

Wired controls

T9000 Series

Red Dot Product Design Award Winner 2020

- Touch Screen Display
- 2 or 4 pipes FCU
- 3-speed motors or ECM motors
- 2-wiring/3-wiring on/off valves or proportional valves
- Relay designed for 100,000 switching cycles
- Modbus or BACnet protocols



T7600 Series

- LCD Screen Display
- 2 or 4 pipes FCU
- On/off or proportional
- 3-speed motors or ECM motors
- Modbus RTU



Infrared control



TUC03+ Terminal unit controller

BacNET and N2 Metasys network compatible



Features

- New casing, improved aesthetics, suitable for any modern indoor ambient
- Full range for all needs: 9 sizes suitable for horizontal or vertical mounting with or without casing
- Low noise operation
- 3 fan speeds (possible choice between 6 fan speeds)
- Single piece discharge grid
- Several coil choices.
 - Single: 3 or 4 rows; Dual: 3 rows cooling and 2 rows heating
- Electrical heater optional
- Suction and discharge plenum optional
- Factory fitted valve (on/off or modulating) and controller packages
- Painted back panel option
- 4 available versions in all range:
 - VC = Vertical Discharge with Casing
 - VCB = Vertical Discharge with Casing (floor installation)
 - HC = Horizontal Discharge with Casing
 - CD = Concealed unit without Casing
- EUROVENT Certified

YFCN Fan Coil Unit with centrifugal fan

0.7 kW to 7.4 kW

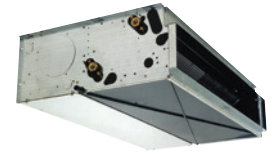

Technical features

YFCN model (2 pipes)		140	240	340	440	540	640	740	840	940	
Total cooling capacity [kW]	(1)	max	1.20	1.78	2.53	3.08	4.03	4.71	5.48	6.34	7.42
		med	1.00	1.41	1.87	2.25	3.21	3.81	4.56	5.63	6.41
		min	0.65	1.00	1.63	1.81	2.17	2.79	3.51	3.97	4.79
Sensible cooling capacity [kW]	(1)	max	0.94	1.35	1.86	2.30	3.01	3.52	4.13	4.93	5.87
		med	0.77	1.05	1.36	1.65	2.36	2.81	3.39	4.33	4.98
		min	0.49	0.73	1.18	1.32	1.58	2.03	2.57	2.98	3.63
Pressure drop in cooling [kPa]	(1)	max	5.6	13.9	11.5	15.5	31.3	36.2	27.7	32.2	23.2
		med	4	9.1	6.7	9	20.8	24.8	20	26.0	17.8
		min	1.9	4.9	5.3	6.1	10.4	14.4	12.5	14.0	10.6
Heating capacity [kW]	(2)	max	1.31	1.83	2.59	3.14	4.01	4.92	5.59	7.20	8.52
		med	1.07	1.43	1.87	2.27	3.16	3.90	4.62	6.27	7.18
		min	0.69	0.99	1.62	1.80	2.10	2.82	3.49	4.26	5.23
Pressure drop in heating [kPa]	(2)	max	5.3	11.8	9.8	12.8	25.2	31.8	23.2	31.7	23.7
		med	3.7	7.6	5.4	7.2	16.6	21.1	16.6	24.9	17.6
		min	1.7	4.0	4.2	5.0	8.1	11.9	10.1	12.8	10.0
Air flow [m³/h]		max	220	295	385	485	650	760	925	1 200	1 500
		med	175	220	270	335	495	590	735	1 020	1 210
		min	105	145	235	265	315	415	535	655	830
Fan [W]		max	33	32	41	44	46	78	103	130	176
		med	25	22	25	28	39	55	79	105	134
		min	16	14	20	21	22	37	54	62	92
Sound power level [dB(A)]		max	45	47	49	47	48	52	56	60	64
		med	39	40	40	39	41	46	51	56	58
		min	32	30	36	33	31	37	42	45	50
Sound pressure level [dB(A)]	(4)	max	36	38	40	38	39	43	47	51	55
		med	30	31	31	30	32	37	42	47	49
		min	23	21	27	24	22	28	33	36	41
Power supply [V-ph-Hz]		230 / 1 / 50 + E									
Dimensions *	Height	mm	530	530	530	530	530	530	530	530	530
	Width	mm	670	770	985	985	1 200	1 200	1 415	1 415	1 415
	Depth	mm	225	225	225	225	225	225	225	255	255

YFCN model (4 pipes)		140+1	240+1	340+1	440+1	540+1	640+1	740+1	840+1	940+1	
Total cooling capacity [kW]	(1)	max	1.20	1.78	2.53	3.08	4.03	4.71	5.48	6.34	7.42
		med	1.00	1.41	1.87	2.25	3.21	3.81	4.56	5.63	6.41
		min	0.65	1.00	1.63	1.81	2.17	2.79	3.51	3.97	4.79
Sensible cooling capacity [kW]	(1)	max	0.94	1.35	1.86	2.30	3.01	3.52	4.13	4.93	5.87
		med	0.77	1.05	1.36	1.65	2.36	2.81	3.39	4.33	4.98
		min	0.49	0.73	1.18	1.32	1.58	2.03	2.57	2.98	3.63
Pressure drop in cooling [kPa]	(1)	max	5.6	13.9	11.5	15.5	31.3	36.2	27.7	32.2	23.2
		med	4	9.1	6.7	9	20.8	24.8	20	26.0	17.8
		min	1.9	4.9	5.3	6.1	10.4	14.4	12.5	14.0	10.6
Heating capacity [kW]	(3)	max	0.91	1.33	1.99	2.33	3.00	3.33	4.20	4.75	5.46
		med	0.77	1.09	1.56	1.81	2.50	2.79	3.59	4.26	4.79
		min	0.55	0.83	1.40	1.52	1.84	2.19	2.89	3.16	3.71
Pressure drop in heating [kPa]	(3)	max	1.3	3.1	7.8	10.3	2.6	3.8	6.7	8.3	10.7
		med	1.0	2.2	5.1	6.6	2.3	2.8	5.1	6.9	8.5
		min	0.5	1.3	4.2	4.9	1.3	1.8	3.5	4.1	5.4
Air flow [m³/h]		max	330	515	505	735	720	890	875	1 395	1 365
		med	220	350	340	495	475	610	585	945	910
		min	120	210	200	305	290	400	380	605	575

(1) Room temperature 27°C d.b., 19°C w.b. - Water temperature 7/12 °C.

(2) Room temperature 20°C - Water temperature 45/40 °C. (3) Room temperature 20°C - Water temperature 65/55 °C.

(4) The sound pressure levels are 9 dB(A) lower than the sound power levels and apply to the reverberant field of a 100 m³ room and a reverberation time of 0.5 sec.

* Dimensions refer to the units with casing.

Data shown is for 4 row cooling version.

For performance of 3 row cooling version please contact your local Johnson Controls sales office.



Manufacturer reserves the rights to change specifications without prior notice.

ECM Technology



Running costs. Energy consumption. Life cycle.

These are 3 issues that are becoming more and more important in the choice of Fan Coil Units. With these criteria in mind, Johnson Controls offers the ECM range of FCU.

ECM technology comprises a **brushless motor** combined to a **dedicated electronic device** (inverter). In comparison to conventional units equipped with asynchronous three-speed motors, the fancoil and cassette units with brushless motors can obtain a considerable energy saving, by **reducing power consumption up to 70%**.

Air flow rate can be varied in continuous by means of a 0-10V signal generated both by our controls or by independent controls systems. The continuous air flow control improves the **acoustic comfort** and allows a more punctual reply to the variation of the thermal loads, enhancing the **stability of ambient temperature**.

Technology

ECM technology consists of a brushless motor combined with an inverter managed by specific regulators. The controller uses a 0-10 VDC modulating signal to regulate the fan speed.

The brushless electric motor is composed of a rotor having permanent magnets, whose magnetic fields interact with the ones produced by the stator winding. The **transfer of current is no longer by mechanical commutator** (sliding contacts) **but by an electronic commutation system**: one electronic controller (inverter) powers the motor's stator and generates rotating magnetic fields, that in turn determine the rotor's speed.

Brushless motor develop much less heat than the traditional brushed motors and they have much lower mechanical resistance than the standard asynchronous maintenance. The absence of brushes eliminates also the main source of electromagnetic noise.

Power consumption: YFCN versus YFCN-ECM (W/kW)

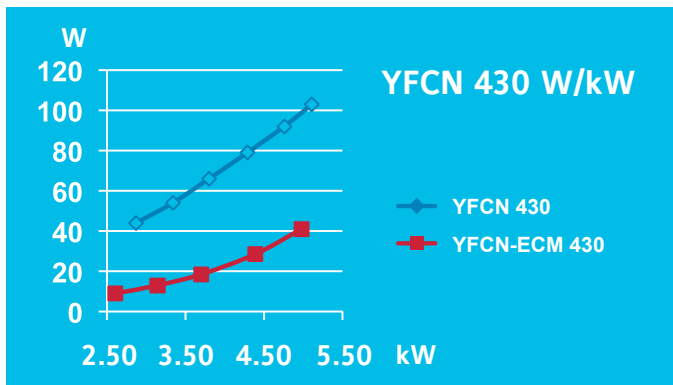

Features

- Brushless motor with inverter.
- 0-10VDC control signal.
- Low mechanical resistance and heat gain
- Continuous regulation of the fan speed.
- Specifically designed electronic and digital regulators, also for BMS systems.
- Possibility to manually set the desired three fan speeds (MIN/MED/MAX).

Advantages (compared to traditional brushed motors)

- Energy saving: electrical absorption reduced up to 70%.
- Higher efficiency: possibility to adapt the air volume and the capacities accordingly to the actual room loads.
- Higher comfort: reduced variation of the temperature and relative humidity in the room.
- Extremely quiet operation.
- Reduced wear and higher reliability.
- Longer life expectancy of the motor.

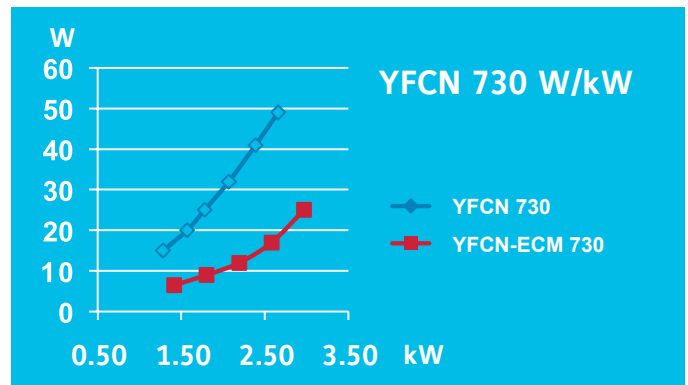

YFCN-ECM Inverter Fan Coil Unit with centrifugal fan

0.7 kW to 7.1 kW



Technical features

YFCN-ECM model (2 pipes)			230	240	430	440	630	640	730	740	930	940
Total cooling capacity [kW]	(1)	max 10v	1.59	1.86	2.95	3.17	3.96	4.51	4.94	5.30	6.26	7.04
		med 5v	1.18	1.32	2.18	2.27	2.93	3.19	3.68	3.82	4.82	5.21
		min 1v	0.73	0.77	1.41	1.43	1.96	2.05	2.60	2.61	3.45	3.59
Sensible cooling capacity [kW]	(1)	max	1.28	1.42	2.26	2.39	3.08	3.38	3.80	3.99	5.10	5.53
		med	0.92	0.98	1.64	1.67	2.22	2.34	2.77	2.82	3.79	3.99
		min	0.55	0.56	1.03	1.03	1.46	1.48	1.92	1.90	2.63	2.69
Pressure drop in cooling [kPa]	(1)	max	8.6	14.8	28.9	16.1	19	33	32.6	25.6	25.9	20.8
		med	5.1	8	17	8.9	11.1	17.8	19.4	14.3	16.1	12.1
		min	2.2	3.2	7.9	4	5.5	8.2	10.5	7.3	8.9	6.3
Heating capacity [kW]	(2)	max	1.80	1.98	3.14	3.32	4.14	4.68	5.08	5.43	7.38	7.93
		med	1.29	1.37	2.26	2.30	3.00	3.23	3.72	3.84	5.41	5.63
		min	0.77	0.78	1.42	1.42	1.96	2.02	2.56	2.57	3.74	3.76
Pressure drop in heating [kPa]	(2)	max	7.0	13.6	26.7	13.7	17.0	29.1	28.3	22.0	24.2	20.9
		med	3.9	7.1	14.9	7.3	9.6	15.1	16.4	12.0	14.0	11.4
		min	1.6	2.6	6.6	3.1	4.5	6.6	8.5	5.9	7.3	5.6
Air flow [m³/h]		max	330	325	515	505	735	720	890	875	1 395	1 365
		med	220	210	350	340	495	475	610	585	945	910
		min	120	115	210	200	305	290	400	380	605	575
Fan [W]		max	21	21	25	25	32	32	41	41	99	99
		med	11	11	12	12	15	15	19	19	41	41
		min	7	7	6	6	7	7	9	9	16	16
Sound power level [dB(A)]		max	51	51	51	51	54	54	57	57	64	64
		med	41	41	42	42	44	44	48	48	55	55
		min	30	30	30	32	33	33	37	37	44	44
Sound pressure level [dB(A)]	(4)	max	42	42	42	42	45	45	48	48	55	55
		med	32	32	33	33	35	35	39	39	46	46
		min	21	21	21	23	24	24	28	28	35	35
Power supply [V-ph-Hz]			230 / 1 / 50 + E									
Dimensions *	Height	mm	530	530	530	530	530	530	530	530	530	530
	Width	mm	770	770	985	985	1 200	1 200	1 415	1 415	1 415	1 415
	Depth	mm	225	225	225	225	225	225	225	225	255	255

YFCN-ECM model (4 pipes)			230+1	240+1	430+1	440+1	630+1	640+1	730+1	740+1	930+1	940+1
Total cooling capacity [kW]	(1)	max 10v	1.59	1.86	2.95	3.17	3.96	4.51	4.94	5.30	6.26	7.04
		med 5v	1.18	1.32	2.18	2.27	2.93	3.19	3.68	3.82	4.82	5.21
		min 1v	0.73	0.77	1.41	1.43	1.96	2.05	2.60	2.61	3.45	3.59
Sensible cooling capacity [kW]	(1)	max	1.28	1.42	2.26	2.39	2.88	3.38	3.80	3.99	5.10	5.53
		med	0.92	0.98	1.64	1.67	2.08	2.34	2.77	2.82	3.79	3.99
		min	0.55	0.56	1.03	1.03	1.37	1.48	1.92	1.90	2.63	2.69
Pressure drop in cooling [kPa]	(1)	max	9.40	14.8	28.10	16.1	23.30	33	31.80	25.6	25.90	20.8
		med	5.40	8.0	16.00	8.9	13.20	17.8	18.40	14.3	16.10	12.1
		min	2.30	3.2	7.30	4.0	6.40	8.2	9.70	7.3	8.90	6.3
Heating capacity [kW]	(3)	max	1.43	1.43	2.41	2.41	3.22	3.22	4.06	4.06	5.24	5.24
		med	1.08	1.08	1.85	1.85	2.45	2.45	3.13	3.13	4.05	4.05
		min	0.71	0.71	1.29	1.29	1.76	1.76	2.33	2.33	2.99	2.99
Pressure drop in heating [kPa]	(3)	max	3.5	3.5	11.0	3.5	3.6	3.6	6.3	6.3	9.9	9.9
		med	2.1	2.1	6.9	2.1	2.2	2.2	4.0	4.0	6.3	6.3
		min	1.0	1.0	3.6	1.0	1.2	1.2	2.4	2.4	3.7	3.7
Air flow [m³/h]		max	330	325	515	505	735	720	890	875	1 395	1 365
		med	220	210	350	340	495	475	610	585	945	910
		min	120	115	210	200	305	290	400	380	605	575

(1) Room temperature 27°C d.b., 19°C w.b. - Water temperature 7/12 °C

(2) Room temperature 20°C - Water temperature 45/40 °C

(3) Room temperature 20°C - Water temperature: 65/55°C

(4) The sound pressure levels are 9 dB(A) lower than the sound power levels and apply to the reverberant field of a 100 m³ room and a reverberation time of 0.5 sec.

* Dimensions refer to the units with casing



Manufacturer reserves the rights to change specifications without prior notice.

Options / Accessories

Compatibility table / Codes

Model	YFCN AC motor control devices		
	VC/VCB model Vertical with casing	HC model Horizontal with casing	CD model Without casing
Controls for style VC (supplied with separate packaging)			
Three speed control MV-3V (1)	9060130	-	-
Three speed control + electronic thermostat and S/W switch TMV-S (2)	9060140	-	-
Three speed control + electronic thermostat and centralized S/W - TMV-C (2)	9060133	-	-
Automatic speed control with electronic thermostat and S/W switch TMV-AUT (2)	9066319	-	-
Controls for style HC/CD (supplied with separate packaging)			
Remote three speed control WM-3V (1) (4)	-	9066642	9066642
Remote three speed control + electronic thermostat JWC-T and manual S/W switch (2)	-	9066630K	9066630K
Remote three speed control + electronic thermostat and centralized/manual S/W switch JWC-TQR (2) (3)	-	9066631K	9066631K
Automatic speed control with electronic thermostat and S/W switch - JWC-AU (to be used with UPM-AU and UP-AU only) (2) (3)	-	9066632K	9066632K
Automatic remote control with electronic thermostat, S/W switch and liquid crystal display T-MB (to be used with UPM-AU and UP-AU) (2) (3)	-	9066331E	9066331E
Automatic speed control with electronic thermostat to be mounted in the light wall box WM-503-AC-EC (to be used with UP-503-AC-EC only)	-	9066686E	9066686E
Electromechanical thermostat T2T (4) (5)	-	9060174	9060174
Power unit UPM-AU for JWC-AU and T-MB remote controls, fitted on the unit	9066641	9066641	9066641
Power unit UP-AU for JWC-AU and T-MB remote controls, not fitted on the unit	9066640	9066640	9066640
Power unit UP-503-AC-EC for WM-503-AC-EC remote control only, not fitted on the unit	9066687	9066687	9066687
Controls accessories for all versions (supplied with separate packaging)			
Low temperature cut-out for controls TME	3021091	3021091	3021091
Low temperature cut-out for controls TMV-S, WM-3V and JWC-T	9053048	9053048	9053048
Low temperature cut-out for controls TMV-AUT, TMV-AUT-E, JWC-TQR, WM-503-AC-EC and UP-AU power unit	3021090	3021090	9053049
T2 sensor to be used as Change-over for controls TMV-AUT, TMV-AUT-E and UP-AU power unit	9025310	9025310	9025310
Change-over 15-25 for control TMV-C and JWC-TQR	9053049	9053049	9053049
Receiving speed selector for centralized control (slave) SEL-V (for VC/VCB units)	9060136	-	-
Receiving speed selector for centralized control (slave) SEL-CR (for HC/CD units)	9066311	9066311	9066311
Terminal board adaptor kit KIT	9060103	-	-
Controls for style VC + additional electric resistance (supplied with separate packaging)			
Three speed control with electronic thermostat and S/W switch TMV-R-IAQ	9063006	-	-
Automatic speed control with electronic thermostat and S/W switch TMV-AUT-E (2) (3)	9066643	-	-
Controls for style HC/CD + additional electric resistance (supplied with separate packaging)			
Remote three speed control + electronic thermostat and centralized/manual S/W switch JWC-TQR (2) (3)	-	9066631K	9066631K
Automatic speed control with electronic thermostat and centralized S/W - JWC-AU (for UP-AU) (2) (3)	-	9066632K	9066632K
Automatic remote control with electronic thermostat, S/W switch and liquid crystal display T-MB (for UP-AU) (2) (3)	-	9066331E	9066331E

WARNING

(1) Not to be used with valves. (2) Can be used with valves and/or low temperature cut-out. (3) Can be used with Change Over.
 (4) Not suitable with -E electric heater. (5) To be used with valve and not to be used with low temperature cut-out.

Options / Accessories

Compatibility table / Codes

Model	YFCN AC motor control devices
Versions	ALL VERSIONS: VC/VCB - Vertical w. casing + HC - Horizontal with casing + CD without casing ALL VERSIONS: VC/VCB + HC + CD with electric heater

Controls and accessories for all versions

Mounted power unit MB-M	9066332
Not mounted power unit MB-S	9066333
Wall control T-MB	9066331E
IR remote control and mounted IR receiver RM-RT03	9066336
IR remote control and not mounted IR receiver RS-RT03	9066337
IR remote control RT03	3021203
Mounted IR receiver RM	9066339
Not mounted IR receiver RS	9066338
Multifunction wall control up to 60 units PSM-DI	3021293
T2 sensor (to be used as Change-over or minimum temp. Sensor)	9025310

Management system for a network of fan coils with MB electronic board

Hardware/software supervisory system (to be used with MB board only) NET	9079118
Router-S for NET (default) or for BMS systems not provided by YORK	3021290
Relay output board SIOS	3021292

With T-MB wall control

One control for each unit

(Maximum length of the connection cable = 20 m)



One control for more units in master/slave configuration (20 units max.)

(Maximum total length of the connection cable = 800 m)



With RT03 Infra-red remote control

One control for each unit



One control for more units in master/slave configuration (20 units max.)

(Maximum total length of the connection cable = 800 m)



Options / Accessories

Compatibility table / Codes

Model	YFCN ECM motor control devices		
Versions	VC/VCB model Vertical with casing	HC model Horizontal with casing	CD model Without casing
Controls accessories for all versions (supplied with separate packaging)			
Low temperature cut out NTC for control TMV-T-ECM, WM-S-ECM and UP-AU power unit		3021090	
T2 sensor to be used as Change -over for UP-AU power unit		9025310	
Change over CH 15-25 for control TMV-T-ECM		9053049	
Controls for style VC (supplied with separate packaging)			
Continuous fan speed control with electronic thermostat and S/W switch TMV-T-ECM (for standalone units - not for MB)	9060141	-	-
Controls for style HC/CD (supplied with separate packaging)			
JWC-AU Automatic speed control with electronic thermostat and centralized S/W switch (not for MB) (1) (2)	-	9066632K	9066632K
T-MB Automatic remote control with electronic thermostat, S/W switch and liquid crystall display (1) (2)	-	9066331E	9066331E
WM-S-ECM Continuous fan speed control with S/W switch and liquid crystall display (for standalone units - not for MB)	-	9066644	9066644
UPM-AU power unit for JWC-AU and T-MB remote controls, fitted on the unit (not MODBUS)	9066641	9066641	9066641
UP-AU power unit for JWC-AU and T-MB remote controls, not fitted on the unit (not MODBUS)	9066640	9066640	9066640
Accessories of controls for VC, HC-VCB and CD models (supplied with separate packaging)			
MB-ECM-M mounted power unit for ECM fan coil	9066334	9066334	9066334
MB-ECM-S not mounted power unit for ECM fan coil	9066335	9066335	9066335
Wall control T-MB	9066331E	9066331E	9066331E
IR remote control and mounted IR receiver RM-RT03	9066336	9066336	9066336
IR remote control and not mounted IR receiver RS-RT03	9066337	9066337	9066337
IR remote control RT03	3021203	3021203	3021203
Mounted IR receiver RM	9066339	9066339	9066339
Not mounted IR receiver RS	9066338	9066338	9066338
Multifunction wall control up to 60 units PSM-DI	3021293	3021293	3021293
T2 sensor (to be used as Change-over or minimum temperature Sensor)	9025310	9025310	9025310
Management system for a network of fan coils with MB electronic board			
Hardware / software supervisory system Net	9079118	9079118	9079118
Router-S for NET (default) or for BMS systems not provided by YORK	3021290	3021290	3021290
Relay output board SIOS	3021292	3021292	3021292

(1) Can be used with valves and/or low temperature cut-out. (2) Can be used with Change Over.

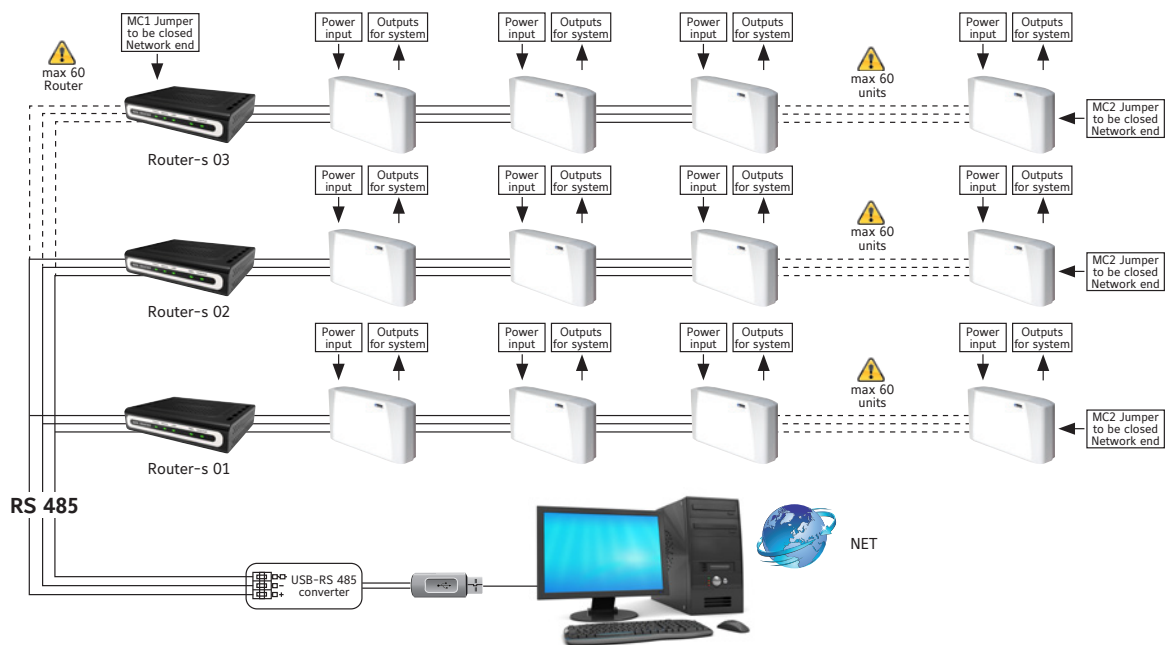

Options / Accessories

Compatibility table / Codes

Model	YFCN General accessories								
	130/140	230/240	330/340	430/440	530/540	630/640	730/740	830/840	930/940
Valves all versions									
3 way double valve kit for 4 tube installation and single coil + kit fitted on the unit					9066572W				
3 way double valve kit for 4 tube installation and single coil + kit not fitted on the unit					9066562W				
Kit 3 way valve mounted			9066561			9060471			
Kit 3 way valve additional battery mounted					9060472				
Kit 3 way valve not mounted			9066560			9060474			
Kit 3 way valve additional battery not mounted					9060475				
Kit 2 way valve primary and/or additional battery mounted (*)			9060476			9060476 (*)			
Kit 2 way valve primary battery mounted			-			9060477			
Kit 2 way valve primary and/or additional battery not mounted (*)			9060478			9060478 (*)			
Kit 2 way valve primary battery not mounted			-			9060479			
Valves CD versions only									
Simplified 3-way valve kit for CD version fitted			9066571			9060484			
Simplified 3-way valve kit for CD version not fitted			9066570			9060481			
Simplified 3-way valve kit for CD version fitted - additional battery					9060483				
Simplified 3-way valve kit for CD version not fitted - additional battery					9060480				
Electric heater VC/VCB/CH version									
El. resistance and relays fitted on the unit (700 W) VC/HC	9066491E					-			
El. resistance and relays fitted on the unit (400 W) VC/HC	-	9066472E					-		
El. resistance and relays fitted on the unit (600 W) VC/HC	-	9066482E		9066473E					
El. resistance and relays fitted on the unit (750 W) VC/HC			-		9066475E		-		
El. resistance and relays fitted on the unit (900 W) VC/HC	-		9066483E					-	
El. resistance and relays fitted on the unit (1000 W) VC/HC	-	9066492E		-			9066477E		
El. resistance and relays fitted on the unit (1250 W) VC/HC			-		9066485E		-		
El. resistance and relays fitted on the unit (1500 W) VC/HC	-		9066493E		-		9066487E		
El. resistance and relays fitted on the unit (2000 W) VC/HC			-		9066495E		-		
El. resistance and relays fitted on the unit (2500 W) VC/HC			-			9066497E			
Electric heater CD version									
El. resistance and relays fitted on the unit (700 W) CD	9066611					-			
El. resistance and relays fitted on the unit (400 W) CD	-	9066592					-		
El. resistance and relays fitted on the unit (600 W) CD	-	9066602		9066593					
El. resistance and relays fitted on the unit (750 W) CD			-		9066595		-		
El. resistance and relays fitted on the unit (900 W) CD	-		9066603					-	
El. resistance and relays fitted on the unit (1000 W) CD	-	9066612		-			9066597		
El. resistance and relays fitted on the unit (1250 W) CD			-		9066605		-		
El. resistance and relays fitted on the unit (1500 W) CD	-		9066613		-		9066607		
El. resistance and relays fitted on the unit (2000 W) CD			-		9066615		-		
El. resistance and relays fitted on the unit (2500 W) CD			-			9066617			

(*) For additional battery sizes 6 to 9.

Options / Accessories

Compatibility table / Codes

Model	YFCN General accessories									
	130/140	230/240	330/340	430/440	530/540	630/640	730/740	830/840	930/940	
Accessories for all versions										
Pair feet	9060150						9060151			
Vertical auxiliary condensate tray					6060400					
Horizontal auxiliary condensate tray for HC (left connections)					6060402					
Horizontal auxiliary condensate tray for HC (right connections)					6060403					
Horizontal auxiliary condensate tray for CD					6066039					
Condensate pump for VC - VCB - CD fitted on the unit auxiliary condensate collection tray included (vertical installation)					9066297					
Condensate pump for VC - VCB - CD not fitted on the unit auxiliary condensate collection tray included (vertical installation)					9066296					
Condensate pump for CD fitted on the unit auxiliary condensate collection tray to be ordered separately (horizontal installation)					9066298					
Condensate pump for CD not fitted on the unit auxiliary condensate collection tray included (horizontal installation)					9066180					
Condensate drain pipe	6060420									
Damper for CD model	9066531	9066532	9066533	9066534	9066535	9066536	9066537	9066538	9066539	
Damper for VC model	9076331	9076332	9076333	9076334	9076335	9076336	9076337	9076338	9076339	
Kit breeze	-	9076452	9076453	9076454	9076455	9076456	9076457	-	-	
Recessed box for kit breeze	-	9076462	9076463	9076464	9076465	9076466	9076467	-	-	
Rear closing panel VC	9062005	9060180	9060181	9060182	9060183	9060184	9060185	9060183		
Rear closing panel HC	9060187	9060190	9060191	9060192	9060193	9060194	9060195	9060196	9060197	
Frontal air intake CD mounted	9066501	9066502	9066503	9066504	9066505	9066506	9066507	9066508	9066509	
Intake grid for VC with feet	9066541	9066542	9066543	9066544	9066545	9066546	9066547	9066548	9066549	
Accessories only for concealed version CD										
Outlet flange 90° FM90	9066381	9066382	9066383	9066384	9066385	9066386	9066387	9066388	9066389	
Inlet flange 90° FR90	9066441	9060710	9060711	9060712	9060713	9060714	9060715	9060716	9060717	
Straight inlet flange FRD	9066451	9060720	9060721	9060722	9060723	9060724	9060725	9060726	9060727	
Straight outlet flange FMD	9066371	9066372	9066373	9066374	9066375	9066376	9066377	9066378	9066379	
Outlet spigot diffuser PMC	9066361	9066362	9066363	9066364	9066365	9066366	9066367	9066368	9066369	
Air outlet grid BMA	9066411	9060750	9060751	9060752	9060753	9060754	9060755	9060756	9060757	
Air inlet grid GRAG	9066431	9060764	9060765	9060766	9060767	9060768	9060769	9060770	9060771	
Air inlet grid GRAP	9066421	9060760	9060761	9060762	9060763	9060764	9060765	9060766	9060767	
Air inlet spigot plenum PRC	9066461	9066462	9066463	9066464	9066465	9066466	9066467	9066468	9066469	
Intake grid with filter (to be used in combination with inlet flange 90°) GRAFP	9066391	9060770	9060771	9060772	9060773	9060774	9060775	9060776	9060777	
Intake grid with filter (to be used in combination with straight inlet flange) GRAFG	9066401	9060774	9060775	9060776	9060777	9060778	9060779	9060780	9060781	
Silencer Plenum BXS	-	-	9069081	9069082	9069083	9069084	9069085	9069086	9069087	
Hotel box kit for concealed installation for horizontal model (frontal return and air supply) CHK	-	-	9066783	9066784	9066785	9066786	9066787	-	-	

Dimensions

YFCN/YFCN-ECM 130 to 940 (with casing)



VC, VCB and HC models

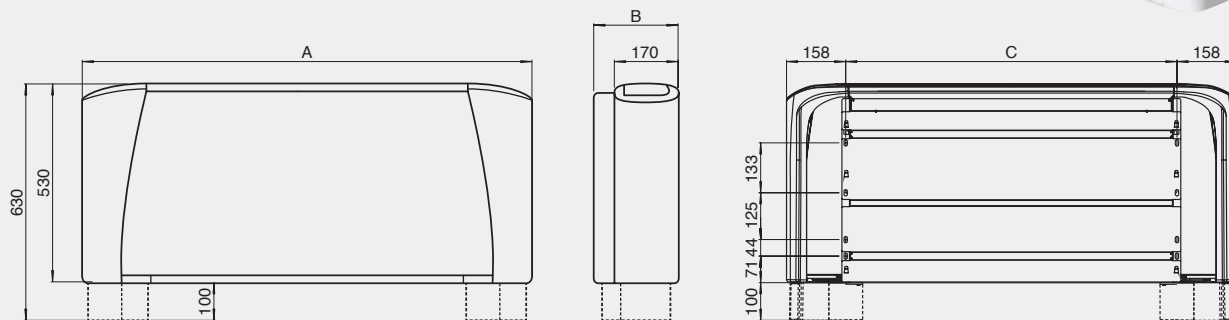

All dimensions in mm. Drawings not a scale.

Model	130 / 140	230 / 240	330 / 340	430 / 440	530 / 540	630 / 640	730 / 740	830 / 840	930 / 940
A	670	770	985	985	1 200	1 200	1 415	1 415	1 415
B	225	225	225	225	225	225	225	255	255
C	354	454	669	669	884	884	1 099	1 099	1 099

YFCN/YFCN-ECM 130 to 940 (without casing)

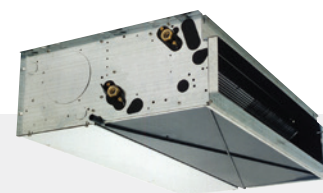

CD models

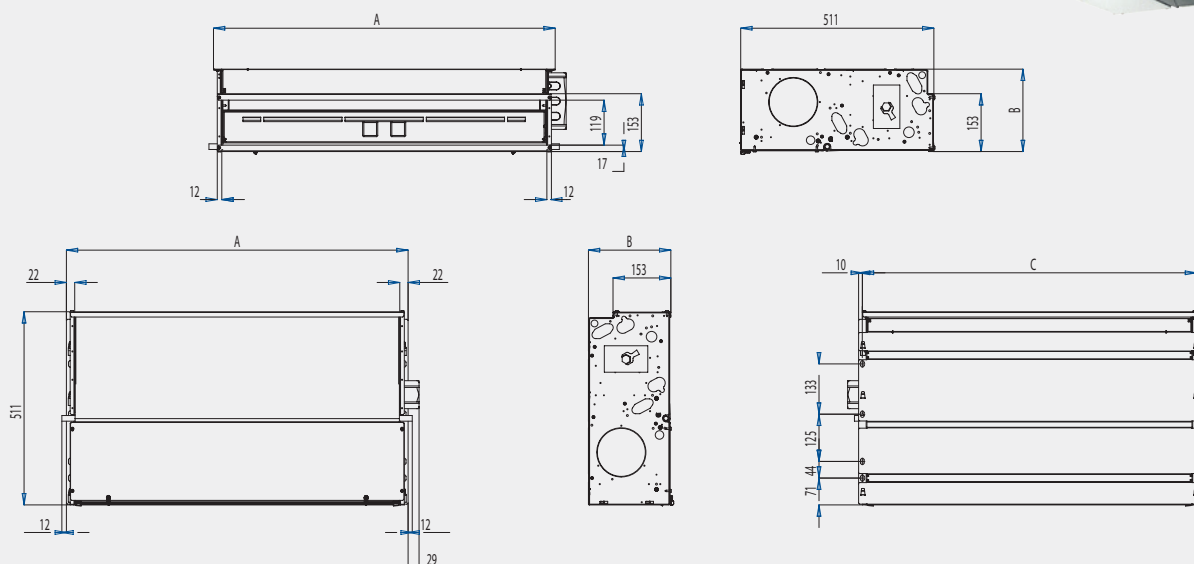

All dimensions in mm. Drawings not a scale.

Model	130 / 140	230 / 240	330 / 340	430 / 440	530 / 540	630 / 640	730 / 740	830 / 840	930 / 940
A	374	474	689	689	904	904	1 119	1 119	1 119
B	218	218	218	218	218	218	218	248	248
C	354	454	669	669	884	884	1 099	1 099	1 099

YFTS-ECM

Fan Coil Unit inverter with tangential fan

2 pipe system

A complete range from 0.4 kW to 3.81 kW



The YFTS-ECM fan coil unit combines a reduced dimension with a modern aesthetic, while maintaining great performances in terms of sound and consumption.

YFTS-ECM includes the VC version for wall installation and the CDV version for concealed installation; the VC version combines a reduced dimension, until 126 mm depth only, with a modern aesthetic that perfectly suits with any kind of furnishing, while maintaining great performances in terms of sound and consumption.



Selection software

Wired controls



T9000 Series

Red Dot Product Design Award Winner 2020

- Touch Screen Display
- 2 or 4 pipes FCU
- 3-speed motors or ECM motors
- 2-wiring/3-wiring on/off valves or proportional valves
- Relay designed for 100,000 switching cycles
- Modbus or BACnet protocols



T7600 Series

- LCD Screen Display
- 2 or 4 pipes FCU
- On/off or proportional
- 3-speed motors or ECM motors
- Modbus RTU



Infrared control



TUC03+ Terminal unit controller

BacNET and N2 Metasys network compatible



Features

- Modern casing, improved aesthetics, suitable for any modern indoor ambient
- Full range for all needs: 5 sizes suitable for vertical mounting with or without casing
- Low noise operation
- 3 fan speeds (possible choice between 6 fan speeds)
- EC motor with inverter at low energy consumption
- Breeze frame kit and recessed box for wall concealed installation in option
- Factory fitted 2 or 3 way valve (on/off) and controller packages
- Fan assembly made of plastic
- Tangential fan with anti-vibration fins
- 2 available versions in all range:
 - VC = Vertical Discharge with Casing
 - CDV = Concealed unit without Casing
- EUROVENT Certified

YFTS-ECM Fan Coil Unit inverter with tangential fan

0.4 kW to 3.81 kW



ECM the Energy Saving Technology

Brushless motor with inverter managed by dedicated controls. It permits to maintain extremely low electrical absorption and a continuous modulation of the air flow.

Technical features

YFTS-ECM model (2 pipes)		10	20	30	40	50	
Total cooling capacity [kW]	(1)	max	0.92	1.62	2.61	3.36	3.81
		med	0.66	1.15	1.91	2.50	2.92
		min	0.40	0.67	0.92	1.14	1.44
Sensible cooling capacity [kW]	(1)	max	0.75	1.28	1.99	1.99	2.83
		med	0.52	0.88	1.41	1.41	2.10
		min	0.30	0.50	0.67	0.67	1.04
Pressure drop in cooling [kPa]	(1)	max	14.7	7.4	18.6	39.1	16.9
		med	9.1	4.9	11.5	23.7	11.2
		min	4.9	3.1	4.5	7.3	4.6
Heating capacity [kW]	(2)	max	1.10	1.81	2.90	3.62	4.20
		med	0.78	1.32	2.10	2.58	3.00
		min	0.55	0.97	1.52	1.79	2.19
Pressure drop in heating [kPa]	(2)	max	16.2	7.3	18.2	36.2	16.2
		med	9.6	5.0	11.0	20.6	9.7
		min	6.1	3.7	7.1	11.7	6.4
Air flow [m³/h]		max	205	305	470	575	645
		med	130	205	315	380	430
		min	75	125	190	220	255
Fan [W]		max	10.3	14.0	21.6	25.4	29.5
		med	5.2	6.3	8.6	9.9	11.4
		min	3.2	3.7	4.1	4.7	5.3
Sound power level [dB(A)]		max	50	52	53	55	55
		med	40	42	43	45	46
		min	31	30	32	33	34
Sound pressure level [dB(A)]	(3)	max	41	43	44	46	46
		med	31	33	34	36	37
		min	22	21	23	24	25
Power supply [V-ph-Hz]		230 / 1 / 50 + E					
Dimensions *	Height	mm	580	580	580	580	580
	Width	mm	640	840	1040	1240	1440
	Depth	mm	126	126	126	126	126
Weight *		kg	10.1	13.2	16.4	19.6	23.0

(1) Room temperature 27°C d.b., 19°C w.b. - Water temperature 7/12 °C.

(2) Room temperature 20°C - Water temperature 45/40 °C.

(3) The sound pressure levels are 9 dB(A) lower than the sound power levels and apply to the reverberant field of a 100 m³ room and a reverberation time of 0.5 sec.

* Dimensions refer to the units with casing. Feet not included.



Manufacturer reserves the rights to change specifications without prior notice.

YFTS-ECM

Fan Coil Unit inverter with tangential fan

Compatibility tables



Model YFTS-ECM	10	20	30	40	50
Accessories (supplied loose)					
Feet PAP-F			9071074		
Breeze frame kit for wall concealed installation CBF-A	-	9071162	-	-	-
Breeze frame kit for wall concealed installation CBF-B	-	-	9071163	-	-
Breeze frame kit for wall concealed installation CBF-C	-	-	-	9071164	-
Recessed box for wall concealed installation IBF 2	-	9071152	-	-	-
Recessed box for wall concealed installation IBF 3	-	-	9071153	-	-
Recessed box for wall concealed installation IBF 4	-	-	-	9071154	-
2 way valve ON-OFF 230 V with electric motor and mounting kit			9071090		
3 way water valve ON-OFF 230 V and mounting kit			9071091		
Controls for YFTS-ECM					
CB-E control fitted on the unit (1)			9071060		
CB-Touch control fitted on the unit (2)			9071061		
Automatic speed control with electronic thermostat and S/W switch - JWC-AU (to be used with UPM-AU and UP-AU only) (3) (4)			9066632K		
Automatic remote control with electronic thermostat, S/W switch and liquid crystal display T-MB (to be used with UPM-AU and UP-AU only) (3) (4)			9066331E		
UP-ECO power unit for CB-E control			9071064		
UP-Touch power unit for CB-Touch, JWC-AU and T-MB controls			9071065		
WM-503-AC-ECM Continuous fan speed control with electronic thermostat, summer/winter switch and LCD display			9066686		
Power unit UPM-AU for JWC-AU and T-MB remote controls, fitted on the unit			9066641		
Power unit UP-AU for JWC-AU and T-MB remote controls, not fitted on the unit			9066640		
UP-503-AC-EC Power unit for WM-503-AC-EC control			9066687		
KIT 503-KNX Mounting kit for power unit UP-503-AC-EC			9071076		
T2 sensor (to be used as Change-over or minimum temperature Sensor)			9025310		

- (1) The control must always be connected with UP-ECO power unit (separately delivered).
 (2) The control must always be connected with UP-Touch power unit (separately delivered).
 (3) Can be used with valves and/or low temperature cut-out.
 (4) Can be used with Change Over.



CB-E control fitted on the unit

- Set the unit ON or stand-by
- Set the fan speed
- Fan OFF and valve closing when the SETPOINT selected with the centralized thermostat (programmable thermostat) is reached.
- Button lock controller and regulation of LED brightness



CB-Touch control fitted on the unit

- Set the unit ON or stand-by
- Operation mode (Summer/Winter/Ventilation)
- Set the fan speed / automatic fan speed
- Possibility to use the T1 sensor as return air probe (mounted on the power unit)
- Possibility to use the T3 sensor as low temperature cut-out thermostat (mounted on the power unit)
- It allows to use the T2 sensor as Change-over (mounted on the power unit).
- Night mode, Alarm messages, OFFSET regulation
- Button lock controller and regulation of LED brightness

Dimensions

YFTS-ECM 130 to 940 (with casing)

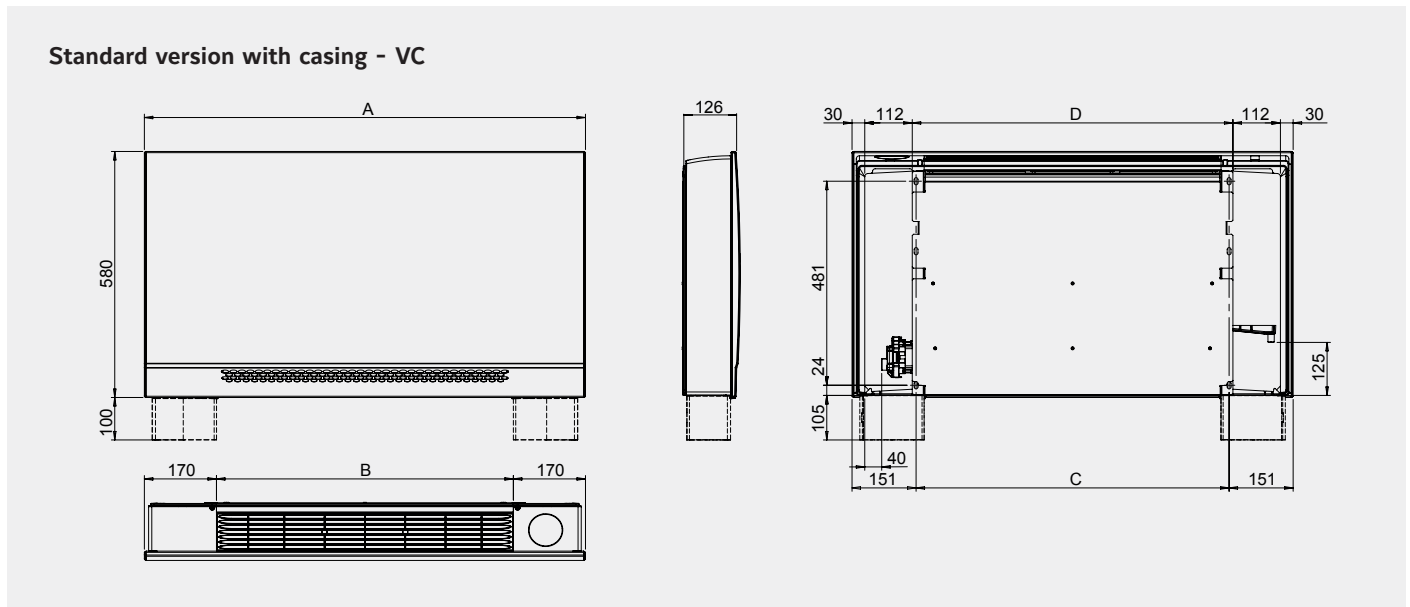

All dimensions in mm. Drawings not a scale.

YFTS-ECM 130 to 940 (without casing)

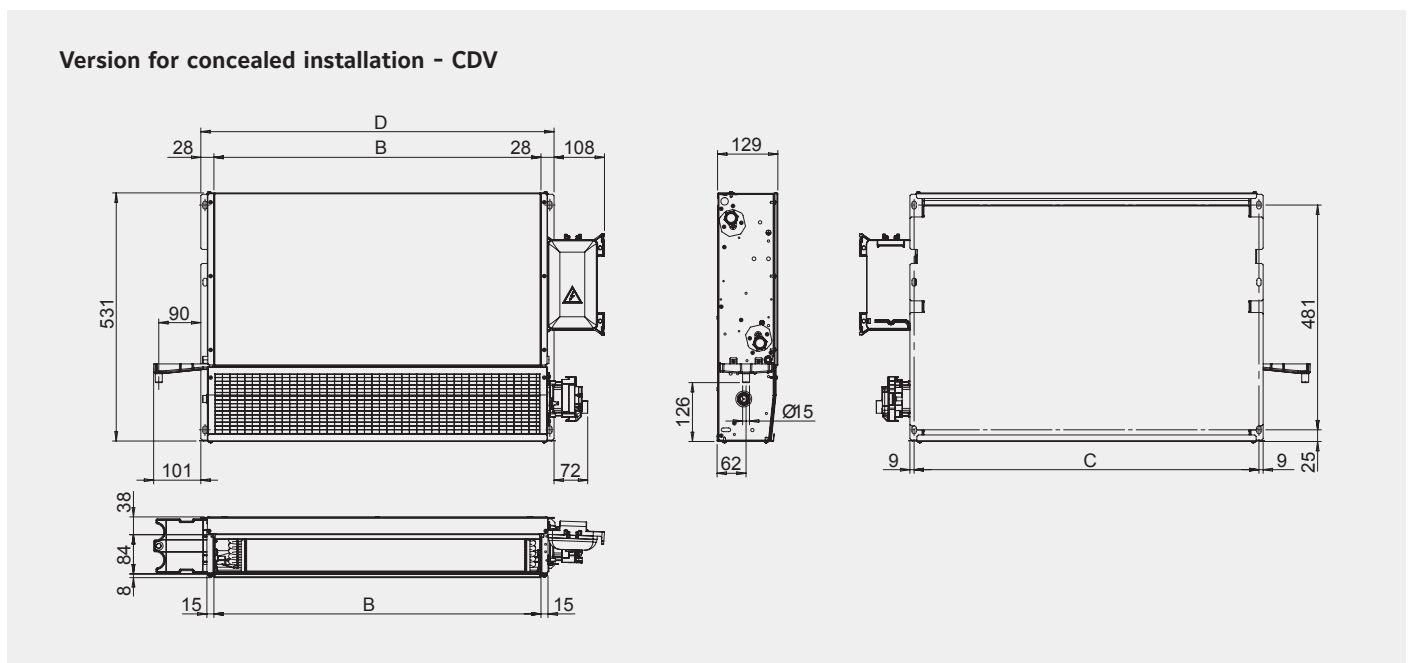

All dimensions in mm. Drawings not a scale.

Model	10	20	30	40	50
A	640	840	1040	1240	1440
B	300	500	700	900	1100
C	338	538	738	938	1138
D	356	556	756	956	1156

LASER and LOW BODY Fan Coil Units

2 and 4 pipe system

A complete range from 0.6 kW up to 9.7 kW



TUC03+ Terminal unit controller
BacNET and N2 Metasys network compatible



**CSL00 (Built in)
CSR00 (Wall mounted)**
Fan speed selector



**CEL00 (Built in)
CER00 (Wall mounted)**
Thermostat with manual fan speed and automatic change over



**CEL20 (Built in)
CER20 (Wall mounted)**
Thermostat with auto. fan speed and automatic change over



**CML00 (Built in)
CMR00 (Wall mounted)**
Thermostat with manual fan speed and S/W change over

**CEL30 (Built in)
CER30 (Wall mounted)**
Thermostat with auto. fan speed and automatic change over for modulating valve

LASER fan coil units are simple and elegant, discreet in their design. High standards of quality and reliability, combined with a wide range of accessories ensure a total solution for all comfort cooling and heating requirements.

LOW BODY units are part of the LASER Fan Coils Units family. The reduced height cabinet makes them the ideal solution for new or replacement applications where dimensional limitations apply.

Features

- 6 speed fan
- Cabinet factory fitted
- Valve factory fitted
- Electrical heater factory fitted
- Thermal or modulating valve
- Service valve
- Option front air intake (LASER)
- Optional plenum (LASER)
- ECM inverter option available
- Option for district cooling coil
- EUROVENT Certified



Selection software

LASER and LOW BODY Fan Coil Units

0.6 kW to 9.7 kW



Technical features

Model		LASER: YLV, YLV-AF, YLH, YLH-AF, YLIV, YLIV-AF, YLIH, YLIH-AF										
Sizes		110	112	114	216	218	220	222	224	226	328	
Total cooling capacity [kW]	(1)	max	1.11	1.59	2.14	3.30	3.50	4.44	5.07	6.43	7.25	9.73
		med	0.95	1.31	1.88	2.67	2.99	3.68	4.39	5.75	6.67	8.75
		min	0.76	1.07	1.57	2.20	2.46	2.94	3.84	4.62	5.50	6.36
Sensible cooling capacity [kW]	(1)	max	0.93	1.25	1.90	2.46	3.06	3.53	4.42	5.06	5.70	8.04
		med	0.78	0.99	1.64	1.95	2.51	2.84	3.74	4.44	5.18	7.15
		min	0.61	0.79	1.33	1.56	2.00	2.20	3.20	3.45	4.15	5.03
Water flow in cooling [l/h]	(1)	max	191	274	368	568	602	764	873	1107	1248	1675
		med	164	225	324	460	515	633	756	990	1148	1506
		min	131	184	270	379	423	506	661	795	947	1095
Pressure drop in cooling [kPa]	(1)	max	3.4	7.1	5.8	14.8	13.6	24.1	28.4	18.8	21.0	74.6
		med	2.8	5.0	4.6	12.5	9.8	17.4	21.8	15.5	18.1	61.5
		min	2.0	3.4	3.3	8.5	6.7	11.6	17.2	10.5	12.8	30.8
Heating capacity 2 pipes [kW]	(2)	max	1.37	1.83	2.60	3.46	4.17	4.80	6.04	6.60	7.86	10.54
		med	1.13	1.46	2.07	2.90	3.51	3.89	5.11	5.84	7.17	9.64
		min	0.87	1.14	1.70	2.31	2.83	3.01	4.41	4.58	5.76	6.73
Water flow in heating 2 pipes [l/h]	(2)	max	236	315	448	596	718	826	1040	1136	1353	1814
		med	194	251	356	499	604	669	879	1004	1233	1658
		min	150	196	292	397	487	518	759	788	991	1158
Pressure drop in heating 2 pipes [kPa]	(2)	max	4.9	6.0	6.5	14.7	16.0	23.4	27.7	18.9	25.3	82.4
		med	4.6	6.0	5.1	10.5	11.7	16.3	21.1	15.3	21.6	67.7
		min	3.0	4.1	4.0	6.9	8.1	10.8	16.4	10.3	14.9	29.7
Heating capacity 4 pipes [kW]	(3)	max	0.91	1.31	1.93	2.79	3.20	4.33	4.92	6.16	6.30	8.00
		med	0.83	1.13	1.85	2.40	2.81	3.67	4.33	5.55	5.98	7.43
		min	0.71	0.95	1.51	2.06	2.38	2.99	3.84	4.55	5.03	5.83
Water flow in heating 4 pipes [l/h]	(3)	max	78	113	166	240	275	373	423	530	542	688
		med	71	97	159	207	242	316	373	478	515	639
		min	61	82	130	177	205	257	330	391	433	501
Pressure drop in heating 4 pipes [kPa]	(3)	max	1.3	3.4	6.7	14.7	7.1	10.3	11.7	33.0	31.7	46.5
		med	1.1	2.6	5.8	10.5	5.7	7.7	9.5	23.0	28.9	40.6
		min	0.9	1.8	5.2	9.4	4.0	5.4	7.7	16.3	21.4	24.7
Air flow [m3/h]		max	243	317	432	606	754	961	1115	1307	1507	2010
		med	181	253	352	488	616	776	928	1106	1318	1687
		min	136	185	279	377	486	594	742	779	986	1107
Sound power level [dB(A)]		max	48	50	54	53	55	54	60	60	63	67
		med	42	45	49	47	50	48	56	55	60	63
		min	36	38	42	40	43	40	50	47	53	52
Sound pressure level [dB(A)]	(4)	max	39	41	45	44	46	45	51	51	54	58
		med	33	36	40	38	41	39	47	46	51	54
		min	27	29	33	31	34	31	40	38	44	43
Power supply [V-ph-Hz]		230 / 1 / 50 + E										
Power input [W]	max	46	48	57	61	76	90	117	140	162	213	
Absorbed current [A]	max	0.21	0.21	0.25	0.27	0.33	0.39	0.52	0.64	0.71	0,95	
Dimensions	Height	mm	538	538	538	538	538	614	614	614	614	614
	Width	mm	648	773	898	1023	1148	1273	1273	1523	1523	1773
	Depth	mm	224	224	224	224	224	254	254	254	254	254

(1) Room temperature 27°C d.b., 19°C w.b. - Water temperature 7/12 °C

(2) Room temperature 20°C - Water inlet temperature: 45/40°C

(3) Room temperature 20°C - Water inlet temperature: 65/55°C.

(4) Sound pressure level in a 100 m³ room, at 1.5 m distance and riverberating time of 0.3 s. max = speed 2, med = speed 3, min = speed 5 when using selection software



Manufacturer reserves the rights to change specifications without prior notice.

LASER and LOW BODY Fan Coil Units

0.6 kW to 9.7 kW



Technical features

Model		LOW BODY: YLVR, YLIVR					
Sizes		110	112	114	216	218	
Total cooling capacity [kW]	(1)	max	0.98	1.21	1.87	2.74	3.23
		med	0.81	1.02	1.61	2.35	2.81
		min	0.64	0.80	1.37	1.84	2.37
Sensible cooling capacity [kW]	(1)	max	0.90	1.09	1.62	2.32	2.71
		med	0.73	0.92	1.39	1.97	2.34
		min	0.56	0.71	1.15	1.54	1.95
Water flow in cooling [l/h]	(1)	max	166	207	318	519	614
		med	139	175	274	442	531
		min	109	137	233	346	446
Pressure drop in cooling [kPa]	(1)	max	2.5	3.5	8.4	7.1	10.2
		med	1.9	2.6	6.5	5.4	7.9
		min	1.3	1.8	5.0	3.6	5.9
Heating capacity 2 pipes [kW]	(2)	max	1.18	1.53	2.22	3.16	3.78
		med	0.95	1.29	1.9	2.67	3.25
		min	0.76	1.02	1.58	2.18	2.71
Water flow in heating 2 pipes [l/h]	(2)	max	204	265	384	595	717
		med	163	224	328	501	612
		min	130	176	273	405	506
Pressure drop in heating 2 pipes [kPa]	(2)	max	2.5	4.2	9.3	7.3	11.8
		med	1.7	3.2	7.1	5.4	8.9
		min	1.2	2.1	5.2	3.7	6.4
Heating capacity 4 pipes [kW]	(3)	max	1.12	1.79	1.87	2.54	3.83
		med	0.93	1.54	1.65	2.22	3.37
		min	0.77	1.25	1.42	1.89	2.88
Water flow in heating 4 pipes [l/h]	(3)	max	98	157	165	224	338
		med	81	135	145	196	297
		min	68	109	125	167	254
Pressure drop in heating 4 pipes [kPa]	(3)	max	1.8	4.8	6.5	11.8	5.9
		med	1.3	3.7	5.2	9.4	4.7
		min	1.0	2.5	4.0	7.1	3.6
Air flow [m ³ /h]		max	243	317	432	606	754
		med	181	253	352	488	616
		min	136	185	279	377	486
Sound power level [dB(A)]		max	47	50	53	51	55
		med	41	44	49	45	50
		min	34	38	42	39	43
Sound pressure level [dB(A)]	(4)	max	37	40	44	42	46
		med	31	35	39	36	41
		min	25	29	33	29	34
Power supply [V-ph-Hz]		230 / 1 / 50 + E					
Power input [W]	max	46	48	57	61	76	
Absorbed current [A]	max	0.21	0.21	0.25	0.27	0.33	
Dimensions	Height	mm	430	430	430	430	430
	Width	mm	648	773	898	1023	1148
	Depth	mm	254	254	254	254	224

(1) Room temperature 27°C d.b., 19°C w.b. - Water temperature 7/12 °C

(2) Room temperature 20°C - Water inlet temperature: 45/40°C

(3) Room temperature 20°C - Water inlet temperature: 65/55°C.

 (4) Sound pressure level in a 100 m³ room, at 1.5 m distance and riverberating time of 0.3 s. max = speed 2, med = speed 3, min = speed 5 when using selection software

Manufacturer reserves the rights to change specifications without prior notice.

Options / Accessories

Compatibility table / Codes

Model		LASER										LOW BODY				
Sizes		110	112	114	216	218	220	222	224	226	328	110	112	114	216	218
With Cabinet																
YLV-YLH	2/3/4 rows	•	•	•	•	•	•	•	•	•						
YLV-YLH/AF Front air intake	2/3/4 rows	•	•	•	•	•	•	•	•	•						
YLVR	2/3 rows										•	•	•	•	•	
Without Cabinet																
YLIV-YLIH	2/3/4 rows	•	•	•	•	•	•	•	•	•						
YLIV-YLIH/AF Front air intake	2/3/4 rows	•	•	•	•	•	•	•	•	•						
YLIVR	2/3 rows										•	•	•	•	•	
Options (Factory fitted)																
Coil and heaters																
1 row heating	BA1	•	•	•	•	•	•	•	•	•	•	•	•	•	•	•
Kit electrical heater (with relay and safety switch)	KREL	•	•	•	•	•	•	•	•	•	•	•	•	•	•	•
Built in thermostat																
Fan speed selector	CSL00									•						
Thermostat with manual fan speed and S/W change over	CML00									•						
Thermostat with manual fan speed, dead band, automatic change over	CEL00									•						
Thermostat with automatic fan speed, dead band, automatic change over	CEL20									•						
Thermostat with automatic fan speed, dead band, automatic change over for modulating valve	CEL30									•						
Parallel connection																
For ON/OFF valve one/FCU	CBL20									•						
For modulating valve one/FCU	CBL30									•						
3 way valve factory fitted																
For 2 pipe systems ON/OFF	J3A2 (2p)									•						
For 4 pipe systems ON/OFF	J3A2 (4p)									•						
3 way modulating valve factory fitted																
For 2 pipe systems Modulating	J3AM (2p)									•						
For 4 pipe systems Modulating	J3AM (4p)									•						
Shut off valves factory fitted																
For 2 pipe systems	DT (2p)									•						
For 4 pipe systems	DT (4p)									•						
Condensate pump	PC									•						
WS sensor change over for CEL/CER	WS									•						
Minimum temperature thermostat	TM									•						
Accessories (Supplied loose)																
Remote controllers and thermostat (wall mounted)																
Fan speed selector	CSR00									•						
Thermostat with manual fan speed and S/W change over	CMR00									•						
Thermostat with manual fan speed, dead band, automatic change over	CER00									•						
Thermostat with automatic fan speed, dead band, automatic change over	CER20									•						
Thermostat with automatic fan speed, dead band, automatic change over for modulating valve	CER30									•						
Feet and panel (1)																
Set of painted feet	CP1	•	•	•	•	•	•	•	•	•						
Set of painted feet + frontal socle	ZL1	•	•	•	•	•	•	•	•	•						
Vertical painted back panel	PPV1	•	•	•	•	•	•	•	•	•						
Horizontal painted back panel	PPH1	•	•	•	•	•	•	•	•	•						
Plenums and air intake (1)																
Air intake plenum	PA	•	•	•	•	•	•	•	•	•						
Air intake plenum with collars	PAS	•	•	•	•	•	•	•	•	•						
90° air intake plenum	PA90	•	•	•	•	•	•	•	•	•						
Air intake duct fitting	RCA	•	•	•	•	•	•	•	•	•						
Air delivery plenum with collars	PM	•	•	•	•	•	•	•	•	•						
90° air delivery plenum	PM90	•	•	•	•	•	•	•	•	•						

(1) for check compatibility with the models of FCU see compatibility table

Dimensions and Weights

YLV and YLH

- V = vertical
- H = horizontal

YLV-AF and YLH-AF

- AF = front air intake
- V = vertical
- H = horizontal

YLV-R

- R= low body
- V= vertical

LASER: YLV - YLV/AF

VERTICAL

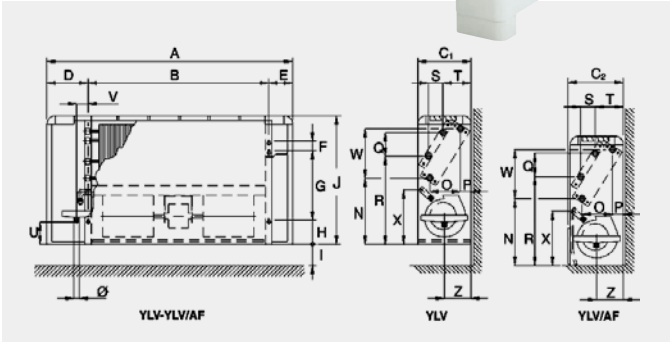

LASER: YLH - YLH/AF

HORIZONTAL

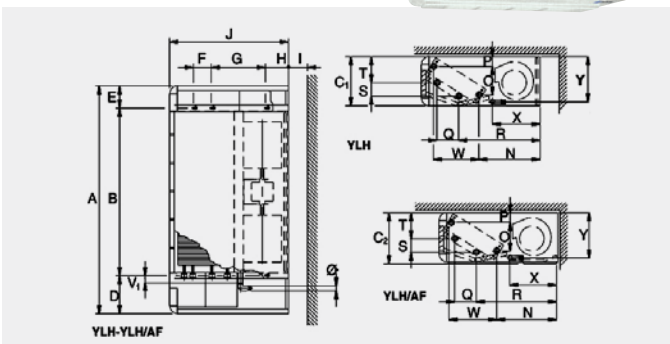

LOW BODY: YLV-R

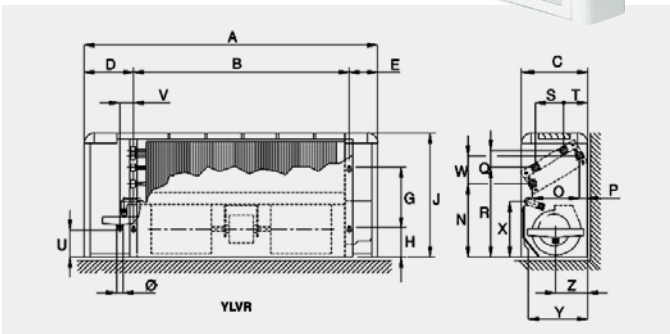

Dim	110	112	114	216	218	220	222	224	226	328
A	648	773	898	1023	1148	1273	1273	1523	1523	1773
B	374	499	624	749	874	999	999	1249	1249	1499
C1	224	224	224	224	224	254	254	254	254	254
C2	233	233	233	233	233	263	263	263	263	263
D	174	174	174	174	174	174	174	174	174	174
E	100	100	100	100	100	100	100	100	100	100
F	40	40	40	40	40	40	40	40	40	40
G	280	280	280	280	280	356	356	356	356	356
H	101	101	101	101	101	101	101	101	101	101
I	85	85	85	85	85	85	85	85	85	85
J	538	538	538	538	538	614	614	614	614	614
N	266	266	266	266	266	299	299	299	299	299
O	113	113	113	113	113	138	138	138	138	138
P	48	48	48	48	48	53	53	53	53	53
Q	87	87	87	87	87	87	87	87	87	87
R	355	355	355	355	355	409	409	409	409	409
S	50	50	50	50	50	50	50	50	50	50
T	117	117	117	117	117	135	135	135	135	135
U	90	90	90	90	90	116	116	116	116	116
V	47	47	47	47	47	47	47	47	47	47
V 1	28	28	28	28	28	28	28	28	28	28
W	195	195	195	195	195	238	238	238	238	238
X	219	219	219	219	219	252	252	252	252	252
Y	205	205	205	205	205	235	235	235	235	235
Z	109	109	109	109	109	122	122	122	122	122
Ø	20	20	20	20	20	20	20	20	20	20
kg1	18	20	23	28	31	41	44	52	52	58
kg2	19	21	24	30	32	43	46	54	54	61

Notes: 1=YLV / YLH - 2=YLV/AF / YLH/AF (All dimensions in mm)

Dim	110	112	114	216	218
A	648	773	898	1023	1148
B	374	499	624	749	874
C	254	254	254	254	254
D	174	174	174	174	174
E	100	100	100	100	100
G	170	170	170	170	170
H	101	101	101	101	101
J	430	430	430	430	430
N	245	245	245	245	245
O	154	154	154	154	154
P	31	31	31	31	31
Q	47	47	47	47	47
R	304	304	304	304	304
S	88	88	88	88	88
T	87	87	87	87	87
U	65	65	65	65	65
V	47	47	47	47	47
W	84	84	84	84	84
X	214	214	214	214	214
Z	109	109	109	109	109
Ø	20	20	20	20	20
kg	15	17	22	23	26

(All dimensions in mm)

Dimensions & Weights

YLIV and YLIH

- V = vertical
- H = horizontal
- I = without cabinet

YLIV-AF and YLIH-AF

- AF = front air intake
- V = vertical
- H = horizontal
- I = without cabinet

YLIVR

- R = low body
- V = vertical
- I = without cabinet

LASER: YLIV - YLIV/AF

VERTICAL

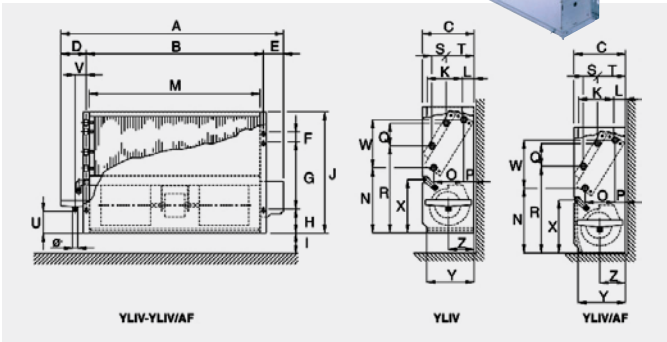
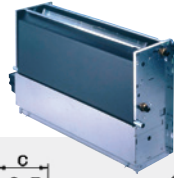

LASER: YLIH - YLIH/AF

HORIZONTAL

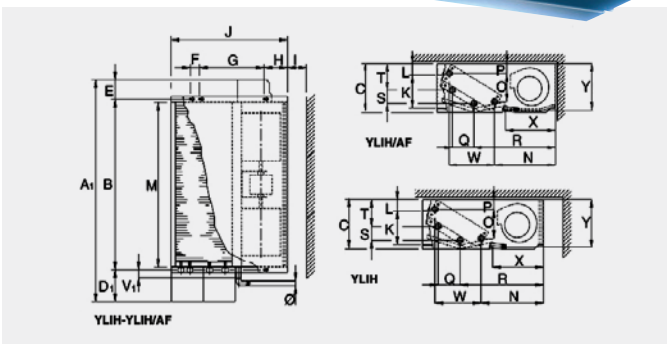

LOW BODY: YLIVR

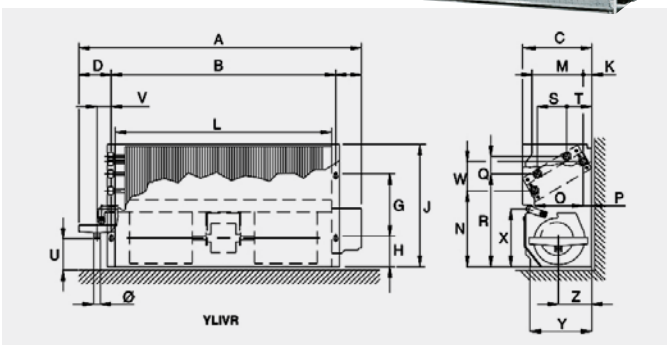

Dim	110	112	114	216	218	220	222	224	226	328
A	555	680	805	930	1055	1180	1180	1430	1430	1680
A1	574	699	824	949	1074	1199	1199	1449	1449	1699
B	374	499	624	749	874	999	999	1249	1249	1499
C	215	215	215	215	215	245	245	245	245	245
D	109	109	109	109	109	109	109	109	109	109
D1	128	128	128	128	128	128	128	128	128	128
E	72	72	72	72	72	72	72	72	72	72
F	40	40	40	40	40	40	40	40	40	40
G	280	280	280	280	280	356	356	356	356	356
H	101	101	101	101	101	101	101	101	101	101
I	85	85	85	85	85	85	85	85	85	85
J	505	505	505	505	505	581	581	581	581	581
K	110	110	110	110	110	125	125	125	125	125
L	55	55	55	55	55	60	60	60	60	60
M	349	474	599	724	849	974	974	1224	1224	1474
N	266	266	266	266	266	299	299	299	299	299
O	113	113	113	113	113	138	138	138	138	138
P	48	48	48	48	48	53	53	53	53	53
Q	87	87	87	87	87	87	87	87	87	87
R	355	355	355	355	355	409	409	409	409	409
S	50	50	50	50	50	50	50	50	50	50
T	117	117	117	117	117	135	135	135	135	135
U	90	90	90	90	90	116	116	116	116	116
V	47	47	47	47	47	47	47	47	47	47
V1	28	28	28	28	28	28	28	28	28	28
W	195	195	195	195	195	238	238	238	238	238
X	219	219	219	219	219	252	252	252	252	252
Y	200	200	200	200	200	230	230	230	230	230
Z	109	109	109	109	109	122	122	122	122	122
Ø	20	20	20	20	20	20	20	20	20	20
kg	10	13	16	19	22	29	31	38	38	42

(All dimensions in mm)

Dim	110	112	114	216	218
A	555	680	805	930	1055
B	374	499	624	749	874
C	230	230	230	230	230
D	108	108	108	108	108
E	73	73	73	73	73
G	170	170	170	170	170
H	101	101	101	101	101
J	395	395	395	395	395
K	61	61	61	61	61
L	349	474	599	724	849
M	127	127	127	127	127
N	245	245	245	245	245
O	154	154	154	154	154
P	31	31	31	31	31
Q	47	47	47	47	47
R	304	304	304	304	304
S	88	88	88	88	88
T	87	87	87	87	87
U	65	65	65	65	65
V	47	47	47	47	47
W	84	84	84	84	84
X	214	214	214	214	214
Y	201	201	201	201	201
Z	109	109	109	109	109
Ø	20	20	20	20	20
kg	9	11	14	16	19

(All dimensions in mm)

LASER and LOW BODY Fan Coil Units

Compatibility tables



**CSL00 (Built in)
CSR00 (Wall mounted)**
Fan speed selector



**CEL00 (Built in)
CER00 (Wall mounted)**
Thermostat with manual fan speed and automatic change over



**CML00 (Built in)
CMR00 (Wall mounted)**
Thermostat with manual fan speed and S/W change over

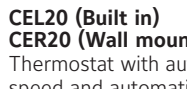

**CEL20 (Built in)
CER20 (Wall mounted)**
Thermostat with auto. fan speed and automatic change over

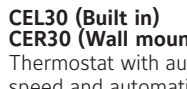

**CEL30 (Built in)
CER30 (Wall mounted)**
Thermostat with auto. fan speed and automatic change over for modulating valve

Features CEL/CER

- Dead band for change over 5°C or 2°C (factory set 2°C)
- Manual fan speeds or automatic (models 20 and 30)
- Thermostated fan control or continuous fan running
- Option water sensor WS for change over on coil (for 2 pipes)
- Led indicated status summer, winter or dead band
- Temperature setting for 7 to 30°C (comfort 20–25°C)
- Plastic pins for limiting temperature range
- Input for window contact
- Input for Economy/ occupancy mode
- Output for remote alarm
- Filter alarm 600 or 1200 running hours (factory set 1200 hours)
- With electrical heater post ventilation
- With Air sensor in the air intake destratification function (CEL only)

Compatibility table Thermostats / Valves / Heaters / Parallel connection / Water sensor / Minimum temperature thermostat

Factory fitted thermostat (built in)		Valves for 2 pipes		Valves for 4 pipes		Heaters	Parallel connection		Water sensor	Min. Temp. Thermostat
		J3A2 (2p)	J3AM (2p)	J3A2 (4p)	J3AM (4p)		ON/OFF	Modulating		
CSL00	Fan speed selector						•			•
CML00	Thermostat with manual fan speed and S/W change over	•		•			•			•
CEL00	Thermostat with manual fan speed, dead band, automatic change over	•		•		•	•		•	•
CEL20	Thermostat with automatic fan speed, dead band, automatic change over	•		•		•	•		•	•
CEL30	Thermostat with automatic fan speed, dead band, automatic change over for modulating valve		•		•			•	•	•

Remote controllers and thermostats (wall mounted)										
CSR00	Fan speed selector						•			•
CMR00	Thermostat with manual fan speed and S/W change over	•		•			•			•
CER00	Thermostat with manual fan speed, dead band, automatic change over	•		•		•	•		•	•
CER20	Thermostat with automatic fan speed, dead band, automatic change over	•		•		•	•		•	•
CER30	Thermostat with automatic fan speed, dead band, automatic change over for modulating valve		•		•			•	•	•

• Compatible Not compatible

LASER and LOW BODY Fan Coil Units

Compatibility tables



Compatibility Options / Accessories / Models

Code		Designation	STANDARD								LOW BODY	
			LASER				CONCEALED				YLVR	YLIVR
Code	Designation	YLV	YLH	YLV-AF	YLH-AF	YLIV	YLH	YLIV-AF	YLH-AF	YLVR	YLIVR	
Coils and heaters**												
BA1**	Additional 1 row heating	•	•	•	•	•	•	•	•	•	•	
KREL**	Kit electrical heater with safety thermostat and relay	•	•	•	•	•	•	•	•			
Factory fitted thermostat (built in)												
CSL00	Fan speed selector (built in)	•				•				•	•	
CML00	Thermostat with manual fan speed and S/W change over	•				•				•	•	
CEL00	Thermostat with manual fan speed, dead band, automatic change over	Compatible with electrical heaters								•	•	
CEL20	Thermostat with automatic fan speed, dead band, automatic change over	Compatible with electrical heaters								•	•	
CEL30	Thermostat with automatic fan speed, dead band, automatic change over for modulating valves	•		•		•		•		•	•	
CBL20	Parallel connection for ON/OFF valve	•	•	•	•	•	•	•	•	•	•	
CBL30	Parallel connection for modulating valve	•	•	•	•	•	•	•	•	•	•	
Remote controllers and thermostats (wall mounted)												
CSR00	Fan speed selector (wall mounted)	•	•	•	•	•	•	•	•	•	•	
CMR00	Thermostat with manual fan speed and S/W change over	•	•	•	•	•	•	•	•	•	•	
CER00	Thermostat with manual fan speed, dead band, automatic change over	Compatible with electrical heaters								•	•	
CER20	Thermostat with automatic fan speed, dead band, automatic change over	Compatible with electrical heaters								•	•	
CER30	Thermostat with automatic fan speed, dead band, automatic change over for modulating valves	•	•	•	•	•	•	•	•	•	•	
Valves / Condensate pump / Water sensor / Minimum temperature thermostat (Factory fitted)												
J3A2 (2p)	3-way 4-ports on/off valves for 2-pipe systems	•	•	•	•	•	•	•	•	•	•	
J3A2 (4p)	3-way 4-ports on/off valves for 4-pipe systems	•	•	•	•	•	•	•	•	•	•	
J3AM (2p)	3-way 4-ports modulating valves for 2-pipe systems	•	•	•	•	•	•	•	•	•	•	
J3AM (4p)	3-way 4-ports modulating valves for 4-pipe systems	•	•	•	•	•	•	•	•	•	•	
DT (2p)	Shut-off valves for 2-pipe systems (in addition to J3A2/J3AM valves)	•	•	•	•	•	•	•	•	•	•	
DT (4p)	Shut-off valves for 4-pipe systems (in addition to J3A2/J3AM valves)	•	•	•	•	•	•	•	•	•	•	
PC	Condensate pump	•	•	•	•	•	•	•	•	•	•	
WS	Water sensor	Compatible with CEL/CER										
TM	Minimum temperature thermostat	•	•	•	•	•	•	•	•	•	•	
Feet and panels												
CP1	Set of painted feet	•				•						
ZL1	Set of feet + frontal socle	•										
PPV1	Vertical painted back panel	•		•						•		
PPH1	Horizontal painted back panel		•		•							
External air intake												
PA	Air intake plenum							•				
PAS	Air intake plenum collars							•				
PA90	90° air intake plenum							•				
RCA	Air intake duct fitting							•				
PM	Air delivery plenum with collars					•	•	•	•		•	
PM90	90° air delivery plenum					•	•	•	•		•	

- Compatible
- Compatible with conditions
- Not compatible

** Maximum of rows is indicated in the documentation, the maximum number of rows includes the heating row or electrical heater.

LASER ECM and LOW BODY ECM Inverter Fan Coil Units

0.6 kW to 9.2 kW



ECM the Energy Saving Technology

Brushless motor with inverter managed by dedicated controls. It permits to maintain extremely low electrical absorption and a continuous modulation of the air flow.

Technical features

Model		LASER ECM							LOW BODY ECM		
Sizes	(*)	512	514	516	520	522	524	528	512	514	516
Total cooling capacity [kW]	max ...v	1.98	2.56	3.81	5.05	5.81	7.47	9.18	1.56	2.37	3.40
	med ...v	1.43	1.81	2.53	3.86	4.42	5.64	6.94	1.18	1.78	2.34
	min ...v	0.74	0.93	1.51	2.72	3.05	4.07	4.89	0.61	1.29	1.53
Sensible cooling capacity [kW]	max	1.65	2.12	3.14	3.79	4.32	6.09	7.51	1.42	2.09	2.93
	med	1.16	1.48	2.01	2.78	3.16	4.42	5.50	1.04	1.54	1.96
	min	0.54	0.78	1.21	1.92	2.11	3.13	3.74	0.53	1.09	1.25
Water flow in cooling [l/h]	max	341	441	656	869	1000	1286	1580	265	404	644
	med	246	312	435	664	761	971	1194	200	304	440
	min	127	160	260	468	525	701	842	104	220	286
Pressure drop in cooling [kPa]	max	9.6	9.2	14.6	16.9	36.2	16.8	31.3	8.2	12.6	10.3
	med	5.4	4.8	8.5	10.6	22.0	10.0	18.5	5.1	7.8	5.4
	min	1.7	1.6	3.9	5.6	11.1	5.5	9.7	1.8	4.5	2.6
Heating capacity 2 pipes [kW]	max	2.05	3.04	4.40	5.76	6.53	8.43	10.4	2.07	2.85	4.00
	med	1.47	2.18	3.05	4.44	4.84	6.22	7.67	1.50	2.09	2.66
	min	0.78	1.15	1.87	3.11	3.37	4.50	5.38	0.8	1.49	1.77
Water flow in heating 2 pipes [l/h]	max	353	523	757	991	1124	1451	1790	358	495	763
	med	253	375	525	757	833	1071	1320	260	362	499
	min	134	198	322	535	580	775	926	138	258	325
Pressure drop in heating 2 pipes [kPa]	max	10.8	10.3	17.3	21.8	40.0	17.2	32.2	9.7	14.4	11.2
	med	6.0	5.5	8.6	13.0	23.5	9.8	18.0	5.6	8.4	5.3
	min	2.0	2.0	4.2	6.6	11.5	5.3	9.0	1.9	4.7	2.6
Heating capacity 4 pipes [kW]	max	1.84	2.39	3.20	5.00	5.55	6.46	7.90	2.19	2.29	3.06
	med	1.37	1.76	2.40	4.12	4.35	5.19	6.30	1.66	1.78	2.22
	min	0.87	1.09	1.77	3.22	3.29	4.09	4.94	0.97	1.36	1.60
Water flow in heating 4 pipes [l/h]	max	158	206	275	430	478	556	680	194	201	271
	med	118	151	207	355	374	447	542	146	157	196
	min	75	94	152	277	283	352	425	84	119	141
Pressure drop in heating 4 pipes [kPa]	max	4.7	9.3	15.6	23.3	21.5	36.0	46.2	6.9	9.2	16.5
	med	2.8	5.4	11.0	15.9	14.0	24.2	30.7	4.2	6.0	9.3
	min	1.2	2.4	5.6	9.8	7.7	15.4	19.5	1.0	3.7	5.3
Air flow [m ³ /h]	max	456	574	792	1082	1304	1567	1995	437	608	833
	med	298	373	489	757	904	1080	1370	284	400	486
	min	138	170	287	504	568	715	876	129	259	290
Sound power level [dB(A)]	max	55	59	60	57	62	63	69	55	53	56
	med	44	48	47	48	51	53	59	42	42	44
	min	29	29	33	37	39	43	48	30	33	30
Sound pressure level [dB(A)]	max	46	50	51	48	53	54	60	46	44	46
	med	35	39	38	37	42	44	50	33	32	34
	min	21	21	24	26	30	34	39	20	24	20
Power supply [V-ph-Hz]		230 / 1 / 50 + E									
Power input [W]	max	31	54	42	46	76	89	168	35	60	38
Dimensions	Height mm	623	623	623	699	699	699	699	395	395	395
	Width mm	773	898	1023	1273	1273	1523	1773	680	805	930
	Depth mm	224	224	224	254	254	254	254	230	230	230

(1) Room temperature 27°C d.b., 19°C w.b. - Water temperature 7/12 °C
 (2) Room temperature 20°C - Water inlet temperature: 45/40°C
 (3) Room temperature 20°C - Water inlet temperature: 65/55°C.
 (4) Sound pressure level in a 100 m³ room, at 1.5 m distance and riverberating time of 0.3 s.
 (*) 512 - 514 (3v-6v-9v) | 516 (2v-5v-10v) | 520 - 522 - 524 - 528 (3v-6v-10v)



Manufacturer reserves the rights to change specifications without prior notice.

LASER ECM and LOW BODY ECM Inverter Fan Coil Units

Compatibility tables



Compatibility Options / Accessories / Models

		STANDARD								LOW BODY-ECM	
		LASER-ECM				CONCEALED-ECM				YLVR	YLIVR
Code	Designation	YLV	YLH	YLV-AF	YLH-AF	YLIV	YLIV-AF	YLIV-AF	YLIV-AF		
Coils and heaters**											
BA1**	Additional 1 row heating	•	•	•	•	•	•	•	•	•	•
KREL**	Kit electrical heater with safety thermostat and relay	•	•	•	•	•	•	•	•		
Factory fitted thermostat (built in)											
EDCL	Microprocessor control for ECM units	•		•		•		•		•	•
OBV11-ODC711	Omnibus control for ECM units + Analogue Plus console	•		•		•		•		•	•
OBV11-ODC211	Omnibus control for ECM units + Display console	•		•		•		•		•	•
Remote controllers and thermostats (wall mounted)											
EDCR	Microprocessor control for ECM units, for wall installation	•	•	•	•	•	•	•	•	•	•
OBV10+ODC716	Omnibus control for ECM units + Remote Analogue Plus console	•	•	•	•	•	•	•	•	•	•
OBV10+ODC216	Omnibus control for ECM units + Remote Display console	•	•	•	•	•	•	•	•	•	•
Valves / Condensate pump / Water sensor / Minimum temperature thermostat (Factory fitted)											
J3A2 (2p)	3-way 4-ports on/off valves for 2-pipe systems	•	•	•	•	•	•	•	•	•	•
J3A2 (4p)	3-way 4-ports on/off valves for 4-pipe systems	•	•	•	•	•	•	•	•	•	•
J3AM (2p)	3-way 4-ports modulating valves for 2-pipe systems	•	•	•	•	•	•	•	•	•	•
J3AM (4p)	3-way 4-ports modulating valves for 4-pipe systems	•	•	•	•	•	•	•	•	•	•
DT (2p)	Shut-off valves for 2-pipe systems (in addition to J3A2/J3AM valves)	•	•	•	•	•	•	•	•	•	•
DT (4p)	Shut-off valves for 4-pipe systems (in addition to J3A2/J3AM valves)	•	•	•	•	•	•	•	•	•	•
PC	Condensate pump	•	•	•	•	•	•	•	•	•	•
WS	Water sensor	Compatible with all the above listed controllers									
Feet and panels											
CP1	Set of painted feet	•				•					
ZL1	Set of feet + frontal socle	•									
PPV1	Vertical painted back panel	•		•						•	
PPH1	Horizontal painted back panel		•		•						
External air intake											
PA	Air intake plenum							•			
PAS	Air intake plenum collars							•			
PA90	90° air intake plenum							•			
RCA	Air intake duct fitting							•			
PM	Air delivery plenum with collars					•	•	•	•		•
PM90	90° air delivery plenum					•	•	•	•		•

- Compatible
- Compatible with conditions
- Not compatible

** Maximum of rows is indicated in the documentation, the maximum number of rows includes the heating row or electrical heater.

YHPL/YHPL-ECM High Static Pressure Blower

YHPL / YHPL-ECM 030-840 · 2 and 4 pipe system
A complete range from 0.8 kW to 10,92 kW



ECM Inverter version
also available!



YHPL and YHPL-ECM offers a complete range with the ability to satisfy all air conditioning need in working environments such as offices, shops, restaurants and hotel rooms, for ducted installations up to 80 Pa External Static Pressure.

These new ranges replace our earlier YHP-O series, offering lower noise levels, a strengthened structure and wider operating envelope.

The YHPL series comes in 7 sizes from 205 to 1425 m³/h with option of 3 or 4 row cooling coils, offering up to 8.62 kW of cooling, with facility to add 1 or 2 row heating coil and offer a 4 pipe system.

ECM version comes in 6 sizes and covers the airflow capacity of 110 to 1941 m³/h and up to 10.92 kW of cooling.

Wired controls



WM-3V
Remote three speeds controller

JWC-T
WC-3V + Electronic thermostat and Summer/Winter switch

JWC-AU
Automatic JWC-T



T9000 Series

- **Red Dot Product Design Award Winner 2020**
- Touch Screen Display
- 2 or 4 pipes FCU
- 3-speed motors or ECM motors
- 2-wiring/3-wiring on/off valves or proportional valves
- Relay designed for 100,000 switching cycles
- Modbus or BACnet protocols



T7600 Series

- LCD Screen Display
- 2 or 4 pipes FCU
- On/off or proportional
- 3-speed motors or ECM motors
- Modbus RTU



TUC03+ Terminal unit controller
BacNET and N2 Metasys network compatible



Features

- 9 sizes
- From 0.8 to 10.92 kW cooling
- Horizontal or vertical version
- Low noise operation
- 5 speed fan
- A wide range of thermostats and accessories
- Available with left or right connections

Optionally the main valve, auxiliary valve (4 tubes), controller and wiring can be assembled from factory, for an easy installation in a centralized management system.



Selection software

YHPL High Static Pressure Blower

1.4 kW to 8.6 kW



Technical features

YHPL model (2 pipes)		130	140	230	240	330	340	430	440	530	540	630	640	730	740
Total cooling capacity [kW]	(1) max	2	2.22	3.6	4.28	4.72	5.36	5.47	5.94	5.72	6.22	7.11	7.82	7.7	8.62
	med	1.88	2.07	3.4	4.01	4.42	4.99	4.97	5.36	5.04	5.44	6.62	7.25	7.11	7.92
	min	1.43	1.54	2.57	2.93	2.68	2.89	3.85	4.1	3.3	3.48	3.99	4.23	5.58	6.1
Sensible cooling capacity [kW] (1)	max	1.44	1.57	2.7	3.04	3.55	3.84	4.22	4.46	4.19	4.52	5.36	5.72	5.89	6.38
	med	1.35	1.46	2.53	2.84	3.3	3.55	3.77	3.97	3.64	3.89	4.94	5.26	5.37	5.8
	min	1.01	1.07	1.85	2.03	1.9	2.0	2.82	2.95	2.31	2.43	2.83	2.96	4.06	4.34
Pressure drop in cooling [kPa] (1)	max	20.00	11.00	19.60	31.30	17.70	36.10	23.20	15.60	33.10	18.10	18.70	15.60	21.70	18.70
	med	17.00	9.70	17.70	27.90	15.70	31.70	19.40	12.90	26.30	14.20	16.40	13.60	18.80	16.10
	min	11.00	5.60	10.60	15.80	6.30	11.80	12.20	7.90	12.20	6.30	6.60	5.10	12.20	10.10
Heating capacity [kW] (2)	max	2.11	2.23	3.98	4.34	5.22	5.42	6.27	6.55	6.25	6.54	7.58	8.34	8.49	9.42
	med	1.96	2.07	3.7	4.02	4.82	4.99	5.56	5.77	5.36	5.57	6.96	7.63	7.73	8.52
	min	1.43	1.49	2.67	2.85	2.71	2.76	4.1	4.22	3.33	3.41	3.94	4.17	5.82	6.3
Pressure drop in heating [kPa] (2)	max	18.00	10.50	18.30	26.20	16.60	28.90	23.00	14.50	30.40	16.70	16.50	15.00	20.20	18.60
	med	16.00	9.20	16.10	22.80	14.30	24.90	18.60	11.50	23.00	12.50	14.20	12.70	17.10	15.60
	min	9.00	5.10	8.90	12.30	5.10	8.60	10.70	6.60	9.70	5.20	5.10	4.30	10.30	9.00
Air flow [m³/h]	max	315	315	625	625	790	790	980	980	970	970	1240	1240	1425	1425
	med	290	290	575	575	720	720	850	850	810	810	1120	1120	1270	1270
	min	205	205	395	395	380	380	600	600	475	475	580	580	905	905
Available static pressure [Pa]	max	58	58	58	58	60	60	65	65	70	70	60	60	63	63
	med	50	50	50	50	50	50	50	50	50	50	50	50	50	50
	min	25	25	26	26	14	14	23	23	18	18	15	15	26	26
Fan [W]	max	51	51	94	94	110	110	148	148	140	140	145	145	186	186
	med	45	45	87	87	96	96	122	122	110	110	125	125	177	177
	min	27	27	59	59	50	50	88	88	65	65	69	69	155	155
Sound power outlet [dB(A)]	max	43	43	49	49	51	51	55	55	53	53	52	52	56	56
	med	42	42	47	47	48	48	52	52	48	48	50	50	53	53
	min	34	34	38	38	36	36	44	44	37	37	38	38	46	46
Sound pressure outlet [dB(A)] (4)	max	34	34	40	40	42	42	46	46	44	44	43	43	47	47
	med	33	33	38	38	39	39	43	43	39	39	41	41	44	44
	min	25	25	29	29	27	27	35	35	28	28	29	29	37	37
Power supply [V-ph-Hz]		230 / 1 / 50 + E													
Power input [W]	max	60	60	115	115	132	132	185	185	185	185	175	175	260	260
Absorbed current [A]	max	0.30	0.30	0.50	0.50	0.60	0.60	0.90	0.90	0.90	0.90	0.80	0.80	1.20	1.20
Dimensions	Height mm	248	248	248	248	248	248	248	248	248	248	248	248	248	248
	Width mm	689	689	904	904	1119	1119	1119	1119	1334	1134	1549	1549	1549	1549
	Depth mm	511	511	511	511	511	511	511	511	511	511	511	511	511	511

YHPL model (4 pipes)		130+1	140+1	230+1	240+1	330+1	340+1	430+1	440+1	530+1	540+1	630+1	640+1	730+1	740+1
Total cooling capacity [kW]	(1) max	2	2.22	3.6	4.28	4.72	5.36	5.47	5.94	5.78	6.22	7.11	7.82	7.7	8.62
	med	1.88	2.07	3.4	4.01	4.42	4.99	4.97	5.36	5.1	5.44	6.62	7.25	7.11	7.92
	min	1.43	1.54	2.57	2.93	2.68	2.89	3.85	4.1	3.32	3.48	3.99	4.23	5.58	6.1
Sensible cooling capacity [kW] (1)	max	1.44	1.57	2.7	3.04	3.55	3.84	4.22	4.46	4.23	4.52	5.36	5.72	5.89	6.38
	med	1.35	1.46	2.53	2.84	3.3	3.55	3.77	3.97	3.67	3.89	4.94	5.26	5.37	5.8
	min	1.01	1.07	1.85	2.03	1.9	2	2.82	2.95	2.33	2.43	2.83	2.96	4.06	4.34
Pressure drop in cooling [kPa] (1)	max	19.5	11	19.6	31.3	17.7	36.1	23.2	15.6	33.7	18.1	18.7	15.6	21.7	18.7
	med	17.4	9.7	17.7	27.9	15.7	31.7	19.4	12.9	26.7	14.2	16.4	13.6	18.8	16.1
	min	10.5	5.6	10.6	15.8	6.3	11.8	12.2	7.9	12.3	6.3	6.6	5.1	12.2	10.1
Heating capacity [kW] (3)	max	1.76	1.76	3.02	3.02	3.91	3.91	4.49	4.49	4.63	4.63	5.8	5.8	6.35	6.35
	med	1.66	1.66	2.85	2.85	3.68	3.68	4.1	4.1	4.11	4.11	5.44	5.44	5.9	5.9
	min	1.3	1.3	2.22	2.22	2.38	2.38	3.26	3.26	2.85	2.85	3.48	3.48	4.72	4.72
Pressure drop in heating [kPa] (3)	max	7.5	7.5	4.8	4.8	7.5	7.5	9.6	9.6	9.1	9.1	15.3	15.3	18.1	18.1
	med	6.8	6.8	4.3	4.3	6.7	6.7	8.2	8.2	7.4	7.4	13.7	13.7	15.8	15.8
	min	4.4	4.4	2.8	2.8	3.1	3.1	5.4	5.4	3.8	3.8	6.1	6.1	10.6	10.6
Air flow [m³/h]	max	315	315	625	625	790	790	980	980	970	970	1240	1240	1425	1425
	med	290	290	575	575	720	720	850	850	810	810	1120	1120	1270	1270
	min	205	205	395	395	380	380	600	600	475	475	580	580	905	905

The table below is based on Eurovent conditions and may vary according to specific requirements.

(1) Room temperature 27°C d.b., 19°C w.b. - Water temperature 7/12 °C.

(2) Room temperature 20°C - Water temperature 45/40 °C.

(3) Room temperature 20°C - Water temperature 65/55 °C.

(4) The sound pressure levels are 9 dB(A) lower than the sound power levels and apply to the reverberant field of a 100 m³ room and a reverberation time of 0.5 sec.



Manufacturer reserves the rights to change specifications without prior notice.

YHPL-ECM Inverter High Static Pressure Blower

0.8 kW to 10,92 kW

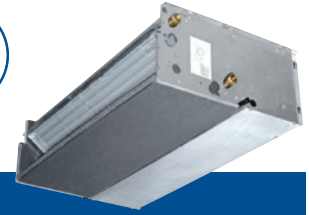

ECM the Energy Saving Technology

Brushless motor with inverter managed by dedicated controls. It permits to maintain extremely low electrical absorption and a continuous modulation of the air flow.

Technical features

YHPL-ECM model (2 pipes)			030	040	130	140	230	240	430	440	730	740	830	840
Total cooling capacity [kW]	(1)	max	1,65	1,95	2.23	2.48	3.55	4.25	5.43	5.91	7.67	8.47	10	10,6
		med	1,39	1,55	1.97	2.17	3.21	3.79	4.94	5.34	6.81	7.46	8,6	9,25
		min	0,75	0,8	1.64	1.77	2.72	3.14	3.84	4.09	5.66	6.12	6,75	7,2
Sensible cooling capacity [kW]	(1)	max	1,3	1,45	1.63	1.78	2.68	3.04	4.21	4.45	5.86	6.33	7,8	8,2
		med	1	1,15	1.42	1.54	2.38	2.68	3.77	3.97	5.11	5.48	6,5	7,1
		min	0,55	0,6	1.17	1.25	1.99	2.20	2.83	2.95	4.15	4.40	5,05	5,5
Pressure drop in cooling [kPa]	(1)	max	9,2	15,4	23	13	19	31	23	15	21	18	39	40
		med	6,7	10,8	19	10	16	25	19	13	17	14	29	30
		min	3,5	3,5	13	7	12	18	12	8	12	10	19	20
Heating capacity [kW]	(2)	max	1,9	2	2.37	2.52	4.00	4.37	6.27	6.55	8.24	9.35	10,7	11,5
		med	1,5	1,65	2.05	2.17	3.51	3.80	5.56	5.77	7.09	7.96	9,25	10
		min	0,8	0,8	1.65	1.73	2.88	3.08	4.07	4.19	5.69	6.26	7	8
Pressure drop in heating [kPa]	(2)	max	8	12,3	22	13	18	27	23	14	19	18	43	39
		med	5,5	8,1	17	10	15	21	19	12	15	14	34	30
		min	1,7	2,6	12	7	10	14	11	6	10	9	25	20
Air flow [m³/h]		max	290	290	360	360	630	630	980	980	1410	1410	1923	1923
		med	225	225	305	305	540	540	850	850	1175	1175	1638	1638
		min	110	110	240	240	430	430	595	595	900	900	1238	1238
Available static pressure [Pa]		max	75	75	68	68	70	70	66	66	72	72	70	70
		med	50	50	50	50	50	50	50	50	50	50	50	50
		min	10	10	32	32	34	34	24	24	30	30	28	28
Fan [W]		max	37	37	39	39	64	64	98	98	155	155	246	246
		med	21	21	29	29	43	43	67	67	100	100	160	160
		min	7	7	18	18	26	26	30	30	52	52	84	84
Sound power outlet [dB(A)]		max	48	48	48	48	49	49	55	55	57	57	59	59
		med	43	43	44	44	47	47	52	52	54	54	56	56
		min	29	29	38	38	42	42	44	44	47	47	49	49
Sound pressure outlet [dB(A)]	(4)	max	39	39	39	39	40	40	46	46	48	48	50	50
		med	34	34	35	35	38	38	43	43	45	45	47	47
		min	20	20	29	29	33	33	35	35	38	38	40	40
Power supply [V-ph-Hz]		230 / 1 / 50 + E												
Power input [W]	max	55.5	55.5	52	52	134	134	131	131	303	303	420	420	
Absorbed current [A]	max	0.5	0.5	0.4	0.4	1.1	1.1	1.1	1.1	1.4	1.4	2.6	2.6	
Dimensions	Height mm	248	248	248	248	248	248	248	248	248	248	248	248	
	Width mm	474	474	689	689	904	904	1119	1119	1549	1549	1764	1764	
	Depth mm	511	511	511	511	511	511	511	511	511	511	511	511	

YHPL-ECM model (4 pipes)			030+1	040+1	130+1	140+1	230+1	240+1	430+1	440+1	730+1	740+1	830+1	840+1
Total cooling capacity [kW]	(1)	max	1,65	1,76	2.23	2.48	3.55	4.25	5.35	5.91	7.67	8.47	10	10,92
		med	1,39	1,48	1.97	2.17	3.21	3.79	4.88	5.34	6.81	7.46	8,6	9,75
		min	0,75	0,87	1.64	1.77	2.72	3.14	3.84	4.09	5.66	6.12	6,75	7,95
Sensible cooling capacity [kW]	(1)	max	1,3	1,23	1.63	1.78	2.67	3.04	4.13	4.45	5.86	6.33	7,8	7,88
		med	1	1,04	1.42	1.54	2.38	2.68	3.71	3.97	5.11	5.48	6,5	6,92
		min	0,55	0,59	1.17	1.25	1.98	2.20	2.83	2.95	4.15	4.40	5,05	5,57
Pressure drop in cooling [kPa]	(1)	max	6,5	10,7	23	13	19	31	22	15	21	18	39	25,5
		med	5,5	7,7	19	10	16	25	18	13	17	14	29	20,6
		min	3,5	2,1	13	7	12	18	12	8	12	10	19	14,2
Heating capacity [kW]	(3)	max	1,29	1,29	1.92	1.92	3.03	3.03	4.22	4.22	6.31	6.31	7,8	7,8
		med	1,07	1,07	1.72	1.72	2.74	2.74	3.87	3.87	5.60	5.60	7	7
		min	0,56	0,56	1.46	1.46	2.36	2.36	3.09	3.09	4.70	4.70	6	6
Pressure drop in heating [kPa]	(3)	max	3,2	3,2	9	9	5	5	9	9	18	18	29	29
		med	2,4	2,4	7	7	4	4	7	7	14	14	27	27
		min	1,1	1,1	5	5	3	3	5	5	11	11	20	20
Air flow [m³/h]		max	290	290	360	360	630	630	960	960	1410	1410	1923	1941
		med	225	225	305	305	540	540	835	835	1175	1175	1638	1640
		min	110	110	240	240	430	430	595	595	900	900	1238	1238

The table below is based on Eurovent conditions and may vary according to specific requirements.

(1) Room temperature 27°C d.b., 19°C w.b. - Water temperature 7/12 °C.

(2) Room temperature 20°C - Water temperature 45/40 °C.

(3) Room temperature 20°C - Water temperature 65/55 °C.

(4) The sound pressure levels are 9 dB(A) lower than the sound power levels and apply to the reverberant field of a 100 m³ room and a reverberation time of 0.5 sec.



Manufacturer reserves the rights to change specifications without prior notice.

YHPL and YHPL-ECM High Static Pressure Blower

Compatibility tables



Compatibility table / Codes

Model YHPL	-	130-140	230-240	330-340	430-440	530-540	630-640	730-740	-
Model YHPL-ECM	030-040	130-140	230-240	-	430-440	-	-	730-740	830-840

Accessories (factory fitted)

Valves (220V On/Off)

Kit 3 way valve mounted - primary battery YHPL 0-1 VPBM-C G1-5 V.220	9066561					-			
Kit 3 way valve mounted - primary battery YHPL 2-3-4-5 VBPM-C G6-9 V.220	-			9060471				-	
Kit 3 way valve mounted - primary battery YHPL 6-7 VBPM-C SL6-7 V.220			-				9069208		-
Kit 3 way valve mounted - primary battery YHPL 8 VBPM-C SL8 V.220				-					9069213W
Kit 3 way valve mounted - YHPL 0-7 additional battery VBAM-C G1-9 V.220				9060472					-
Kit 3 way valve mounted - YHPL 8 additional battery VBAM-C SL8 V.220					-				9069214W
Kit 2 way valve mounted YHPL 0-1 V2M-C G1-5 V.220	9060476					-			
Kit 2 way valve mounted YHPL 2-3-4-5 V2M-C G6-9 V.220	-			9060477				-	
Kit 2 way valve mounted YHPL 6-7 V2M-C SL6-7 V.220			-				9069203		-
Kit 2 way valve mounted YHPL 8 V2M-C SL8 V.220				-					9069203W
Kit 2 way valve mounted YHPL 0-7 additional battery V2M-C G1-5 V.220				9060476					-
Kit 2 way valve mounted YHPL 8 additional battery V2M-C G6-9 V.220				-					9060477W
3 way simplified valve kit mounted YHPL 0-1 VSPM-C G1-5 V.220	9066571					-			
3 way simplified valve kit mounted YHPL 2-3-4-5 VSPM-C G6-9 V.220	-			9060484				-	
3 way simplified valve kit mounted YHPL 6-7 VSPM-C SL6-7 V.220			-				9069211		-
3 way simplified valve kit mounted YHPL 8 VSPM-C SL8 V.220				-					9069215W
3 way simplified valve kit mounted YHPL 0-7 additional battery VSAM-C 1-9 V.220				9060483					-
3 way simplified valve kit mounted YHPL 8 additional battery VSAM-C SL8 V.220				-					9069216W

Accessories (supplied loose)

Valves (220V On/Off)

Kit 3 way valve not mounted - primary battery YHPL 0-1 VBPS-C G1-5 V.220	9066560					-			
Kit 3 way valve not mounted - primary battery YHPL 2-3-4-5 VBPS-C G-69 V.220	-			9060474				-	
Kit 3 way valve not mounted - primary battery YHPL 6-7 VBPS-C SL6-7 V.220			-				9069206		-
Kit 3 way valve mounted - primary battery YHPL 8 VBPS-C SL8 V.220									9069217W
Kit 3 way valve not mounted - YHPL 0-7 additional battery VBAS-C G1-9 V.220				9060475					-
Kit 3 way valve not mounted - YHPL 8 additional battery VBAS-C SL8 V.220				-					9069218W
Kit 2 way valve not mounted YHPL 0-1 V2S-C G1-5 V.220	9060478					-			
Kit 2 way valve not mounted YHPL 2-3-4-5 V2S-C G6-9 V.220	-			9060479				-	
Kit 2 way valve not mounted YHPL 6-7 V2S-C SL6-7 V.220			-				9069201		-
Kit 2 way valve not mounted YHPL 8 V2S-C SL8 V.220				-					9069201W
Kit 2 way valve not mounted YHPL 0-7 additional battery V2S-C G1-5 V.220				9060478					-
Kit 2 way valve not mounted YHPL 8 additional battery V2S-C G6-9 V.220				-					9060479W
3 way simplified valve kit not mounted YHPL size 0-1 VSPS-C G1-5 V.220	9066570					-			
3 way simplified valve kit not mounted YHPL 2-3-4-5 VSPS-C G6-9 V.220	-			9060481				-	
3 way simplified valve kit not mounted YHPL 6-7 VSPS-C SL6-7 V.220			-				9069210		-
3 way simplified valve kit not mounted YHPL 8 VSPS-C SL8 V.220				-					9069219W
3 way simplified valve kit not mounted YHPL 0-7 additional battery VSAS-C 1-9 V.220				9060480					-
3 way simplified valve kit not mounted YHPL 8 additional battery VSAS-C SL8 V.220				-					9069220W

YHPL and YHPL-ECM High Static Pressure Blower

Compatibility tables



Compatibility table / Codes

Model YHPL	-	130-140	230-240	330-340	430-440	530-540	630-640	730-740	-
Model YHPL-ECM	030-040	130-140	230-240	-	430-440	-	-	730-740	830-840

Accessories (supplied loose)

Air inlet plenum PMC	9069190	9069191	9069222		9066368	9069195		9069196	9069198
Straight inlet flange	9069370	9069371	9038002		9060724	9069375		9079376	9069378
Inlet flange 90°	9069380	9069381	9038001		9060714	9069385		9069386	9069388
Intake grid 90°	9060760	9060761	9060762		9060763	9068155		9038041	9069158
Intake grid straight	9060764	9060765	9060766		9060767	9069145		9038042	9069148
Straight outlet flange	9069390	9069391	9069232		9066378	9069395		9069396	9069398
Outlet flange 90°	9069400	9069400	9069242		9066388	9069405		9069406	9069408
Intake plenum with spigot	9069180	9069181	9038050		9066468	9069185		9069186	9069188
Outlet grid	9060750	9060751	9060752		9060753	9069415		9038040	9069418
Air inlet silencer plenum	-	9069461	9069462		9069463	9069465		9069466	-
Lateral filter removal	9069530	9069531	9069532		9069533	9069535		9069536	9069538
El. resistance and relays fitted on the unit (1000W) BEL-I G2/10	9066612					-			
El. resistance and relays fitted on the unit (600W) BEL-I G2/06	9066602					-			
El. resistance and relays fitted on the unit (400W) BEL-I G2 / 04	9066592					-			
El. resistance and relays fitted on the unit (1500 W) BEL-I G3-4/15	-	9066613				-			
El. resistance and relays fitted on the unit (900 W) BEL-I G3-4/09	-	9066603				-			
El. resistance and relays fitted on the unit (600 W) BEL-I G3-4/06	-	9066593				-			
El. resistance and relays fitted on the unit (2000 W) BEL-I G5-6/20	-		9066615			-			
El. resistance and relays fitted on the unit (1250 W) BEL-I G5-6/12	-		9066605			-			
El. resistance and relays fitted on the unit (750 W) BEL-I G5-6/07	-		9066595			-			
El. resistance and relays fitted on the unit (2500 W) BEL-I G7-9/25		-			9066617			-	
El. resistance and relays fitted on the unit (1500 W) BEL-I G7-9/15		-			9066607			-	
El. resistance and relays fitted on the unit (1000 W) BEL-I G7-9/10		-			9066597			-	
El. resistance and relays fitted on the unit (2750 W) BEL-I SL5/27			-			9038037		-	
El. resistance and relays fitted on the unit (1650 W) BEL-I SL5/16			-			9038038		-	
El. resistance and relays fitted on the unit (1100 W) BEL-I SL5/11			-			9038039		-	
El. resistance and relays fitted on the unit (3500 W) BEL-I SL6-7/35			-					9038047	-
El. resistance and relays fitted on the unit (2500 W) BEL-I SL6-7/25			-					9038048	-
El. resistance and relays fitted on the unit (1000 W) BEL-I SL6-7/10			-					9038049	-
NC auxiliary condensate tray ACT-NC					6066039				
Mounted condensate pump DRCV - vertical units (auxiliary condensate tray included)					9066297				
Not mounted condensate pump DRCV - vertical units (auxiliary condensate tray included)					9066296				
Fitted condensate pump DRPI-C - concealed units only (auxiliary condensate collection tray included - horizontal installation only)					9066298				
Not mounted condensate pump DRPI-C - only horizontal installation (auxiliary condensate tray included)					9066180				
Condensate drain pipe SCR					6060420				
Front air intake KAF	-	9069361	9069072		9069073	9069365		9069366	-
FLEXI spigot diffuser	9069650	9069651	9069652		9069653	9069655		9069656	9069658
FLEXI air inlet spigot plenum	9069660	9069661	9069662		9069663	9069665		9069666	9069668
DN 125 connection for plenum FLEXI FR-FL 125					6069321				
DN 160 connection for plenum FLEXI FR-FL 160					6069322				
DN 200 connection for plenum FLEXI FR-FL 200					6069323				

YHPL and YHPL-ECM High Static Pressure Blower

Compatibility tables



Compatibility table / Codes

Controls for YHPL models	-	130-140	230-240	330-340	430-440	530-540	630-640	730-740	-
Remote three speed control WM-3V (1) (4)					9066642				
Remote three speed control + electronic thermostat and manual S/W switch JWC-T (2)					9066630K				
Remote three speed control + electronic thermostat and centralized/manual S/W switch JWC-TQR (2) (3)					9066631K				
Automatic speed control with electronic thermostat and S/W switch - JWC-AU (to be used with UPM-AU and UP-AU only) (2) (3)					9066632K				
Automatic remote control with electronic thermostat, S/W switch and liquid crystal display T-MB (2) (3)					9066331E				
Automatic speed control with electronic thermostat to be mounted in the light wall box WM-503-AC-EC (to be used with UP-503-AC-EC only)					9066686				
Electromechanical thermostat T2T (4) (5)					9060174				
Power unit UPM-AU for JWC-AU and T-MB remote controls, fitted on the unit					9066641				
Power unit UP-AU for JWC-AU and T-MB remote controls, not fitted on the unit					9066640				
Power unit UP-503-AC-EC for WM-503-AC-EC remote control only, not fitted on the unit					9066687				
Control accessories for all versions (supplied with separate packaging)									
Low temperature cut-out for controls WM-3V and JWC-T					9053048				
Low temperature cut-out for controls JWC-TQR, WM-503-AC-EC and UP-AU power unit					3021090				
T2 sensor to be used as Change-over for UP-AU power unit					9025310				
Change-over 15-25 for control JWC-TQR					9053049				
Receiver board for control JWC-T and JWC-TQR					9066311				
Controls for YHPL-ECM models	030-040	130-140	230-240	-	430-440	-	-	730-740	830-840
Automatic speed control with electronic thermostat and S/W switch - JWC-AU (to be used with UPM-AU and UP-AU only) (2) (3)					9066632K				
Wall control (to be used with UPM-AU or UP-AU only) TM-B2 SW (2) (3)					9066994ESW				
WM-S-ECM Continuous fan speed control with electronic thermostat, summer/winter switch and LCD display					9066644				
Power unit UPM-AU for JWC-AU and T-MB remote controls, fitted on the unit					9066641				
Power unit UP-AU for JWC-AU and T-MB remote controls, not fitted on the unit					9066640				
Automatic speed control with electronic thermostat to be mounted in the 503 box WM- 503- AC- EC (to be used with UP- 503- AC- EC only)					9066686E				
Power unit for WM- 503- AC- EC remote controls- not fitted on the unit (UP-503- AC- EC)					9066687				
Other type of control options					Contact Johnson Controls				

(1) Not to be used with valves and/or low temperature cut-out. (2) Can be used with valves and/or low temperature cut-out.
 (3) Can be used with Change Over. (4) Not suitable with -E electric heater. (5) Can be used with valve and not to be used with low temperature cut-out.

RFHP-O/RFHPO-ECM

High static pressure blower with centrifugal fan

RFHP-O/RFHPO-ECM 14 - 74+2 · 2 & 4 pipe system

A complete range from 4.1 kW to 30.6 kW



ECM Inverter version
also available!

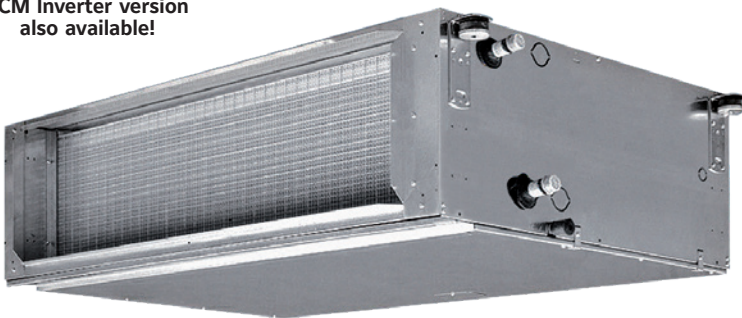

RFHP-O and RFHPO-ECM ranges are designed and built for concealed installations. With small dimensions, they are very silent and offers elevated air flow rates and up to 250 Pa External Static Pressure.

They are suitable for climate control for small and medium commercial and sports environments or for large civil environments and integrate perfectly in regular false ceilings.

The RFHP-O range is available with the combination of either 3 or 4 row coils (sizes 1÷5) with the possibility to add a 1 or 2 row coil (3+1, 4+1, 3+2, 4+2 versions for 4 pipe systems), and 4 or 6 row coils (sizes 6-7) with the possibility to add a 2 row coil (4+2, 6+2 versions for 4 pipe systems).

ECM version comes in 5 sizes and its ability to continuously vary the air flow gives great regulation and control flexibility, at the same time ensuring excellent environmental conditions and extremely low electrical consumption.

Wired controls



WM-3V

Remote three speeds controller

JWC-T

WC-3V + Electronic thermostat and Summer/Winter switch

JWC-AU

Automatic JWC-T



T9000 Series

• Red Dot Product Design Award Winner 2020

- Touch Screen Display
- 2 or 4 pipes FCU
- 3-speed motors or ECM motors
- 2-wiring/3-wiring on/off valves or proportional valves
- Relay designed for 100,000 switching cycles
- Modbus or BACnet protocols



T7600 Series

- LCD Screen Display
- 2 or 4 pipes FCU
- On/off or proportional
- 3-speed motors or ECM motors
- Modbus RTU



TUC03+ Terminal unit controller

BacNET and N2 Metasys network compatible



Features

- 7 sizes
- From 4.0 to 30.63 kW cooling
- Concealed version
- Low noise operation
- 5 speed fan
- A wide range of thermostats and accessories
- Available with left or right connections

Optionally the main valve, auxiliary valve (4 tubes), controller and wiring can be assembled from factory, for an easy installation in a centralized management system.



Selection software

RFHP-O High static pressure blower

4.1 kW to 30.6 kW

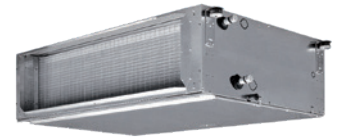

Technical features

RFHP-O model 2 pipes (4 row coil)			14	24	34	44	54 (*)	64 (*)	74 (*)
Total cooling capacity [kW]	(1)	max	5.92	8.15	10.71	13.60	17.76	22.89	30.63
		med	5.21	7.01	9.76	12.40	16.19	18.73	25.33
		min	4.17	4.99	8.71	10.90	14.54	12.42	21.54
Sensible cooling capacity [kW]	(1)	max	5.03	6.62	8.65	10.90	14.37	17.98	24.53
		med	4.26	5.48	7.68	9.70	12.80	14.16	19.46
		min	3.25	3.66	6.67	8.25	11.21	8.88	16.05
Pressure drop in cooling [kPa]	(1)	max	9.6	16.8	23.4	20.9	19.4	22.6	27.6
		med	7.6	12.7	19.8	17.7	16.3	15.3	19.3
		min	5.1	6.9	16.0	13.9	13.3	7.4	14.4
Heating capacity [kW]	(2)	max	7.67	10.10	13.19	16.53	22.93	43.60	61.14
		med	6.44	8.27	11.75	14.92	20.32	33.52	47.85
		min	4.98	5.57	10.20	12.79	17.67	20.86	39.34
Pressure drop in heating [kPa]	(2)	max	11.3	18.3	24.8	21.3	22.8	14.7	18.8
		med	8.2	17.0	23.0	17.7	18.3	9.1	12.1
		min	5.2	6.2	15.6	13.4	14.2	3.9	8.5
Air flow [m³/h]		max	1410	1825	2440	3020	3850	4800	7100
		med	1125	1410	2075	2580	3280	3385	5070
		min	790	840	1710	2070	2740	1880	3925
Fan [W]		max	191	285	470	570	760	1304	2460
		med	154	230	420	490	617	778	1758
		min	115	170	350	390	500	574	1518
Available pressure [Pa]		max	58	61	65	66	70	77	81
		med	52	56	62	63	67	71	75
		min	44	44	57	59	63	63	71
Sound power outlet [dB(A)]		max	49	52	56	57	61	68	72
		med	43	47	53	54	58	62	66
		min	35	35	48	50	54	54	62
Sound pressure outlet [dB(A)]	(4)	max	75	80	70	70	70	150	150
		med	50	50	50	50	50	150	150
		min	25	15	30	35	35	150	150
Power supply [V-ph-Hz]			230 / 1 / 50 + E						
Dimensions	Height	mm	310	310	360	360	435	488	588
	Width	mm	1133	1133	1133	1445	1445	1535	1535
	Depth	mm	698	698	698	853	853	1100	1100
RFHP-O model 4 pipes (with additional coil)			14+1	24+1	34+1	44+1	54+1 (*)	64+2 (*)	74+2 (*)
Total cooling capacity [kW]	(1)	max	5.79	8.03	10.58	13.46	16.73	22.52	30.36
		med	5.11	6.95	9.67	12.34	15.31	18.56	25.25
		min	4.09	4.99	8.61	10.85	13.75	12.33	21.53
Sensible cooling capacity [kW]	(1)	max	4.87	6.49	8.51	10.72	13.56	17.62	24.28
		med	4.16	5.42	7.60	9.61	12.13	14.02	19.39
		min	3.18	3.66	6.58	8.21	10.62	8.81	16.05
Pressure drop in cooling [kPa]	(1)	max	9.20	16.30	22.90	20.50	17.40	22.00	27.10
		med	7.30	12.50	19.40	17.40	14.70	15.00	19.10
		min	4.90	6.90	15.70	13.80	12.00	7.30	14.40
Heating capacity [kW]	(3)	max	5.47	7.16	9.20	12.00	15.28	37.13	51.31
		med	4.87	6.28	8.47	11.07	14.00	29.78	41.88
		min	3.96	4.63	7.62	9.83	12.67	19.81	35.50
Pressure drop in heating [kPa]	(3)	max	21.0	31.9	22.3	39.5	36.3	37.0	46.1
		med	17.0	25.2	19.3	34.1	31.1	24.9	32.0
		min	11.7	14.5	15.9	27.6	26.0	11.9	23.8
Air flow [m³/h]		max	1350	1775	2390	2960	3800	4680	6980
		med	1090	1390	2045	2545	3245	3330	5040
		min	770	840	1680	2055	2700	1860	3920
Fan [W]		max	191	285	470	570	760	1327	2376
		med	154	230	420	490	617	750	1727
		min	115	170	350	390	500	565	1499

(1) Room temperature 27°C d.b., 19°C w.b. - Water temperature 7/12 °C.

(2) Room temperature 20°C - Water temperature 45/40 °C.

(3) Room temperature 20°C - Water temperature 65/55 °C.

(4) The sound pressure levels are 9 dB(A) lower than the sound power levels and apply to the reverberant field of a 100 m³ room and a reverberation time of 0.5 sec.

* Models not covered by EUROVENT certification program.



Manufacturer reserves the rights to change specifications without prior notice.

RFHPO-ECM Inverter high static pressure blower

4.0 kW to 18.2 kW

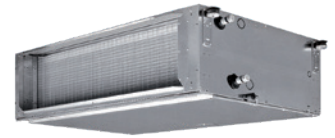

ECM the Energy Saving Technology

Brushless motor with inverter managed by dedicated controls. It permits to maintain extremely low electrical absorption and a continuous modulation of the air flow.

Technical features

RFHPO-ECM model 2 pipes (4 row coil)		14	24	34	44	54 (*)	
Total cooling capacity [kW]	(1)	max	5.61	7.94	10.81	13.99	18.17
		med	5.11	6.86	9.70	12.39	16.70
		min	4.14	5.44	7.87	10.47	13.73
Sensible cooling capacity [kW]	(1)	max	4.72	6.44	8.72	11.23	14.75
		med	4.18	5.36	7.61	9.65	13.26
		min	3.24	4.08	5.93	7.90	10.46
Pressure drop in cooling [kPa]	(1)	max	8.7	15.8	21.6	21.7	21.4
		med	7.2	11.8	17.4	16.9	17.9
		min	4.9	7.7	11.7	12.2	12.3
Heating capacity [kW]	(2)	max	7.76	10.62	13.06	18.08	23.25
		med	6.80	8.64	11.25	15.15	20.51
		min	5.18	6.42	8.64	12.13	15.90
Pressure drop in heating [kPa]	(2)	max	11.1	18.8	21.4	23.9	25.4
		med	8.7	12.9	16.4	17.4	20.3
		min	5.3	7.5	10.1	11.6	12.8
Air flow [m³/h]		max	1310	1780	2390	3080	3920
		med	1100	1360	1950	2440	3320
		min	780	940	1380	1840	2400
Fan [W]		max	144	225	340	530	702
		med	88	110	195	253	383
		min	40	44	80	110	166
Sound power outlet [dB(A)]		max	59	61	64	67	71
		med	52	55	60	62	67
		min	45	45	52	55	58
Sound pressure outlet [dB(A)]	(4)	max	50	52	55	58	62
		med	43	46	51	53	58
		min	36	36	43	46	49
Available pressure [Pa]		max	72	85	75	80	68
		med	50	50	50	50	50
		min	26	24	25	28	26
Power supply [V-ph-Hz]		230 / 1 / 50 + E					
Dimensions	Height mm	310	310	360	360	435	
	Width mm	1133	1133	1133	1445	1445	
	Depth mm	698	698	698	853	853	

RFHPO-ECM model 4 pipes (with additional coil)		14+1	24+1	34+1	44+1	54+1 (*)	
Total cooling capacity [kW]	(1)	max	5.46	7.87	10.70	13.90	18.00
		med	4.94	6.79	9.59	12.27	16.62
		min	4.04	5.36	7.76	10.36	13.66
Sensible cooling capacity [kW]	(1)	max	4.55	6.35	8.61	11.13	14.58
		med	4.01	5.30	7.51	9.53	13.19
		min	3.14	4.01	5.83	7.79	10.39
Pressure drop in cooling [kPa]	(1)	max	8.3	15.5	21.2	21.4	19.4
		med	6.8	11.6	17.1	16.6	16.3
		min	4.6	7.5	11.4	12.0	11.2
Heating capacity [kW]	(3)	max	4.62	6.25	8.02	10.75	13.77
		med	4.18	5.42	7.20	9.48	12.67
		min	3.43	4.33	5.90	8.06	10.53
Pressure drop in heating [kPa]	(3)	max	16.0	26.4	17.3	33.0	29.9
		med	13.4	20.4	14.3	26.3	25.7
		min	9.4	13.6	9.9	19.6	18.5
Air flow [m³/h]		max	1250	1750	2350	3040	3860
		med	1040	1340	1920	2400	3300
		min	750	920	1350	1810	2380
Fan [W]		max	144	225	340	530	695
		med	88	115	200	253	384
		min	40	44	80	110	168

(1) Room temperature 27°C d.b., 19°C w.b. - Water temperature 7/12 °C.

(2) Room temperature 20°C - Water temperature 45/40 °C.

(3) Room temperature 20°C - Water temperature 65/55 °C.

(4) The sound pressure levels are 9 dB(A) lower than the sound power levels and apply to the reverberant field of a 100 m³ room and a reverberation time of 0.5 sec.

* Models not covered by EUROVENT certification program.



Manufacturer reserves the rights to change specifications without prior notice.

RFHP-O and RFHPO-ECM

High static pressure blower with centrifugal fan

Compatibility tables

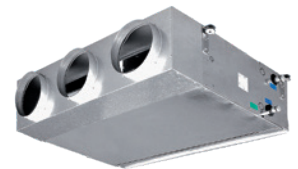

Compatibility table / Codes

Controls for RFHP-O models	14	24	34	44	54	64	74
Remote three speed control WM-3V (1) (4)				9066642			
Remote three speed control + electronic thermostat and manual S/W switch JWC-T (2)				9066630K			
Remote three speed control + electronic thermostat and centralized/manual S/W switch JWC-TQR (2) (3)				9066631K			
Automatic speed control with electronic thermostat and S/W switch - JWC-AU (to be used with UPM-AU and UP-AU only) (2) (3)				9066632K			
Automatic remote control with electronic thermostat, S/W switch and liquid crystall display T-MB (2) (3)				9066331E			
Receiving board for centralized control SEL-S				9079109			
Power unit UPOM1-AU for JWC-AU and T-MB remote controls, fitted on the unit	9034170				-		
Power unit UPOM3-AU for JWC-AU and T-MB remote controls, fitted on the unit	-				9034180		
Power unit UPO1-AU for JWC-AU and T-MB remote controls, not fitted on the unit	9034169				-		
Power unit UPO3-AU for JWC-AU and T-MB remote controls, not fitted on the unit	-				9034179		
Electronic controls for MB boards							
Mounted power unit MB-M (T-MB wall control included)				9066332			
Not mounted power unit MB-S (T-MB wall control included)				9066333			
Multifunction wall control up to 60 units PSM-DI				3021293			
Change-over 15-25 for control JWC-TQR				9053049			
Receiver board for control JWC-T and JWC-TQR				9066311			
Management system for a network of fan coils with MB electronic board							
Hardware/software supervisory system (to be used with MB board only) NET				9079118			
Router-S for NET (default) or for BMS systems no provided by YORK				3021290			
Relay output board SIOS				3021292			
Controls for RFHPO-ECM models	14	24	34	44	54	-	-
Automatic speed control with electronic thermostat and S/W switch - JWC-AU (to be used with UPM-AU and UP-AU only) (2) (3)				9066632K			
Automatic remote control with electronic thermostat, S/W switch and liquid crystall display T-MB (to be used with UPM-AU and UP-AU only) (2) (3)				9066331E			
Power unit UPOM1-AU for JWC-AU and T-MB remote controls, fitted on the unit				9034170			
Power unit UPO1-AU for JWC-AU and T-MB remote controls, not fitted on the unit				9034169			
Electronic controls for MB boards							
Mounted power unit MB-M (T-MB wall control included)				9066332			
Not mounted power unit MB-S (T-MB wall control included)				9066333			
Multifunction wall control up to 60 units PSM-DI				3021293			
Change-over 15-25 for control JWC-TQR				9053049			
Receiver board for control JWC-T and JWC-TQR				9066311			
Management system for a network of fan coils with MB electronic board							
Hardware/software supervisory system (to be used with MB board only) NET				9079118			
Router-S for NET (default) or for BMS systems no provided by YORK				3021290			
Relay output board SIOS				3021292			

(1) Not to be used with valves. (2) Can be used with valves and/or low temperature cut-out.
 (3) Can be used with Change Over. (4) Not suitable with -E electric heater. (5) Can be used with valve and not to be used with low temperature cut-out.

Model RFHP-O	14	24	34	44	54	64	74
Model RFHPO-ECM	14	24	34	44	54	-	-
Accessories (supplied loose)							
Main coil valve kit (220V On/Off)	9034255	9034256		9035147		9034259	
Auxiliary coil valve kit (220V On/Off)			-			9034258	
Main coil 3 way valve kit 24V actuator	9034250	9034251		9034252		9034270	9034272
Auxiliary coil 3 way valve kit 24V actuator		9034253		9034254		9034271	9034273
External auxiliary condensate collection tray				9034029			
Electric heater 230V	9034201	9034210			-		
Electric heater 400V	9034202	9034211	9034222	9034232	9034242	9034204	9034205
Intake/supply spigot plenum	9034200		9034220	9034230	9034240	9034280	9034290
ePM10 50% - G4 class synthetic filter	6034050		6034052	6034053	6034054	6034056	6034057
ePM10 70% - F6 class Synthetic Filter			-			6034197	6034198
Antivibrating connection	6034200	6034201	6034202	6034203	6034204	6034205	

YGFC

Medium static pressure blower

2 and 4 pipe system

A complete range from 1.55 kW up to 11.02 kW



YGFC Series Fan Coil units from Johnson Controls are designed specially to meet the varied requirements of zone cooling or heating using Chilled Water or Hot Water.

YGFC Series can be applied to two or four pipe systems to satisfy the requirements of a wide variety of air conditioning or heating applications. The YGFC is available in concealed version for ceiling installation. It offer effective zone control and is especially suitable for use in apartments, hotels, shopping centers, office buildings and hospitals.

Features

- 10 unit sizes for ceiling mounting
- External static pressure up to 60Pa
- Choice of 2 or 4 pipe systems
- Airflow capacity range from 110 to 2700 m³/h
- Centrifugal direct-drive fans
- 3 speed motor
- Copper tube coils
- Aluminium fins with hydrophilic coating or golden epoxy coated fins available as an option
- Air distribution plenum
- Drain pan
- One configuration: Ceiling with back plenum (CB)
- EUROVENT and AHRI Certified



Selection software

YGFC Medium static pressure blower

1.55 kW to 11.02 kW



Unit performance at 0 Pa external static pressure, with 3 row cooling coil 2 pipe

Model YGFC		02 ST	03 ST	04 ST	05 ST	06 ST	07 ST	08 ST	10 ST	12 ST	14 ST	
Total cooling capacity [kW]	max	2.09	2.97	3.27	4.22	5.40	5.80	7.08	7.42	9.15	11.02	
	med	1.93	2.74	3.06	3.86	4.92	5.23	6.69	6.85	8.37	10.17	
	min	1.55	2.24	2.71	3.39	3.97	4.37	5.75	5.80	6.69	8.51	
Sensible cooling capacity [kW]	max	1.41	2.02	2.22	2.86	3.71	4.03	4.86	5.18	6.46	7.81	
	med	1.29	1.85	2.06	2.59	3.34	3.61	4.57	4.76	5.85	7.12	
	min	1.01	1.47	1.77	2.25	2.64	2.95	3.83	3.95	4.56	5.80	
Power input [W]	max	43	58	70	98	125	128	179	186	241	309	
	med	40	53	63	92	114	116	158	177	222	277	
	min	33	44	55	87	97	104	135	161	193	234	
Water flow in cooling [m³/h]	max	0.361	0.511	0.563	0.727	0.930	0.998	1.219	1.278	1.576	1.898	
	med	0.332	0.471	0.527	0.665	0.846	0.900	1.151	1.179	1.441	1.751	
	min	0.267	0.385	0.465	0.584	0.684	0.753	0.991	1.000	1.153	1.466	
Pressure drop in cooling [kPa]	max	28.2	32.0	30.4	29.1	39.5	27.8	37.8	32.9	37.8	38.7	
	med	25.0	28.5	28.0	27.0	34.1	23.1	34.4	29.2	32.7	34.3	
	min	17.0	20.0	24.3	23.2	25.4	17.8	27.0	23.0	22.6	26.0	
Air flow [m³/h]	max	436	654	737	924	1209	1259	1575	1807	2276	2758	
	med	381	581	648	813	1039	1102	1420	1592	1951	2434	
	min	285	424	522	659	755	844	1109	1190	1389	1784	
Sound power level [dB(A)]	max	51.9	52.0	57.2	60.4	61.9	62.7	62.8	63.6	64.6	66.4	
	med	48.5	48.8	54.4	56.7	58.4	59.2	60.3	60.5	60.0	63.7	
	min	42.5	42.5	49.1	48.3	51.2	51.0	52.9	51.9	52.9	56.3	
Sound pressure level [dB(A)]	max	39.0	39.5	43.0	47.5	49.5	49.3	50.0	50.5	52.2	54.0	
	med	36.0	36.0	41.0	45.0	46.0	47.0	47.0	48.5	48.5	51.5	
	min	28.0	29.2	35.8	36.8	39.3	37.8	41.4	39.4	39.6	43.8	
Air Off FCU	DB °C	max	12.9	13.1	13.1	13.2	13.6	13.6	13.4	13.7	13.9	277
	WB °C	max	12.1	12.3	12.2	12.3	12.6	12.7	12.5	12.8	13.0	234
Power supply [V-ph-Hz]		230 - 1 - 50										

Air Conditions : EDB / EWB 24 / 18°C
 Water Conditions : EWT / LWT 7 / 12°C
 Power Supply: 220V/1Ph./50Hz. delta T 5°C



Manufacturer reserves the rights to change specifications without prior notice.

YGFC Medium static pressure blower

1.55 kW to 11.02 kW

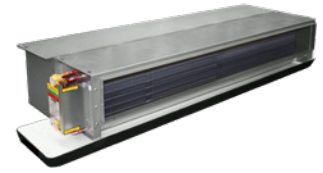

Unit performance at 0 Pa external static pressure, with 3+1 rows coil 4 pipe

Model YGFC		02 ST	03 ST	04 ST	05 ST	06 ST	07 ST	08 ST	10 ST	12 ST	14 ST	
Total cooling capacity [kW]	max	2.03	2.86	3.19	4.00	5.08	5.32	6.79	7.20	8.79	10.54	
	med	1.85	2.59	2.93	3.65	4.64	4.71	6.28	6.53	7.74	9.69	
	min	1.46	2.18	2.56	3.12	3.76	3.93	5.44	5.36	6.26	7.93	
Sensible cooling capacity [kW]	max	1.46	2.06	2.30	2.87	3.72	3.92	4.97	5.38	6.66	8.02	
	med	1.30	1.85	2.08	2.59	3.34	3.42	4.54	4.83	5.75	7.26	
	min	1.00	1.50	1.76	2.17	2.63	2.78	3.80	3.83	4.49	5.69	
Power input in cooling [W]	max	43	58	61	84	122	113	169	174	239	301	
	med	39	52	56	80	113	102	148	167	221	274	
	min	32	43	48	87	96	102	133	161	190	231	
Water flow in cooling [m³/h]	max	0.350	0.492	0.549	0.689	0.875	0.916	1.170	1.239	1.514	1.815	
	med	0.318	0.447	0.505	0.629	0.799	0.812	1.081	1.124	1.333	1.669	
	min	0.252	0.375	0.440	0.538	0.648	0.677	0.936	0.923	1.077	1.366	
Pressure drop in cooling [kPa]	max	26.9	30.1	29.2	26.8	35.8	24.4	35.5	31.4	35.6	36.1	
	med	23.4	26.2	26.1	24.7	31.1	19.8	31.2	27.2	29.1	31.9	
	min	15.5	19.2	22.3	20.4	23.3	15.2	24.8	20.4	20.4	23.4	
Heating capacity [kW]	max	3.59	4.68	5.93	7.08	7.95	8.60	10.37	12.71	14.30	17.03	
	med	3.35	4.33	5.48	6.48	7.27	7.94	9.73	11.65	13.07	16.11	
	min	2.76	3.79	4.71	5.51	5.77	6.89	8.35	9.27	11.10	13.64	
Leaving Water Temperature [°C]	max	47.1	44.6	47.9	46.6	42.4	43.0	42.0	44.3	41.6	41.2	
	med	48.9	45.9	49.3	47.8	43.3	44.9	43.1	45.2	43.7	42.8	
	min	52.5	49.2	51.4	49.1	44.8	47.8	44.9	46.6	47.1	46.2	
Water flow in heating [m³/h]	max	0.309	0.403	0.511	0.609	0.685	0.741	0.893	1.095	1.231	1.466	
	med	0.288	0.373	0.472	0.558	0.626	0.683	0.838	1.003	1.125	1.387	
	min	0.238	0.326	0.406	0.475	0.497	0.593	0.719	0.798	0.956	1.175	
Pressure drop in heating [kPa]	max	70.9	27.6	35.1	48.6	64.8	36.1	51.9	71.4	51.6	74.2	
	med	62.3	24.1	30.3	41.6	55.3	31.4	46.5	60.8	44.0	67.3	
	min	43.6	19.1	23.3	31.5	37.7	24.4	35.6	40.9	33.1	50.3	
Air flow [m³/h]	max	424	620	691	874	1162	1203	1538	1742	2203	2637	
	med	374	544	608	768	999	1036	1389	1538	1835	1353	
	min	274	423	489	624	719	806	1105	1160	1363	1734	
Sound power level [dB(A)]	max	51.9	52.0	57.2	60.4	61.9	62.7	62.8	63.6	64.6	66.4	
	med	48.5	48.8	54.4	56.7	58.4	59.2	60.3	60.5	60.0	63.7	
	min	42.5	42.5	49.1	48.3	51.2	51.0	52.9	51.9	52.9	56.3	
Sound pressure level [dB(A)]	max	39.0	39.5	43.0	47.5	49.5	49.3	50.0	50.5	52.2	54.0	
	med	36.0	36.0	41.0	45.0	46.0	47.0	47.0	48.5	48.5	51.5	
	min	28.0	29.2	35.8	36.8	39.3	37.8	41.4	39.4	39.6	43.8	
Air Off FCU	DB °C	max	13.0	13.2	13.2	13.2	13.5	13.5	13.5	13.7	13.9	14.0
	WB °C	max	12.5	12.7	12.7	12.6	12.9	13.0	12.9	13.2	13.3	13.4
Power supply [V-ph-Hz]		230 - 1 - 50										

Air Conditions : EDB / EWB Cooling 24 / 18°C - Heating 20°C
 Water Conditions : EWT / LWT Cooling 7 / 12°C - Heating 70 / 60°C
 Power Supply: 220V/1Ph./50Hz. delta T 5°C (cooling) 10°C (heating)



Manufacturer reserves the rights to change specifications without prior notice.

Dimensions and Weights

2 Pipe model

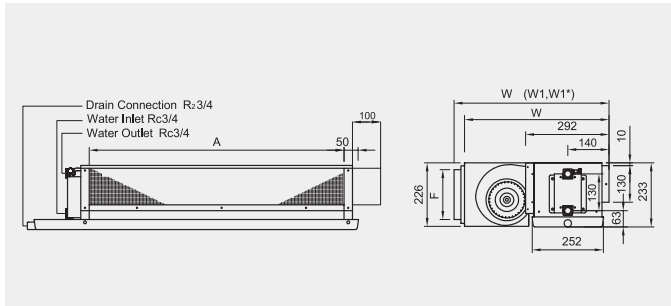

4 Pipe model

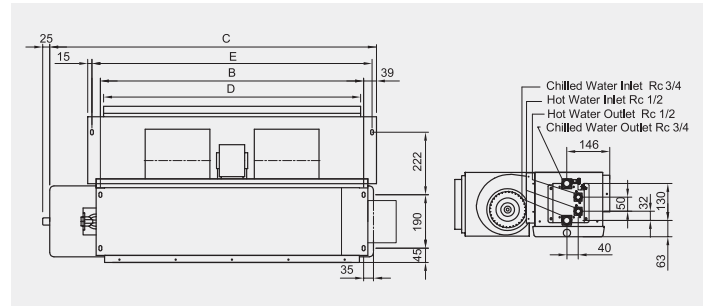

Model	A	B	Length with Standard Drain C	Length with Extended Drain C*	D	E	F	W	Width		Height H	Outlet Flange Dimension	Weight (kg)	
									F1 W1	F2 W1*			3 Rows	3+1,4Rows
YGFC 02 CB 3(4,A)	435	465	630	730	460 (444)	513	190 (202)	507	541	558	233	485 x 130	18.0	19.0
YGFC 03 CB 3(4,A)	585	615	780	880	610 (594)	663	190 (202)	507	541	558	233	635 x 130	20.8	22.1
YGFC 04 CB 3(4,A)	665	695	880	980	690 (674)	743	190 (202)	507	541	558	233	715 x 130	23.4	24.4
YGFC 05 CB 3(4,A)	725	755	930	1030	750 (734)	803	190 (202)	507	541	558	233	775 x 130	24.9	26.0
YGFC 06 CB 3(4,A)	825	855	1030	1130	850 (834)	903	190 (202)	507	541	558	233	875 x 130	27.4	28.6
YGFC 07 CB 3(4,A)	1005	1035	1200	1300	1030 (1014)	1083	190 (202)	507	541	558	233	1055 x 130	36.3	38.5
YGFC 08 CB 3(4,A)	1205	1235	1400	1500	1230 (1214)	1283	190 (202)	507	541	558	233	1255 x 130	38.7	41.1
YGFC 10 CB 3(4,A)	1255	1285	1450	1550	1280 (1264)	1333	190 (202)	507	541	558	233	1305 x 130	40.3	42.5
YGFC 12 CB 3(4,A)	1505	1535	1700	1800	1530 (1514)	1583	190 (202)	507	541	558	233	1555 x 130	45.8	47.7
YGFC 14 CB 3(4,A)	1755	1785	1950	2050	1780 (1764)	1833	190 (202)	507	541	558	233	1805 x 130	56.5	58.5

Notes:

- (1) A is the coil length. (2) B is the distance between the elliptical holes on the coil top panel. (3) C is the length of drain pan. (4) C* is the length of unit including extended drain pan.
- (5) D is the length of return plenum. Data out brackets are for side/ back filter removal, data in brackets are for bottom filter removal.
- (6) E is the distance between the elliptical holes on the return plenum.
- (7) F is the height of return plenum. Data out brackets are for side/ back filter removal, data in brackets are for bottom filter removal.
- (8) Width refers to plenum with filter & inlet flange. (9) W1 for nylon filter (F1), W1* for Al mesh filter (F2). (10) W is the unit width without filter & inlet flange.
- (11) Weights mentioned above are for standard units. For weights including filters and extended drain pan please refer to performance sheets.

Packaged dimensions

Model	Length (mm)	Width (mm)	Height (mm)	Gross Weight (kg)					
				3 Rows		3+1,4 Rows			
CB (3,4,3+1) Standard	YGFC 02	680	570	240	20.3	21.3			
	YGFC 03	830	570	240	23.5	24.8			
	YGFC 04	930	570	240	26.5	27.5			
	YGFC 05	980	570	240	28.2	29.3			
	YGFC 06	1100	570	240	30.6	31.8			
	YGFC 07	1270	570	240	40.4	42.6			
	YGFC 08	1470	570	240	43.1	45.5			
	YGFC 10	1520	570	240	45.1	47.3			
	YGFC 12	1770	570	240	51.3	52.9			
	YGFC 14	2020	570	240	62.9	65.2			
	CB (3,4,3+1) with Extended Drain Pan	YGFC 02	780	570	240	20.6	22.4	21.6	23.4
		YGFC 03	930	570	240	23.8	25.6	25.1	26.9
		YGFC 04	1030	570	240	26.8	28.6	27.8	29.6
		YGFC 05	1080	570	240	28.4	30.3	29.5	31.4
YGFC 06		1200	570	240	30.9	32.7	32.1	33.9	
YGFC 07		1370	570	240	40.7	42.5	42.9	44.7	
YGFC 08		1570	570	240	43.4	45.2	45.8	47.6	
YGFC 10		1620	570	240	45.4	47.2	47.6	49.4	
YGFC 12		1870	570	240	51.6	53.4	53.2	55.0	
YGFC 14		2120	570	240	63.2	65.0	65.5	67.3	

Notes: Weights of CB units with standard drain pan

YDFC

High static pressure blower

2 pipe system

A complete range from 4.79 kW up to 18.06 kW

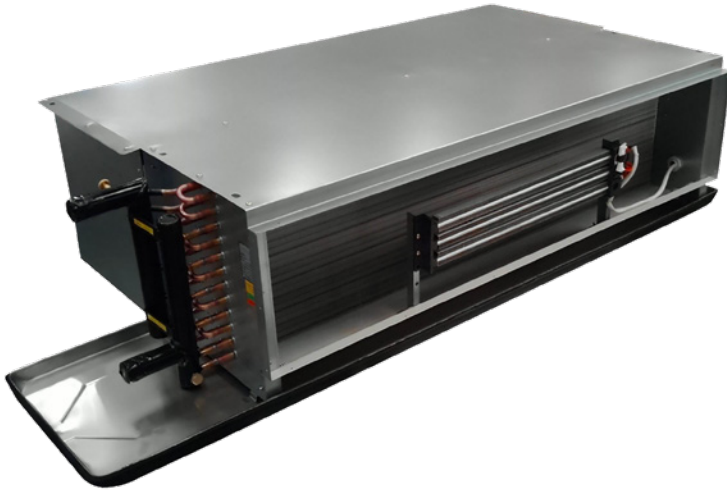

YDFC Series Fan Coil units are ceiling mounted, high air flow, high static pressure air conditioning terminals. They are designed, developed and tested considering tougher weather conditions makes them an ideal solution of year round air conditioning, heating and ventilating requirements.

YDFC units are designed and manufactured to the high standards that are expected of a product from Johnson Controls, having an up to date style and advanced structure. They are highly efficient, quiet, cost effective, safe, reliable and offer ease and economy in installation.

YDFC high air flow fan coils are available in 7 sizes, for customers to choose from for standard applications, with 2 pipe system and 4 rows.

Features

- 7 unit sizes for ceiling mounting
- External static pressure up to 160Pa
- 2 pipe system with 4 row coil
- Airflow capacity range from 680 to 3500 m³/h
- Centrifugal direct-drive fans
- 3 speed motor
- Copper tube coils
- Aluminium fins with hydrophilic coating or golden epoxy coated fins available as an option
- Air distribution plenum
- Drain pan
- One configuration: Ceiling with back plenum (CB)
- EUROVENT and AHRI Certified



Selection software

YDFC High static pressure blower

4.79 kW to 18.06 kW



Unit performance at 20 Pa external static pressure, with 4 row cooling coil 2 pipe

Model YDFC		08 ST	10 ST	12 ST	14 ST	16 ST	18 ST	20 ST	
Total cooling capacity [kW]	max	7,10	9,48	11,47	13,63	15,38	17,13	18,06	
	med	6,98	9,22	11,15	12,99	15,08	16,67	17,53	
	min	4,79	6,34	7,39	7,99	10,64	11,31	11,58	
Sensible cooling capacity [kW]	max	5,02	6,63	7,90	9,55	10,92	11,99	13,06	
	med	4,90	6,38	7,66	9,01	10,65	11,58	12,63	
	min	3,15	4,35	4,96	5,36	7,10	7,44	7,87	
Power input [W]	max	280	366	461	649	695	770	887	
	med	267	333	429	591	653	684	837	
	min	129	193	184	218	314	324	385	
Water flow in cooling [m³/h]	max	1,223	1,632	1,976	2,346	2,649	2,949	3,110	
	med	1,201	1,587	1,920	2,237	2,596	2,870	3,018	
	min	0,824	1,092	1,273	1,376	1,832	1,948	1,994	
Pressure drop in cooling [kPa]	max	21,0	46,0	39,4	42,2	25,9	35,6	20,5	
	med	20,0	41,0	36,9	40,1	25,4	34,6	19,7	
	min	10,2	22,7	18,0	15,9	12,9	16,7	9,4	
Air flow [m³/h]	max	1459	2004	2405	2851	3323	3518	4026	
	med	1419	1879	2240	2727	3202	3344	3875	
	min	829	1106	1244	1315	1816	1875	2059	
Sound power level [dB(A)]	max	69,4	70,4	69,3	73,4	71,0	70,1	72,9	
	med	68,6	67,9	67,9	72,3	70,8	69,5	71,5	
	min	55,4	54,9	54,8	55,8	58,9	57,5	58,2	
Sound pressure level [dB(A)]	max	55,7	56,6	55,3	59,3	56,8	55,8	58,4	
	med	54,9	54,0	54,0	58,2	56,6	55,2	57,1	
	min	41,7	41,2	41,0	42,0	44,8	43,4	43,9	
Dimensions	Height	mm	295	295	345	345	396	396	396
	Length (Standard drain pan)	mm	1050	1210	1210	1340	1340	1480	1610
	Length (Extended drain pan)	mm	1210	1340	1340	1480	1480	1610	1710
	Width	mm	775	775	775	775	815	815	815
Weight	kg	49	51	59	65	77	92	97	
Air Off FCU	DB °C	max	13,2	13,2	12,9	13,3	13,5	13,2	13,7
	WB °C	max	12,5	12,5	12,2	12,6	12,7	12,5	12,9
Power supply [V-ph-Hz]	220 - 1 - 50								

Air Conditions : EDB / EWB 24 / 18°C
 Water Conditions : EWT / LWT 7 / 12°C
 Delta T 5°C

Dimensions

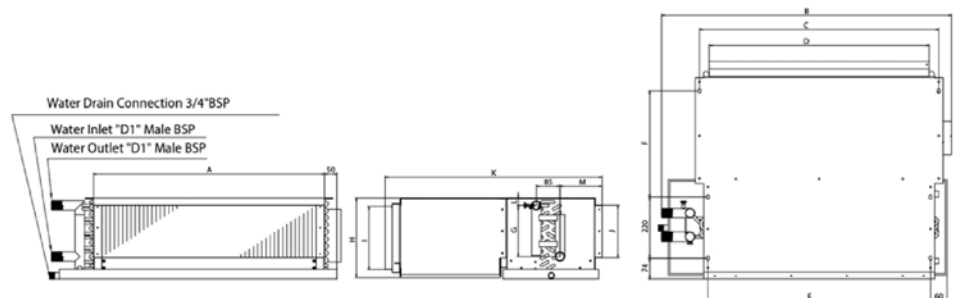

Model	A	B	B1	C	D	E	F	G	H	I	J	K	L	D1	M4R	O
YDFC 08	830	1050	1210	860	768	800	380	184	289	225	190	775	27	25	151	84
YDFC 10	990	1210	1340	1020	928	960	380	184	289	225	190	775	27	25	151	84
YDFC 12	990	1210	1340	1020	928	960	380	235	340	275	240	775	27	25	151	109
YDFC 14	1120	1340	1480	1150	1058	1090	380	235	340	275	240	775	27	25	151	109
YDFC 16	1120	1340	1480	1150	1058	1090	420	279	390	325	280	815	33	38.1	151	134
YDFC 18	1260	1480	1610	1290	1198	1230	420	279	390	325	280	815	33	38.1	151	134
YDFC 20	1390	1610	1710	1420	1328	1360	420	279	390	325	280	815	33	38.1	151	134

Notes: (1) B is the length of drain pan. (2) B1 is length of unit including extended drain pan. (3) All dimensions are in mm.



Manufacturer reserves the rights to change specifications without prior notice.

YEFB

High static pressure blower

2 and 4 pipe system

A complete range from 4.3 kW up to 27.5 kW



CSR00 (Wall mounted)
Fan speed selector



CMR00 (Wall mounted)
Thermostat with manual fan speed and S/W change over



CER00 (Wall mounted)
Thermostat with manual fan speed and automatic change over

CER20 (Wall mounted)
Thermostat with auto. fan speed and automatic change over

CER30 (Wall mounted)
Thermostat with auto. fan speed and automatic change over for modulating valve



TUC03+ Terminal unit controller
BacNET and N2 Metasys network compatible



YEFB Blower units are available in 6 sizes for horizontal concealed installations: thanks to their high ESP fans that can handle up to 250Pa, they are the ideal solution for air conditioning large spaces.



Selection software

Features

- 6 unit sizes for horizontal mounting
- Handles high external static pressure up to 250Pa
- Choice of 2 or 4 pipe systems
- Twin centrifugal fans
- Horizontal air return
- Air distribution plenum
- Electric heater option
- Optional paint finish
- F5 grade filter option
- 5 Row cooling coil option on sizes 060, 070
- EUROVENT Certified

YEFB High static pressure blower

4.3 kW to 27.5 kW



Unit performance at different Pa external static pressure, with 4 row cooling coil

Model YEFB		020-4	030-4	040-4	050-4	060-4*	070-4*
Total cooling capacity [kW]	(1) max	6.95	9.49	11.77	13.72	23.83	27.52
	med	5.90	8.23	10.35	12.6	21.59	25.55
	min	4.30	7.11	8.91	11.36	17.15	23.56
Sensible cooling capacity [kW]	(1) max	4.99	7.91	9.94	11.80	18.89	22.00
	med	4.14	6.7	8.61	10.60	16.84	20.27
	min	2.98	5.68	7.17	9.44	12.93	18.54
Water flow in cooling [l/h]	(1) max	1195	1632	2024	2360	4099	4699
	med	1015	1416	1780	2167	3714	4361
	min	740	1223	1533	1954	2950	4018
Pressure drop in cooling [kPa]	(1) max	17.4	31.5	30.6	40.4	28.0	37.5
	med	12.2	24.1	23.3	33.8	23.2	33.0
	min	6.5	18.4	17.9	28.3	15.1	28.7
Heating capacity 2 pipes [kW]	(2) max	7.08	11.40	14.32	17.4	28.08	33.85
	med	6.20	9.62	12.19	15.53	24.95	30.95
	min	4.55	8.20	10.4	13.85	18.9	28.09
Water flow in heating 2 pipes [l/h]	(2) max	1219	1962	2465	2727	4495	5855
	med	1067	1656	2098	2673	4034	5354
	min	783	1411	1788	2392	3047	4858
Pressure drop in heating 2 pipes [kPa]	(2) max	13.3	34.0	36.1	51.0	30.2	49.6
	med	10.3	25.7	26.9	41.3	23.5	42.4
	min	4.8	19.2	20.0	33.4	14.6	35.7
Air flow [m³/h]	max	1145	1910	2680	3250	4120	5512
	med	920	1520	2130	2870	3610	4936
	min	620	1205	1655	2470	2580	4383
Sound power level [dB(A)]	max	64.0	65.0	69.0	72.0	77.0	81.0
	med	58.0	61.0	63.0	68.0	74.0	79.0
	min	48.0	57.0	57.0	65.0	65.1	76.0
Sound pressure level [dB(A)]	(3) max	53.0	54.0	58.0	61.0	66.0	70.0
	med	47.0	50.0	52.0	57.0	63.0	68.0
	min	37.0	46.0	46.0	54.0	54.0	65.0
Power supply [V-ph-Hz]		230 / 1 / 50					
Power input [W]	max	171	352	451	588	1007	1 781
Absorbed current [A]	max	0.74	1.62	2.05	2.83	4.47	7.90
Dimensions	Height mm	407.6	407.6	407.6	407.6	517.6	517.6
	Width mm	902	902	902	902	1 160	1 160
	Depth mm	989.6	989.6	1 239.6	1 239.6	1 634.6	1 634.6

(1) Room temperature 27°C d.b., 19°C w.b. - Water temperature 7/12 °C

(2) Room temperature 20°C - Water inlet temperature: 45/40°C

(3) Lp= Total sound pressure level in open field at 1 m from the source

For each unit size there are 2, 3 and 4 row coils available; for 4 pipe systems it is possible to install a 2 or 3 row coil. It is therefore possible to have a combination of maximum 7 rows (4 row cooling + 3 row heating). For models 060 and 070 are also 5 row coils available, which can be combined with additional 2 or 3 row coils.

* Models not covered by EUROVENT certification program.



Manufacturer reserves the rights to change specifications without prior notice.

YEFB-ECM

Inverter high static pressure blower

2 and 4 pipe system

A complete range from 4.2 kW up to 23.8 kW



YEFB-ECM high pressure ducted fan coils with energy saving motors, are specifically designed for ducted installations, with external static pressure up to 300 Pa. Their high pressure fan decks permit to satisfy every request of heating and cooling application in big environments.

The YEFB-ECM high pressure fan coil units are available in 5 sizes for concealed horizontal installation, in 2 and 4 pipe systems. For each unit size there are 2, 3 and 4 row coils available and models 060 are also 5 row coils available, which can be combined with additional 2 or 3 row coils.



EDCR (Wall mounted)

Thermostat with manual or automatic fan speed and automatic change over for modulating valve



TUC03+ Terminal unit controller

BacNET and N2 Metasys network compatible



Features

- 5 unit sizes for horizontal mounting
- Handles high external static pressure up to 300Pa
- Choice of 2 or 4 pipe systems
- Twin centrifugal fans
- Horizontal air return
- Air distribution plenum
- Electric heater option
- Optional paint finish
- F5 grade filter option
- 5 Row cooling coil option on size 060
- EUROVENT Certified



Selection software

YEFB-ECM Inverter high static pressure blower

4.2 kW to 23.8 kW



ECM the Energy Saving Technology

Brushless motor with inverter managed by dedicated controls. It permits to maintain extremely low electrical absorption and a continuous modulation of the air flow.

Unit performance at different Pa external static pressure, with 4 row cooling coil

Model YEFB-ECM		020-4	030-4	040-4	050-4	060-4*	
Total cooling capacity [kW]	(1)	max	6.75	9.94	13.64	14.40	23.82
		med	5.62	8.13	11.22	13.25	20.32
		min	4.23	7.11	8.43	11.90	18.79
Sensible cooling capacity [kW]	(1)	max	5.27	7.98	11.17	11.94	18.76
		med	4.30	6.34	10.82	10.82	15.78
		min	3.16	5.47	6.46	9.56	14.49
Water flow in cooling [l/h]	(1)	max	1162	1711	2348	2478	4088
		med	812	1399	1931	2281	3488
		min	728	1224	1451	2048	3224
Pressure drop in cooling [kPa]	(1)	max	16.5	35.4	45.0	50.9	30.8
		med	11.6	24.0	30.6	42.9	23.4
		min	6.8	18.8	17.7	34.7	20.5
Heating capacity 2 pipes [kW]	(2)	max	7.07	11.52	16.24	18.07	28.00
		med	5.65	9.07	12.87	16.25	23.25
		min	4.11	7.81	9.35	14.37	21.23
Water flow in heating 2 pipes [l/h]	(2)	max	1217	1983	2795	3110	4866
		med	972	1561	2215	2797	4041
		min	707	1344	1609	2473	3689
Pressure drop in heating 2 pipes [kPa]	(2)	max	15.4	39.1	53.2	65.7	32.1
		med	10.4	25.4	34.8	54	23.2
		min	5.8	19.3	19.3	43.1	19.8
Air flow [m³/h]		max	1040	1948	2848	3217	4521
		med	796	1471	2160	2834	3599
		min	549	1241	1484	2442	2972
Sound power level [dB(A)]		max	65	68	71	75	76
		med	58	61	66	72	77
		min	49	57	57	69	74
Sound pressure level [dB(A)]	(3)	max	54	57	60	64	70
		med	47	50	55	61	66
		min	38	46	46	58	63
Power supply [V-ph-Hz]		230 - 1 - 50/60 **					
Power input [W]	max	161	261	405	478	926	
Absorbed current [A]	max	1.08	1.12	1.85	2.17	4.16	
Dimensions	Height	mm	407.6	407.6	407.6	407.6	517.6
	Width	mm	902	902	902	902	1 160
	Depth	mm	989.6	989.6	1 239.6	1 239.6	1 634.6

(1) Room temperature 27°C d.b., 19°C w.b. - Water temperature 7/12 °C

(2) Room temperature 20°C - Water inlet temperature: 45/40°C

(3) Lp= Total sound pressure level in open field at 1 m from the source

4 pipe system not available with 4R heating coil

* Models not covered by EUROVENT certification program.

** For a correct selection at 60 Hz of the units, pls use the YORK software for selection.



Manufacturer reserves the rights to change specifications without prior notice.

YEFB Hydro Blower

YEFB-ECM Inverter Hydro Blower

Compatibility tables



Compatibility Options / Accessories / Models

Code	Designation	YEFB / YEFB-ECM					
		020	030	040	050	060	070
Coils and heaters**							
BA2	Additional 2 row heating	•	•	•	•	•	•
BA3	Additional 3 row heating	•	•	•	•	•	•
KREL	Kit electrical heater with safety thermostat and relay	•	•	•	•	•	•
Factory fitted electric box							
CBL10	Transformer 230/24V	•	•	•	•	•	•
CBL20	Parallel connection for ON/OFF valve	•	•	•	•	•	•
CBL30	Parallel connection for modulating valve	•	•	•	•	•	•
Remote controllers and thermostats (wall mounted)							
CSR00	Fan speed selector (wall mounted)	•	•	•	•	•	•
CMR00	Thermostat with manual fan speed and S/W change over	•	•	•	•	•	•
CER00	Thermostat with manual fan speed, dead band, automatic change over	Compatible with electrical heaters					
CER20	Thermostat with automatic fan speed, dead band, automatic change over	Compatible with electrical heaters					
CER30	Thermostat with automatic fan speed, dead band, automatic change over for modulating valves	•	•	•	•	•	•
EDCR	Thermostat with manual or automatic fan speed, dead band, automatic change over for modulating valves - Only for ECM models	Compatible with electrical heaters					
OxT+OC716	Omnibus control + Remote Analogue Plus	Compatible with electrical heaters					
OxT+OC216	Omnibus control + Remote Display console	Compatible with electrical heaters					
Valves (Supplied loose) / Condensate pump / Water sensor (Factory fitted)							
J3B2 (2p)	3-way 4-ports on/off valves for 2-pipe systems	•	•	•	•		
J3B2 (4p)	3-way 4-ports on/off valves for 4-pipe systems	•	•	•	•		
J3C2 (2p)	3-way 4-ports on/off valves for 2-pipe systems					•	•
J3C2 (4p)	3-way 4-ports on/off valves for 4-pipe systems					•	•
J3BM (2p)	3-way 4-ports modulating valves for 2-pipe systems	•	•	•	•		
J3BM (4p)	3-way 4-ports modulating valves for 4-pipe systems	•	•	•	•		
J3CM (2p)	3-way 4-ports modulating valves for 2-pipe systems					•	•
J3CM (4p)	3-way 4-ports modulating valves for 4-pipe systems					•	•
J2B2 (2p)	2-way on/off valves for 2-pipe systems	•	•	•	•		
J2B2 (4p)	2-way on/off valves for 4-pipe systems	•	•	•	•		
J2C2 (2p)	2-way modulating valves for 2-pipe systems					•	•
J2C2 (4p)	2-way modulating valves for 4-pipe systems					•	•
DTB (2p)	Shut-off valves for 2-pipe systems supplied loose in addition to J3B2 and J3BM valves	•	•	•	•		
DTB (4p)	Shut-off valves for 4-pipe systems (in addition to J3B2/J3BM valves)	•	•	•	•		
PC	Condensate pump	•	•	•	•	•	•
AS	Air sensor	•	•	•	•	•	•
WS	Water sensor	Compatible with CEL/CER/EDCR					
Plenums							
PAS	Air intake plenum collars	•	•	•	•	•	•
PM	Air delivery plenum with collars	•	•	•	•	•	•
PM + Grill	Air delivery plenum painted with air outlet grill	•	•	•	•	•	•

- Compatible
- ◻ Compatible with conditions
- ◻ Not compatible

Dimensions & Weights

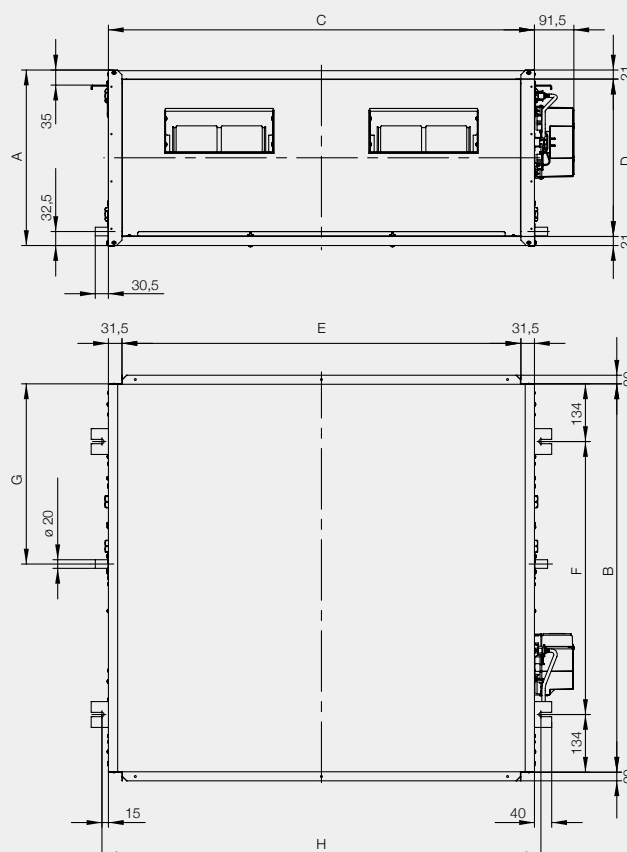

All dimensions in mm. Drawings not in scale.

Model YEFB / YEFB-ECM		020-4	030-4	040-4	050-4	060-4	070-4
A	mm	407.6	407.6	407.6	407.6	517.6	517.6
B	mm	902	902	902	902	1160	1160
C	mm	989.6	989.6	1239.6	1239.6	1634.6	1634.6
D	mm	365.6	365.6	365.6	365.6	475.6	475.6
E	mm	926.6	926.6	1176.6	1176.6	1571.6	1571.6
F	mm	634	634	634	634	892	892
G	mm	418.5	418.5	418.5	418.5	446.5	446.5
H	mm	1019.6	1019.6	1269.6	1269.6	1664.6	1664.6
Weight (3R - 3 rows)	kg	64.3	64.3	79.3	79.3	126.0	126.0

Model YEFB		(2-3-4 rows)	(2-3-4 rows)	(2-3-4 rows)	(2-3-4 rows)	(2-3-4-5 rows)	(2-3-4-5 rows)
Weight of the coil	kg	4.8 - 5.8 - 7.6	4.8 - 5.8 - 7.6	5.6 - 7.4 - 9.6	5.6 - 7.4 - 9.6	9.4 - 12.8 - 17.4 - 21.5	9.4 - 12.8 - 17.4 - 21.5
Water connection		G1/2" F	G1/2" F	G1/2" F	G1/2" F	G1" M	G1" M
Model YEFB-ECM		(2-3-4 rows)	(2-3-4 rows)	(2-3-4 rows)	(2-3-4 rows)	(2-3-4-5 rows)	-
Weight of the coil	kg	4.8 - 5.8 - 7.6	4.8 - 5.8 - 7.6	5.6 - 7.4 - 9.6	5.6 - 7.4 - 9.6	9.4 - 12.8 - 17.4 - 21.5	-
Water connection		G1/2" F	G1/2" F	G1/2" F	G1/2" F	G1" M	-

Model YEFB		(2-3-4 rows)	(2-3-4 rows)	(2-3-4 rows)	(2-3-4 rows)	(2-3-4-5 rows)	(2-3-4-5 rows)
Water content	l	1.4 - 2.2 - 2.9	1.4 - 2.2 - 2.9	1.9 - 2.8 - 3.8	1.9 - 2.8 - 3.8	3.4 - 5.0 - 6.7 - 8.4	3.4 - 5.0 - 6.7 - 8.4
Model YEFB-ECM		(2-3-4 rows)	(2-3-4 rows)	(2-3-4 rows)	(2-3-4 rows)	(2-3-4-5 rows)	-
Water content	l	1.5 - 2.2 - 2.9	1.4 - 2.2 - 2.9	1.9 - 2.8 - 3.8	1.9 - 2.8 - 3.8	3.4 - 5.0 - 6.7 - 8.4	-

YKEY and YKEY900 Hydro Cassette

2 and 4 pipe system

A complete range from 1.1 kW to 10 kW



The YORK YKEY Cassette units are designed for installation on a false ceiling, suitable for cooling and heating applications.

The ambient air drawn through the central air intake grill is blown into the circular heat exchanger, composed by copper pipes and aluminium fins, and then it comes out from the 4 sides of the cassette unit. Thanks to the special combination of air intake/air outlet grilles it is possible to obtain the pleasant COANDA effect.



CSR00 (Wall mounted)
Fan speed selector



CER00 (Wall mounted)
Thermostat with manual fan speed and automatic change over



CER20 (Wall mounted)
Thermostat with auto. fan speed and automatic change over

CMR00 (Wall mounted)
Thermostat with manual fan speed and S/W change over

CER30 (Wall mounted)
Thermostat with auto. fan speed and automatic change over for modulating valve



TUC03+ Terminal unit controller
BacNET and N2 Metasys network compatible



Features

- Cooling duty from 1.4 to 10 kW
- 2 and 4 pipes systems in all range
- Central air intake grill
- 4 sides air outlet plenum
- 2 panel sizes: 600 x 600 & 900 x 900
- Possible choice between 6 fan speeds
- Condensate pump integrated in all range
- 2/3 way valves fitted or supplied loose in all range
- Coloured versions, possible to change the colour of the grill and the frame
- Possible to select a complete range of controls
- Electric heater fitted as an option for 2 pipe range
- All metal parts insulated to avoid condensations
- EUROVENT Certified

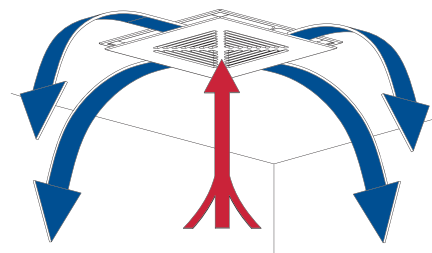

COANDA effect

The particular shape of the air outlet plenum is designed specifically in order to obtain the Coanda effect, a phenomenon for which the air outlet flow tends to adhere to the ceiling and falls down smoothly, without blowing directly towards people in the room: the optimal solution for an uniform and pleasant air diffusion.



YKEY/M Special version with micro-drilled metallic grill



YKEY/H-Special version with natural condensate water discharge



Selection software

YKEY and YKEY900 Hydro Cassette

1.1 kW to 10 kW

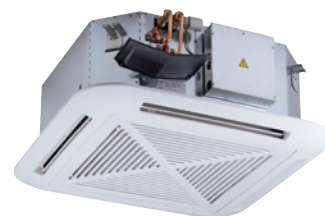

Technical features

YKEY model -2 pipes			621	622	623	921	922
Total cooling capacity [kW]	(1)	max	2.52	3.68	4.72	8.63	9.99
		med	1.78	2.84	3.82	6.49	8.24
		min	1.42	2.27	2.51	3.86	5.65
Sensible cooling capacity [kW]	(1)	max	2.12	2.79	3.7	6.1	7.64
		med	1.4	2.06	2.89	4.49	6.2
		min	1.08	1.63	1.81	2.61	4.13
Water flow in cooling [l/h]	(1)	max	433	633	812	1484	1718
		med	306	488	657	1116	1417
		min	244	390	432	664	972
Pressure drop in cooling [kPa]	(1)	max	7.8	10.9	16.5	20.1	26
		med	4.6	7.3	11.5	12.3	19
		min	3.2	5.2	6	4.5	9
Heating capacity [kW]	(2)	max	2.66	3.65	4.89	8.33	10.18
		med	1.78	2.7	3.8	5.7	7.91
		min	1.38	2.09	2.39	3.25	5.04
Water flow in heating [l/h]	(2)	max	458	628	841	1433	1751
		med	306	464	654	980	1361
		min	237	359	411	559	867
Pressure drop in heating [kPa]	(2)	max	7	9.4	14.9	12.1	17.4
		med	3.4	5.3	9.5	6.1	11
		min	2.2	2	4.1	2.2	4.9
Water content [l]		1.34	2.12	2.12	4.26	4.26	

YKEY model -4 pipes			641	642	643	941	942
Total cooling capacity [kW]	(1)	max	1.76	3.11	3.88	7.49	9.04
		med	1.34	2.48	3.23	5.67	7.5
		min	1.1	2.04	2.25	3.41	5.2
Sensible cooling capacity [kW]	(1)	max	1.62	2.49	3.24	5.98	7.46
		med	1.17	1.91	2.61	4.42	6.08
		min	0.94	1.52	1.73	2.58	4.08
Water flow in cooling [l/h]	(1)	max	303	535	667	1288	1555
		med	230	427	556	975	1290
		min	189	351	387	587	894
Pressure drop in cooling [kPa]	(1)	max	7.5	11.2	16.7	23.2	32
		med	4.8	7.8	11.9	14.1	23
		min	3.6	5.7	6.6	5	12
Heating capacity [kW]	(3)	max	2.01	2.69	3.31	6.66	7.86
		med	1.47	2.2	2.84	5.32	6.75
		min	1.23	1.82	2.01	3.49	4.95
Water flow in heating [l/h]	(3)	max	173	231	285	573	676
		med	126	189	244	458	581
		min	106	157	173	300	426
Pressure drop in heating [kPa]	(3)	max	5.8	10.6	15.2	25	33.2
		med	3.3	7.4	11.8	15.9	25.6
		min	2.4	5.2	6.3	7.9	14.7
Water content [l]		1.34	2.12	2.12	4.26	4.26	

Common features			641	642	643	941	942
Air flow [m³/h]		max	566	566	717	1420	1530
		med	351	351	525	813	960
		min	182	182	308	410	477
Sound power level [dB(A)]		max	49	49	58	54	63
		med	34	40	50	45	55
		min	30	34	37	30	40
Sound pressure level [dB(A)]		max	39.5	39.5	48.5	44.5	53.5
		med	24.5	30.5	40.5	35.5	45.5
		min	20.5	24.5	27.5	20.5	30.5
Power supply [V-ph-Hz]				230 /1 /50			
Power input [W]	max	52	52	86	127	161	
Absorbed current [A]	max	0.25	0.25	0.38	0.62	0.68	
Dimensions	Height	mm	328	328	328	360	360
	Width	mm	575	575	575	820	820
	Depth	mm	575	575	575	820	820

(1) Room temperature 27°C d.b., 19°C w.b. - Water temperature 7/12 °C

(2) Room temperature 20°C - Water temperature: 45/40 °C

(3) Room temperature 20°C - Water inlet temperature: 65/55°C

The sound pressure levels are 9 dB(A) lower than the sound power levels and apply to the reverberant field of a 100 m³ room and a reverberation time of 0.5 sec.



Manufacturer reserves the rights to change specifications without prior notice.

YKEY-ECM and YKEY900-ECM Inverter Cassette

2 and 4 pipe system

A complete range from 1.2 kW to 10.2 kW



EDCR (Wall mounted)

Thermostat with manual or automatic fan speed and automatic change over for modulating valve



TUC03+ Terminal unit controller

BacNET and N2 Metasys network compatible



The YORK YKEY-ECM Cassette units, with energy saving motors, are designed for installation on a false ceiling, suitable for cooling and heating applications.

The ambient air drawn through the central air intake grill is blown into the circular heat exchanger, composed by copper pipes and aluminium fins, and then it comes out from the 4 sides of the cassette unit. Thanks to the special combination of air intake/air outlet grilles it is possible to obtain the pleasant COANDA effect.

Features

- Cooling duty from 1.2 to 10.2 kW
- Brushless motor and inverter technology
- 2 and 4 pipes systems in all range
- Central air intake grill
- 4 sides air outlet plenum
- 2 panel sizes: 600 x 600 & 900 x 900
- Possible choice between 6 fan speeds
- Condensate pump integrated in all range
- 2/3 way valves fitted or supplied loose in all range
- Coloured versions, possible to change the colour of the grill and the frame
- Possible to select a complete range of controls
- Electric heater fitted as an option for 2 pipe range
- All metal parts insulated to avoid condensations
- EUROVENT Certified



YKEY/M-ECM Special version with micro-drilled metallic grill



YKEY/H-ECM Special version with natural condensate water discharge

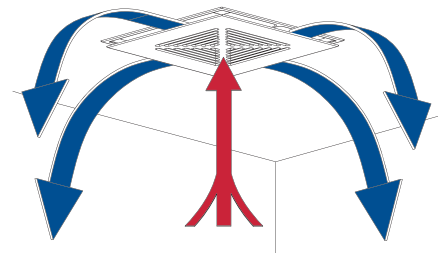

COANDA effect

The particular shape of the air outlet plenum is designed specifically in order to obtain the Coanda effect, a phenomenon for which the air outlet flow tends to adhere to the ceiling and falls down smoothly, without blowing directly towards people in the room: the optimal solution for an uniform and pleasant air diffusion.



Selection software

YKEY-ECM and YKEY900-ECM Inverter Cassette

1.2 kW to 10.2 kW



ECM the Energy Saving Technology

Brushless motor with inverter managed by dedicated controls. It permits to maintain extremely low electrical absorption and a continuous modulation of the air flow.

Technical features

YKEY-ECM model -2 pipes			621	622	624	922.1
Total cooling capacity [kW]	(1)	max	2.85	4.85	5.43	10.15
		med	2.37	3.64	3.99	7.61
		min	1.63	2.56	2.76	4.66
Sensible cooling capacity [kW]	(1)	max	2.42	3.79	4.17	7.87
		med	1.93	2.69	2.98	5.66
		min	1.26	1.85	1.99	3.34
Water flow in cooling [l/h]	(1)	max	491	835	935	1747
		med	408	627	687	1310
		min	281	441	475	802
Pressure drop in cooling [kPa]	(1)	max	9.2	17.2	40.5	23.2
		med	6.9	10.6	23.2	13.9
		min	3.9	6.1	12.3	5.8
Heating capacity [kW]	(2)	max	2.99	4.91	5.44	10.31
		med	2.38	3.52	3.98	7.51
		min	1.59	2.33	2.62	4.45
Water flow in heating [l/h]	(2)	max	515	845	936	1775
		med	410	606	686	1293
		min	274	401	455	766
Pressure drop in heating [kPa]	(2)	max	9	16.2	35.7	21.0
		med	5.9	8.9	20.4	12.0
		min	2.9	4.2	9.5	4.5
Water content [l]		1.34	2.12	2.15	4.26	

YKEY-ECM model -4 pipes			641	642	644	942.1
Total cooling capacity [kW]	(1)	max	1.87	3.52	4.30	9.10
		med	1.68	2.75	3.30	6.85
		min	1.22	2.03	2.32	4.32
Sensible cooling capacity [kW]	(1)	max	1.73	3.32	3.53	7.34
		med	1.52	2.5	2.58	5.33
		min	1.08	1.73	1.71	3.21
Water flow in cooling [l/h]	(1)	max	322	678	740	1566
		med	289	530	568	1179
		min	210	391	399	744
Pressure drop in cooling [kPa]	(1)	max	7.9	17	19.8	24.3
		med	6.6	11	12.5	14.5
		min	4.1	6.7	7.3	6.3
Heating capacity [kW]	(3)	max	2.21	3.3	3.72	7.48
		med	1.84	2.64	2.98	6.13
		min	1.37	2.04	2.23	4.41
Water flow in heating [l/h]	(3)	max	190	284	320	644
		med	158	227	256	528
		min	118	176	192	380
Pressure drop in heating [kPa]	(3)	max	7.1	15.6	19.6	26.2
		med	5.2	10.5	13.4	18.5
		min	3	6.6	8.1	10.2
Water content [l]		1.34	2.12	2.12	4.26	

Common features			641	642	644	942.1
Air flow [m³/h]		max	605	734	809	1497
		med	425	492	536	867
		min	235	260	260	384
Sound power level [dB(A)]		max	55	59	62	62
		med	47	49	51	51
		min	32	39	39	34
Sound pressure level [dB(A)]		max	45.6	49.6	52.6	52.6
		med	37.6	39.6	41.6	41.6
		min	22.6	29.6	29.6	24.6
Power supply [V-ph-Hz]			230 / 1 / 50			
Power input [W]	max	27	43	53	98	
Absorbed current [A]	max	0.25	0.39	0.46	0.80	
Dimensions	Height	mm	328	328	328	360
	Width	mm	575	575	575	820
	Depth	mm	575	575	575	820

(1) Room temperature 27°C d.b., 19°C w.b. - Water temperature 7/12 °C

(2) Room temperature 20°C - Water temperature: 45/40 °C

(3) Room temperature 20°C - Water inlet temperature: 65/55°C

The sound pressure levels are 9 dB(A) lower than the sound power levels and apply to the reverberant field of a 100 m³ room and a reverberation time of 0.5 sec.



Manufacturer reserves the rights to change specifications without prior notice.

YKEY and YKEY900 Cassette

YKEY-ECM and YKEY900-ECM Inverter Cassette

Compatibility tables

Compatibility Options / Accessories / Models

Code	Designation	YKEY models						YKEY-ECM models					
		621	622	623	-	921	922	641	642	643	-	941	942

Heaters														
KREL	Kit electrical heater with safety thermostat and relay	•	•	•	•	•	•	•						

Remote controllers and thermostats (wall mounted)														
CSR00	Fan speed selector (wall mounted) (not for ECM models)	•	•	•			•	•	•	•	•		•	•
CMR00	Thermostat with manual fan speed and S/W change over (not for ECM models)	•	•	•			•	•	•	•	•		•	•
CER00	Thermostat with manual fan speed, dead band, automatic change over (not for ECM models)	Compatible with electrical heaters												
CER20	Thermostat with automatic fan speed, dead band, automatic change over (not for ECM models)	Compatible with electrical heaters												
CER30	Thermostat with automatic fan speed, dead band, automatic change over for modulating valves (not for ECM models)	•	•	•			•	•	•	•	•		•	•
EDCR	Thermostat with manual or automatic fan speed, dead band, automatic change over for modulating valves - Only for ECM models	Compatible with electrical heaters												
OxU+OC716	Omnibus control + Remote Analogue Plus	Compatible with electrical heaters												
OxU+OC216	Omnibus control + Remote Display console	Compatible with electrical heaters												

Valves (Supplied loose) / Condensate pump / Air sensor / Water sensor (Factory fitted)														
DTH2B2 (2p)	2-way on/off valves for 2-pipe systems, 230V	•	•	•	•	•	•							
DTH2B2 (4p)	2-way on/off valves for 4-pipe systems, 230V								•	•	•	•	•	•
DTH3B2 (2p)	3-way 4-ports on/off valves for 2-pipe systems, 230V	•	•	•	•	•	•							
DTH3B2 (4p)	3-way 4-ports on/off valves for 4-pipe systems, 230V								•	•	•	•	•	•
DTH2B0 (2p)	2-way on/off valves for 2-pipe systems, 24V	•	•	•	•	•	•							
DTH2B0 (4p)	2-way on/off valves for 4-pipe systems, 24V								•	•	•	•	•	•
DTH3B0 (2p)	3-way 4-ports on/off valves for 2-pipe systems, 24V	•	•	•	•	•	•							
DTH3B0 (4p)	3-way 4-ports on/off valves for 4-pipe systems, 24V								•	•	•	•	•	•
DTJ2BM (2p)	2-way modulating valves for 2-pipe systems, 24V	•	•	•	•	•	•							
DTJ2BM (4p)	2-way modulating valves for 4-pipe systems, 24V								•	•	•	•	•	•
DTJ3BM (2p)	3-way 4-ports modulating valves for 2-pipe systems, 24V	•	•	•	•	•	•							
DTJ3BM (4p)	3-way 4-ports modulating valves for 4-pipe systems, 24V								•	•	•	•	•	•
QEC10	230V/24V transformer	•	•	•	•	•	•	•	•	•	•	•	•	•
QEC20	Relay box for parallel connection for 230V actuators (not for ECM models)	•	•	•			•	•	•	•	•		•	•
QEC30	Relay box for parallel connection for 24V actuators (not for ECM models)	•	•	•			•	•	•	•	•		•	•
DT (2p)	Shut-off valves for 2-pipe systems supplied loose	•	•	•	•	•	•							
DT (4p)	Shut-off valves for 4-pipe systems supplied loose								•	•	•	•	•	•
AS	Air sensor	•	•	•	•	•	•	•	•	•	•	•	•	•
WS	Water sensor	Compatible with CEL/CER/EDCR												

- Compatible
- Compatible with conditions
- Not compatible

Dimensions and Weights



YKEY600 and YKEY600-ECM

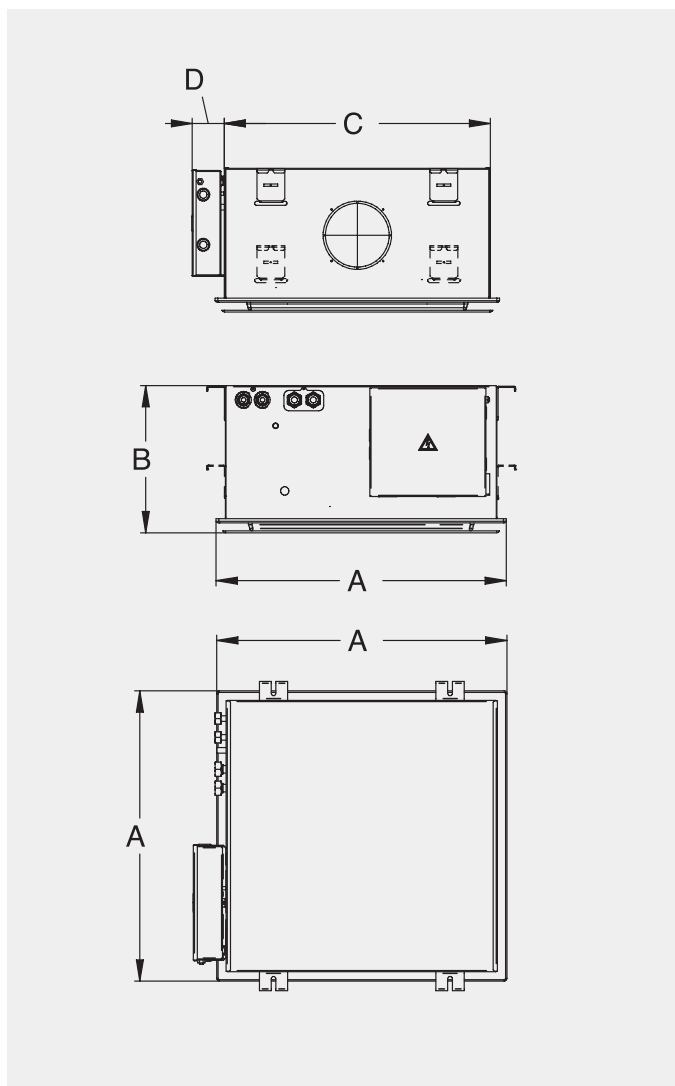

Model YKEY		621-641	622-642	623-643
A	mm	615	615	615
B	mm	328	328	328
C	mm	575	575	575
D	mm	75	75	75
Weight	kg	24 - 25,6	24 - 25,6	24 - 25,6

2 pipes installation		621	622	623
Water inlet		3/4 F	3/4 F	3/4 F
Water outlet		3/4 F	3/4 F	3/4 F

4 pipes installation		641	642	643
Cooling water inlet		3/4 F	3/4 F	3/4 F
Cooling water outlet		3/4 F	3/4 F	3/4 F
Heating water inlet		1/2 F	1/2 F	1/2 F
Heating water outlet		1/2 F	1/2 F	1/2 F

YKEY900 and YKEY900-ECM

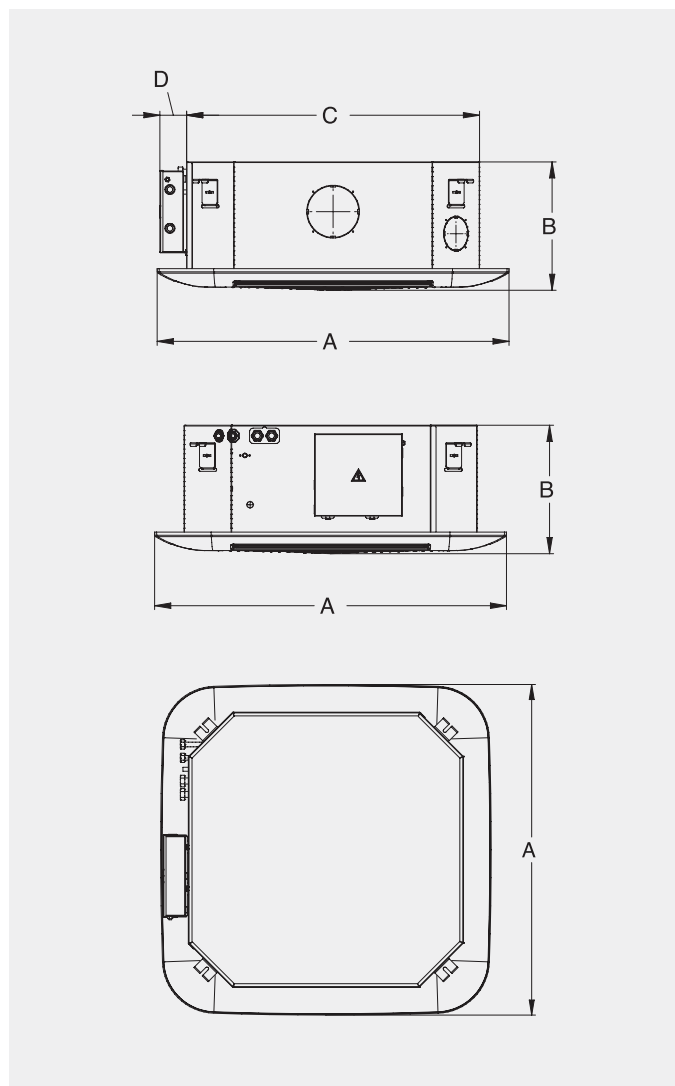

Model YKEY		921-941	922-942
A	mm	985	985
B	mm	360	360
C	mm	820	820
D	mm	75	75
Weight	kg	45	45

2 pipes installation		621	622
Water inlet		3/4 F	3/4 F
Water outlet		3/4 F	3/4 F

4 pipes installation		641	642
Cooling water inlet		3/4 F	3/4 F
Cooling water outlet		3/4 F	3/4 F
Heating water inlet		1/2 F	1/2 F
Heating water outlet		1/2 F	1/2 F

YHK Hydro Cassette

2 and 4 pipe system

A complete range from 1.3 kW to 11 kW

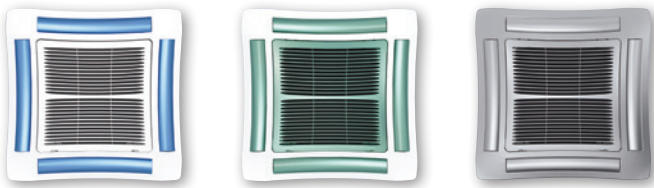

Coloured versions available as an option

YHK Hydro Cassette units are simple and elegant, discreet in their design. High standards of quality and reliability, combined with a wide range of accessories ensure a total solution for all comfort cooling and heating requirements.



Selection software

Wired controls

T9000 Series

• Red Dot Product Design Award Winner 2020

- Touch Screen Display
- 2 or 4 pipes FCU
- 3-speed motors or ECM motors
- 2-wiring/3-wiring on/off valves or proportional valves
- Relay designed for 100,000 switching cycles
- Modbus or BACnet protocols



T7600 Series

- LCD Screen Display
- 2 or 4 pipes FCU
- On/off or proportional
- 3-speed motors or ECM motors
- Modbus RTU



Infrared control



TUC03+ Terminal unit controller

BacNET and N2 Metasys network compatible



Features

- Cooling duty from 1.3 to 11 kW
- 2 and 4 pipes systems in all range
- 2 sizes: 600 x 600 & 800 x 800
- Possible choice between 6 fan speeds
- Condensate pump integrated in all range
- 2/3 way valves fitted or supplied loose in all range
- Coloured versions, possible to change the colour of the grill and the frame
- Possible to select a complete range of controls
- Electric heater fitted as an option for all range (2 pipe only)
- All metal parts insulated to avoid condensations
- EUROVENT Certified

YHK Hydro Cassette

1.3 kW to 11 kW



Technical features

YHK model -2 pipes			20-2	25-2	40-2	50-2	65-2	95-2	110-2
Total cooling capacity [kW]	(1)	max	1.92	2.64	4.26	4.93	6.08	9.39	10.93
		med	1.60	2.31	3.30	3.82	4.86	6.72	8.36
		min	1.25	1.82	2.23	2.91	4.18	5.27	5.27
Sensible cooling capacity [kW]	(1)	max	1.58	2.00	3.11	3.65	4.51	6.36	8.08
		med	1.29	1.72	2.35	2.75	3.53	4.42	6.00
		min	0.99	1.33	1.55	2.05	3.00	3.42	3.67
Water flow in cooling [l/h]	(1)	max	340	461	745	863	1 060	1 636	1 909
		med	280	402	574	667	845	1 166	1 453
		min	219	316	387	506	724	913	913
Pressure drop in cooling [kPa]	(1)	max	10	9.7	20.9	19.7	21.6	26.9	35.6
		med	7	7.6	13.0	12.4	14.3	14.7	21.8
		min	4.5	4.9	6.4	7.5	10.9	9.4	9.4
Heating capacity [kW]	(2)	max	2.24	2.80	4.37	5.15	6.50	9.23	11.72
		med	1.80	2.42	3.28	3.85	5.03	6.40	8.55
		min	1.38	1.85	2.12	2.85	4.27	4.92	5.12
Water flow in heating [l/h] *	(2)	max	340	461	745	863	1 060	1 636	1 909
		med	280	402	574	667	845	1 166	1 453
		min	219	316	387	506	724	913	913
Pressure drop in heating [kPa]	(2)	max	10.7	9.0	10.2	17.8	15.0	22.0	33.8
		med	7.2	6.9	6.1	10.6	9.4	11.4	19.2
		min	4.4	4.3	2.8	6.2	7.0	7.1	7.6
Heating capacity [kW]	(3)	max	4.6	5.7	9.3	10.6	13.1	19.8	23.7
		med	3.7	4.9	7	8.3	10.7	13.4	17.3
		min	2.8	4.2	4.9	6.1	8.6	10.3	10.3
Water flow in heating [l/h]	(3)	max	393	488	795	914	1 130	1 699	2 037
		med	315	422	598	709	874	1 155	1 484
		min	240	360	415	524	741	882	882
Pressure drop in heating [kPa]	(3)	max	9.9	8.4	12.5	16	17.5	20.9	28.9
		med	6.5	6.4	7.6	10	11.3	10.6	16
		min	4	4.8	4	5.9	8.4	6.7	6.7
Water content [l]		0.8	1.4	2.1	2.1	3.0	4.0	4.0	

YHK model -4 pipes			20-4	25-4	40-4	40-6	50-4	50-6	65-4	95-4	95-6	110-4	110-6
Total cooling capacity [kW]	(1)	max	2.27	2.66	3.27	3.86	3.72	4.44	6.26	7.59	8.65	8.72	9.69
		med	1.93	2.33	2.61	3.02	2.96	3.47	4.98	5.60	6.27	6.84	7.75
		min	1.49	1.83	1.83	2.07	2.33	2.69	4.11	4.48	4.95	4.48	4.95
Sensible cooling capacity [kW]	(1)	max	1.84	1.94	2.49	2.88	2.88	3.37	4.61	5.71	6.37	6.67	7.26
		med	1.52	1.68	1.94	2.20	2.23	2.56	3.60	4.09	4.49	5.09	5.64
		min	1.13	1.32	1.32	1.47	1.72	1.94	2.93	3.21	3.49	3.21	3.49
Water flow in cooling [l/h]	(1)	max	401	464	574	664	655	764	1 090	1 326	1 488	1 529	1 667
		med	337	406	456	519	519	597	865	974	1 078	1 192	1 333
		min	260	318	318	355	406	462	712	777	851	777	851
Pressure drop in cooling [kPa]	(1)	max	13.5	8.8	13.4	10.5	17	14.0	18.9	26.9	25.0	34.7	32.0
		med	10	6.9	8.8	7.0	11.2	9.0	12.5	15.4	14.0	22.1	20.0
		min	6	4.6	4.6	4.0	7.2	6.0	8.8	10.3	9.0	10.3	9.0
Heating capacity [kW]	(4)	max	2.66	3.04	3.86	2.91	4.19	3.29	8.02	9.66	7.50	11.16	9.48
		med	2.23	2.66	3.04	2.71	3.33	2.66	6.33	7.15	5.63	8.80	6.78
		min	1.72	2.13	2.13	1.73	2.61	2.14	5.21	5.69	4.59	5.69	4.59
Water flow in heating [l/h] *	(4)	max	261	298	378	250	426	283	783	946	645	1 092	815
		med	219	260	298	233	341	229	618	697	484	858	583
		min	169	209	209	149	267	184	508	555	395	555	395
Pressure drop in heating [kPa]	(4)	max	11.4	8.7	13.3	6.7	15.0	8.4	17.2	24.0	11.8	31.2	15.0
		med	8.3	6.8	8.7	4.6	9.9	5.7	11.2	14.0	7.0	20.3	9.9
		min	5.2	4.6	4.6	2.6	6.4	3.9	7.9	9.3	4.9	9.3	4.9
Cooling water content [l]		1.0	1.4	1.4	1.7	1.4	1.7	3.0	3.0	3.6	3.0	3.6	
Heating water content [l]		0.6	0.7	0.7	0.5	0.7	0.5	1.4	1.4	1.0	1.4	1.1	

Common features			20-4	25-4	40-4	40-6	50-4	50-6	65-4	95-4	95-6	110-4	110-6	
Air flow [m³/h]		max	610	520	710	710	880	880	1 140	1 500	1 500	1 820	1 820	
		med	420	420	500	500	610	610	820	970	970	1 280	1 280	
		min	310	310	320	320	430	430	630	710	710	710	710	
Sound power level [dB(A)]		max	49	45	53	53	59	59	48	53	53	58	58	
		med	40	40	45	45	49	49	40	40	40	48	48	
		min	33	33	33	33	41	41	33	34	34	34	34	
Sound pressure level [dB(A)]	(5)	max	40	36	44	44	50	50	39	44	44	49	49	
		med	31	31	36	36	40	40	31	31	31	39	39	
		min	24	24	24	24	32	32	24	25	25	25	25	
Power supply [V-ph-Hz]														
Power input [W]														
Absorbed current [A]														
Dimensions	Height	mm	275	275	275	275	275	275	303	303	303	303	303	
		Width	mm	575	575	575	575	575	575	820	820	820	820	820
		Depth	mm	575	575	575	575	575	575	820	820	820	820	820

(1) Room temperature 27°C d.b., 19°C w.b. - Water temperature 7/12 °C

(2) Room temperature 20°C - Water temperature: 45/40 °C

(3) Room temperature 20°C - Water inlet temperature: 70/60°C

(4) Room temperature 20°C - Water inlet temperature: 65/55°C

(5) The sound pressure levels are 9 dB(A) lower than the sound power levels and apply to the reverberant field of a 100 m³ room and a reverberation time of 0.5 sec.

* Water flow values as Cooling, accordingly to the EUROVENT standards and UNI ENV 1397



Manufacturer reserves the rights to change specifications without prior notice.

YHK-ECM Inverter Hydro Cassette

2 and 4 pipe system

A complete range from 1.8 kW to 15.1 kW

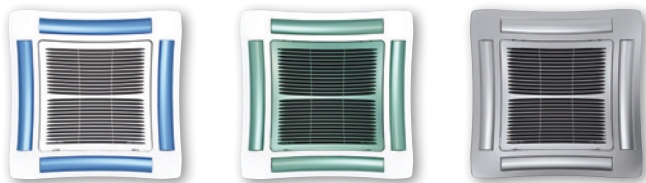

Coloured versions available as an option

YHK ECM water cassette is the result of significant technical and design research focused on providing an avant-garde product in terms of performance, low noise and control flexibility. YHK ECM series uses an innovative brushless electric motor controlled by an inverter card that varies the air flow continuously by means of a 1-10 V signal. The extreme efficiency, also at a low speed, makes it possible to greatly reduce electrical consumption (more than 75% less in comparison to a traditional motor) with absorption values, under normal operating conditions, that are no greater than 10 Watt in the entire range.

Wired controls



T9000 Series

Red Dot Product Design Award Winner 2020

- Touch Screen Display
- 2 or 4 pipes FCU
- 3-speed motors or ECM motors
- 2-wiring/3-wiring on/off valves or proportional valves
- Relay designed for 100,000 switching cycles
- Modbus or BACnet protocols



T7600 Series

- LCD Screen Display
- 2 or 4 pipes FCU
- On/off or proportional
- 3-speed motors or ECM motors
- Modbus RTU



Infrared control



TUC03+ Terminal unit controller

BacNET and N2 Metasys network compatible



Features

- Cooling duty from 1.8 to 15.1 kW
- Different control options for different unit configuration(YHK or YHK-MP):
 - Infrared control available only for YHK-MP configurations
 - Different wired control options available (depending on the unit configuration)
- 2 (-2) & 4 (-4 or -6) pipes systems
- 3 sizes: 600 x 600, 800 x 800 & 870 x 870
- Condensate pump integrated in all range
- 2/3 way valves fitted or supplied loose in all range
- Coloured versions, possible to change the colour of the grid and the frame
- All metal parts insulated to avoid condensations
- Inverter fan motor for a very quiet operation
- Electrical consumption reduced by up to 75%
- Specific range of controllers with master-slave function
- EUROVENT Certified



Selection software

YHK-ECM Inverter Hydro Cassette

1.8 kW to 15.1 kW



ECM the Energy Saving Technology

Brushless motor with inverter managed by dedicated controls. It permits to maintain extremely low electrical absorption and a continuous modulation of the air flow.

Technical features

YHK-ECM model -2 pipes			25-2	40-2	50-2	65-2	95-2	125-2	150-2
Total cooling capacity [kW]	(1)	max 10v	2.73	4.30	4.96	6.30	10.69	12.60	15.13
		med 5v	2.16	3.04	3.85	5.13	7.69	9.43	11.38
		min 1v	1.84	2.24	2.55	4.20	5.28	6.36	7.86
Sensible cooling capacity [kW]	(1)	max	2.07	3.15	3.68	4.69	7.83	9.31	11.41
		med	1.60	2.16	2.79	3.75	5.50	6.77	8.30
		min	1.35	1.57	1.80	3.02	3.68	4.45	5.58
Water flow in cooling [l/h]	(1)	max	473	744	864	1 089	1 848	2167	2602
		med	373	524	666	885	1 328	1622	1957
		min	317	385	441	723	909	1094	1352
Pressure drop in cooling [kPa]	(1)	max	10.1	15.1	19.7	22.7	33.0	22.7	31.8
		med	6.6	9.4	12.4	15.6	18.5	13.4	18.8
		min	4.9	4.6	5.9	10.9	9.4	6.6	9.6
Heating capacity [kW]	(2)	max	2.87	4.36	5.15	6.70	10.56	13.39	16.40
		med	2.22	2.98	3.85	5.30	7.34	9.59	11.86
		min	1.85	2.12	2.46	4.27	4.90	6.18	7.82
Pressure drop in heating [kPa]	(2)	max	9.4	13.2	17.8	21.6	28.1	21.5	31.0
		med	5.9	6.6	10.6	14.2	14.6	11.8	17.3
		min	4.3	3.6	4.7	9.6	7.0	5.4	8.2
Water content [l]			1.4	2.1	2.1	3.0	4.0	4.6	4.6
YHK-ECM model -4 pipes			25-4	40-6	50-6	65-4	95-6	125-4	150-4
Total cooling capacity [kW]	(1)	max	2.75	3.90	4.47	6.48	9.76	11.61	13.59
		med	2.17	2.81	3.51	5.29	7.14	8.86	10.59
		min	1.85	2.09	2.37	4.29	4.97	6.07	7.45
Sensible cooling capacity [kW]	(1)	max	2.06	2.92	3.40	4.80	7.29	8.87	10.68
		med	1.59	2.03	2.60	3.82	5.17	6.53	7.96
		min	1.34	1.49	1.70	3.07	3.51	4.33	5.4
Water flow in cooling [l/h]	(1)	max	476	676	779	1 120	1 697	1997	2337
		med	375	483	608	908	1 233	1524	1821
		min	318	359	409	740	856	1044	1281
Pressure drop in cooling [kPa]	(1)	max	9.5	10.3	13.1	19.8	30.1	22.6	30.4
		med	6.2	5.6	8.4	13.6	17.0	13.8	19.1
		min	4.6	3.3	4.1	9.4	8.8	7.0	10.1
Heating capacity [kW]	(3)	max	3.18	2.91	3.29	8.24	8.33	10.55	12.17
		med	2.51	2.20	2.66	6.65	6.27	8.4	9.8
		min	2.13	1.73	1.92	5.41	4.58	6.01	7.19
Water flow in heating [l/h]	(3)	max	311	288	326	805	818	907	1047
		med	245	217	263	649	616	722	843
		min	209	170	189	528	449	517	618
Pressure drop in heating [kPa]	(3)	max	9.4	6.7	8.4	18.1	14.3	19.9	25.7
		med	6.1	4.1	5.7	12.3	8.6	13.2	17.4
		min	4.6	2.6	3.2	8.5	4.9	7.2	10.0
Common features			25-4	40-6	50-6	65-4	95-6	125-4	150-4
Air flow [m³/h]		max	535	710	880	1 165	1 770	1 905	2480
		med	380	445	610	870	1 130	1 290	1 650
		min	310	310	360	630	710	790	1 025
Sound power level [dB(A)]		max	47	54	60	48	57	58	64
		med	39	43	50	39	47	49	55
		min	33	33	37	33	34	38	44
Sound pressure level [dB(A)]	(4)	max	38	45	51	39	48	49	55
		med	30	34	41	30	38	40	46
		min	24	24	28	24	25	29	35
Power supply [V-ph-Hz]					230 /1 /50				
Power input [W]		max	28.5	44.0	81.0	43.5	126.0	105.0	195.0
Absorbed current [A]		max	0.25	0.40	0.70	0.40	1.10	0.80	1.30
Dimensions		Height mm	275	275	275	303	303	304	304
		Width mm	575	575	575	820	820	869	869
		Depth mm	575	575	575	820	820	869	869

(1) Room temperature 27°C d.b., 19°C w.b. - Water temperature 7/12 °C

(2) Room temperature 20°C - Water temperature: 45/40 °C

(3) Room temperature 20°C - Water inlet temperature: 65/55°C

(4) The sound pressure levels are 9 dB(A) lower than the sound power levels and apply to the reverberant field of a 100 m³ room and a reverberation time of 0.5 sec.

* Water flow values as Cooling, accordingly to the EUROVENT standards and UNI ENV 1397



Condensate pump integrated in all sizes

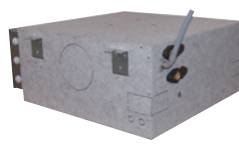

Metal parts insulated to avoid condensation



2 or 3 way valves fitted or supplied loose in all sizes



Outer casing as an option to integrate the water cassette into any environment



Manufacturer reserves the rights to change specifications without prior notice.

Compatibility table / Codes

Model with AC motor (without air diffuser)		YHK 20	YHK 25	YHK 40	YHK 50	YHK 65	YHK 95	YHK 110	-	-
Cassette YHK	2 pipe system	0079100K	0079000K	0079001K	0079002K	0079003K	0079004K	0079005K	-	-
	4 pipe system	0079110K	0079010K	0079011K	0079012K	0079013K	0079014K	0079015K	-	-
Cassette YHK-MP (IR remote control and sensor NOT included)	2 pipe system	0079170K	0079171K	0079172K	0079173K	0079174K	0079175K	0079176K	-	-
	4 pipe system	0079180K	0079181K	0079182K	0079183K	0079184K	0079185K	0079186K	-	-
Cassette YHK-E - with electric resistance	2 pipe system	-	0079060K	0079061K	0079062K	0079063K	0079064K	0079065K	-	-
Cassette YHK-MP-E - with electric resistance	2 pipe system	-	0079191K	0079192K	0079193K	0079194K	0079195K	0079196K	-	-
Cassette YHK-REB with remote electric board	2 pipe system	0079120K	0079020K	0079021K	0079022K	0079023K	0079024K	0079025K	-	-
	4 pipe system	0079130K	0079030K	0079031K	0079032K	0079033K	0079034K	0079035K	-	-
Model with ECM motor (without air diffuser)		-	YHK 25	YHK 40	YHK 50	YHK 65	YHK 95	-	YHK 125	YHK 150
Cassette YHK-ECM - basic model	2 pipe system	-	0079801K	0079802K	0079803K	0079804K	0079805K	-	0079807K	0079808K
	4 pipe system	-	0079811K	0079812K	0079813K	0079814K	0079815K	-	0079817K	0079818K
Cassette YHK-MP-ECM (IR remote control and sensor NOT included)	2 pipe system	-	0079911K	0079912K	0079913K	0079914K	0079915K	-	0079917K ⁽⁶⁾	0079918K ⁽⁶⁾
	4 pipe system	-	0079921K	0079922K	0079923K	0079924K	0079925K	-	0079927K ⁽⁶⁾	0079928K ⁽⁶⁾
Cassette YHK-ECM-E - with electric resistance	2 pipe system	-	0079841K	0079842K	0079843K	0079844K	0079845K	-	0079847K	0079848K
Cassette YHK-ECM-MP-E - with electric resistance	2 pipe system	-	0079901K	0079902K	0079903K	0079904K	0079905K	-	0079907K	0079908K
Mandatory accessories (units cannot work without them)										
Air diffuser - intake grid, frame and louvres in RAL 9003 white colour			AKPA 600			AKPA 800			AKPA 900	
Accessories (factory fitted)										
Valves (220V On/Off)										
3 way valve + mounting kit for 2 pipe models (factory fitted)			9079510			9079511			9079923	
3 way valve + mounting kit for 4 pipe models (factory fitted)			9079512			9079513			9079933	
2 way valve + mounting kit for 2 pipe models (factory fitted)			9079515			9079516			9079921	
2 way valve + mounting kit for 4 pipe models (factory fitted)			9079517			9079518			9079931	
2 way DN 15 balance valve for main coil + connection kit (fact. fitted) *			9079771			9079791			-	
2 way DN 20 balance valve for main coil + connection kit (fact. fitted) *			-			9079792			-	
2 way DN 15 balance valve for additional coil + connection kit (fact. fitted) *			9079773			9079793			-	
Accessories (supplied loose)										
Air diffusers / Panels										
Air diffuser - other colours (*)			Contact Johnson Controls							
Valves (220V On/Off)										
3 way valve + mounting kit for 2 pipe models (not fitted)			9079500			9079501			9079922	
3 way valve + mounting kit for 4 pipe models (not fitted)			9079502			9079503			9079932	
2 way valve + mounting kit for 2 pipe models (not fitted)			9079505			9079506			9079920	
2 way valve + mounting kit for 4 pipe models (not fitted)			9079507			9079508			9079930	
2 way DN 15 balance valve for main coil + connection kit (not fitted) *			9079761			9079781			-	
2 way DN 20 balance valve for main coil + connection kit (not fitted) *			-			9079782			-	
2 way DN 15 balance valve for additional coil + connection kit (not fitted) *			9079763			9079783			-	
Other type of valves			Contact Johnson Controls							
Other Accessories										
Outer casing OCA 600			9079240			-			-	
Outer casing OCA 800			-			9079250			-	
3 way valve + mounting kit for units with outer casing OCA (not fitted)			9079155			9079221			-	
Fresh air duct FAD			6078005			-			-	
Fresh air kit 1 way not suitable for units with outer casing OCA - FAK 600			9079230			-			-	
Fresh air kit 1 way not suitable for units with outer casing OCA - FAK 800			-			9079231			-	
Fresh air kit 1 way not suitable for units with outer casing OCA - FAK 900			-			-			9079235	
MD-600 Metal Grid			9079420			-			-	
MD-800 Metal Grid			-			9079417			-	
CONTROLS for YHK (AC versions)										
Remote three speed control WM-3V (1) (4)						9066642				
Remote three speed control + electronic thermostat and manual S/W switch JWC-T (2)						9066630K				
Automatic speed control with electronic thermostat and S/W switch - JWC-AU (to be used with UPM-AU and UP-AU only) (2) (3)						9066632K				
Automatic remote control with electronic thermostat, S/W switch and liquid crystal display T-MB (to be used with UPM-AU and UP-AU only) (2) (3)						9066331E				
Automatic speed control with electronic thermostat to be mounted in the light wall box WM-503-AC-EC (to be used with UP-503-AC-EC only)						9066686				
Electromechanical thermostat T2T (4) (5)						9060174				
Power unit UPM-AU for JWC-AU and T-MB remote controls, fitted on the unit						9066641				
Power unit UP-AU for JWC-AU and T-MB remote controls, not fitted on the unit						9066640				
Power unit UP-503-AC-EC for WM-503-AC-EC remote control only, not fitted						9066687				
Control accessories for all versions (supplied with separate packaging)										
Low temperature cut-out for control JWC-T						9053048				
Low temperature cut-out for controls JWC-TQR, WM-503 and UP-AU power unit						3021090				
T2 sensor to be used as Change-over for UP-AU power unit						9025310				
Change-over 15-25 for control JWC-TQR						9053049				
Receiver SEL2M						9079109				

* For 4 pipes unit must consider both the valve for main coil than the valve for additional coil.

(1) Not to be used with valves. (2) Can be used with valves and/or low temperature cut-out.

(3) Can be used with Change Over. (4) Not suitable with -E electric heater. (5) Not to be used with low temperature cut-out. (6) Receiver included.

YHVP and YHVP-ECM Hydro High Wall

2 pipe system

A range from 0.61 kW to 3.76 kW



Wired Control T9000 Series

- Red Dot Product Design Award Winner 2020
- Touch Screen Display
- 2 or 4 pipes FCU
- 3-speed motors or ECM motors
- 2-wiring/3-wiring on/off valves or proportional valves
- Relay designed for 100,000 switching cycles
- Modbus or BACnet protocols



Electronic Infrared Control



TUC03+ Terminal unit controller

BacNET and N2 Metasys network compatible



2 Way Valve ON/OFF

with thermoelectric actuator.
Suitable for the connection with Ø 12 mm pipes

Features

- Available with standard AC motors or low energy EC motors
- Wired control or infrared control
- Automatic air sweep (-TA and -MBA variants only)
- Choice of 2 or 3 way valves fitted
- Condensate collection tray
- Air filter included
- Heat exchange coil
- EUROVENT Certified

Wired control (YHVP)

- 4 operation modes (Cool/Heat/Auto/Fan)
- Room temperature and setting
- Fan speed selector (Auto, low, medium and high)

Infrared control (YHVP-TA)

- Wireless
- 5 operation modes (Cool/Heat/Auto/Dry/Fan)
- Sleep Mode
- Room Temperature setting
- Fan speed selection
- Timer
- Air flow direction setting
- LCD display

Note: model shown is -TA variant with automatic air sweep function

YHVP and YHVP-ECM Hydro High Wall

0.61 kW to 3.76 kW



Technical features

Model		YHVP 1	YHVP 2	YHVP 3	YHVP 4	
Total cooling capacity [kW]	(1)	max	1.85	2.16	3	3.76
		med	1.49	1.82	2.3	3.23
		min	1.23	1.42	1.87	2.6
Sensible cooling capacity [kW]	(1)	max	1.44	1.73	2.24	2.93
		med	1.13	1.41	1.67	2.44
		min	0.91	1.06	1.33	1.91
Heating capacity [kW]	(2)	max	2.18	2.62	3.23	4.28
		med	1.68	2.13	2.37	3.53
		min	1.34	1.58	1.89	2.73
Air flow [m³/h]		max	375	480	545	790
		med	270	365	375	610
		min	205	250	280	440
Sound power level [dB(A)]		max	35	39	35	43
		med	41	47	40	51
		min	48	53	51	57
Sound pressure level [dB(A)]	(3)	max	39	44	42	48
		med	32	38	31	42
		min	26	30	26	34
Power supply [V-ph-Hz]		230V/1ph/50Hz				
Power input [W]	max	30	32	46	48	
Absorbed current [A]	max	0.16	0.16	0.23	0.23	
Dimensions	Height	mm	322	322	322	322
	Width	mm	880	880	1185	1185
	Depth	mm	212	212	212	212

(1) Room temperature 27°C d.b., 19°C w.b. - Water temperature 7/12 °C

(2) Room temperature 20°C - Water inlet temperature: 45/40°C.

(3) The sound pressure levels are 9 dB(A) lower than the sound power levels and apply to the reverberant field of a 100 m³ room and a reverberation time of 0.5 sec.

ECM the Energy Saving Technology

Brushless motor with inverter managed by dedicated controls. It permits to maintain extremely low electrical absorption and a continuous modulation of the air flow.

Technical features

Model		YHVP-ECM 0	YHVP-ECM 1	YHVP-ECM 2	YHVP-ECM 3	YHVP-ECM 4	
Total cooling capacity [kW]	(1)	max	1.98	1.98	2.24	3.27	3.72
		med	1.57	1.57	1.86	2.52	3.03
		min	0.61	1.16	1.46	1.82	2.33
Sensible cooling capacity [kW]	(1)	max	1.56	1.56	1.81	2.48	2.89
		med	1.19	1.19	1.45	1.85	2.27
		min	0.47	0.85	1.09	1.3	1.69
Heating capacity [kW]	(2)	max	2.35	2.35	2.74	3.57	4.2
		med	1.78	1.78	2.18	2.63	3.26
		min	0.72	1.26	1.63	1.83	2.4
Air flow [m³/h]		max	415	415	510	620	770
		med	290	290	375	420	550
		min	130	190	260	270	375
Sound power level [dB(A)]		max	52	52	55	53	57
		med	46	46	47	45	49
		min	26	35	40	37	43
Sound pressure level [dB(A)]	(3)	max	43	43	46	44	48
		med	37	37	38	36	40
		min	17	26	31	28	34
Power supply [V-ph-Hz]		230V/1ph/50Hz					
Power input [W]	max	15	15	21	20	30	
Absorbed current [A]	max	0.14	0.14	0.19	0.18	0.26	
Dimensions	Height	mm	322	322	322	322	322
	Width	mm	880	880	880	1185	1185
	Depth	mm	212	212	212	212	212

(1) Room temperature 27°C d.b., 19°C w.b. - Water temperature 7/12 °C

(2) Room temperature 20°C - Water inlet temperature: 45/40°C.

(3) The sound pressure levels are 9 dB(A) lower than the sound power levels and apply to the reverberant field of a 100 m³ room and a reverberation time of 0.5 sec.



Manufacturer reserves the rights to change specifications without prior notice.

Codes high wall fan coil units YHVP				
Unit without IR control without valve	YHVP 1	YHVP 2	YHVP 3	YHVP 4
Unit codes	0025001K	0025002K	0025003K	0025004K
Unit without IR control with 2 way valve	YHVP-2V 1	YHVP-2V 2	YHVP-2V 3	YHVP-2V 4
Unit codes	0025101K	0025102K	0025103K	0025104K
Unit without IR control with 3 way valve	YHVP-3V 1	YHVP-3V 2	YHVP-3V 3	YHVP-3V 4
Unit codes	0025201K	0025202K	0025203K	0025204K
Unit with IR control without valve	YHVP-TA 1	YHVP-TA 2	YHVP-TA 3	YHVP-TA 4
Unit codes	0025071K	0025072K	0025073K	0025074K
Unit with IR control with 2 way valve	YHVP-TA-2V 1	YHVP-TA-2V 2	YHVP-TA-2V 3	YHVP-TA-2V 4
Unit codes	0025171K	0025172K	0025173K	0025174K
Unit with IR control with 3 way valve	YHVP-TA-3V 1	YHVP-TA-3V 2	YHVP-TA-3V 3	YHVP-TA-3V 4
Unit codes	0025271K	0025272K	0025273K	0025274K
Unit with MB board without valve	YHVP-MBA 1	YHVP-MBA 2	YHVP-MBA 3	YHVP-MBA 4
Unit codes	0025061K	0025062K	0025063K	0025064K
Unit with MB board with 2 way valve	YHVP-MBA-2V 1	YHVP-MBA-2V 2	YHVP-MBA-2V 3	YHVP-MBA-2V 4
Unit codes	0025161K	0025162K	0025163K	0025164K
Unit with MB board with 3 way valve	YHVP-MBA-3V 1	YHVP-MBA-3V 2	YHVP-MBA-3V 3	YHVP-MBA-3V 4
Unit codes	0025261K	0025262K	0025263K	0025264K
Unit without IR control without valve with electrical coil	YHVP-E 1	YHVP-E 2	YHVP-E 3	YHVP-E 4
Unit codes	0025031K	0025032K	0025033K	0025034K
Unit without IR control with 2 way valve with electrical coil	YHVP-E-2V 1	YHVP-E-2V 2	YHVP-E-2V 3	YHVP-E-2V 4
Unit codes	0025131K	0025132K	0025133K	0025134K
Unit without IR control with 3 way valve with electrical coil	YHVP-E-3V 1	YHVP-E-3V 2	YHVP-E-3V 3	YHVP-E-3V 4
Unit codes	0025231K	0025232K	0025233K	0025234K
Unit with IR control without valve with electrical coil	YHVP-TA-E 1	YHVP-TA-E 2	YHVP-TA-E 3	YHVP-TA-E 4
Unit codes	0025081K	0025082K	0025083K	0025084K
Unit with IR control with 2 way valve with electrical coil	YHVP-TA-E 2V 1	YHVP-TA-E 2V 2	YHVP-TA-E 2V 3	YHVP-TA-E 2V 4
Unit codes	0025181K	0025182K	0025183K	0025184K
Unit with IR control with 3 way valve with electrical coil	YHVP-TA-E 3V 1	YHVP-TA-E 3V 2	YHVP-TA-E 3V 3	YHVP-TA-E 3V 4
Unit codes	0025281K	0025282K	0025283K	0025284K
Unit with MB board without valve with electrical coil	YHVP-MBA-E 1	YHVP-MBA-E 2	YHVP-MBA-E 3	YHVP-MBA-E 4
Unit codes	0025091K	0025092K	0025093K	0025094K
Unit with MB board with 2 way valve with electrical coil	YHVP-MBA-E-2V 1	YHVP-MBA-E-2V 2	YHVP-MBA-E-2V 3	YHVP-MBA-E-2V 4
Unit codes	0025191K	0025192K	0025193K	0025194K
Unit with MB board with 3 way valve with electrical coil	YHVP-MBA-E-3V 1	YHVP-MBA-E-3V 2	YHVP-MBA-E-3V 3	YHVP-MBA-E-3V 4
Unit codes	0025291K	0025292K	0025293K	0025294K

Controls		
WM-3V Wall control		9066642
JWC-T Wall control		9066630K
JWC-TQR Wall control		9066631K
T2T Wall control		9060174
T-MB2SW Wall control (to be used with MB board only)		9066994ESW
RT03 IR remote control w/receiver RS-RT03-F (to be used with MB board only)		9025301
RT03 infra-red remote control supplied with separate packaging (to be used with MB board only)		3021203
Receiver for RT03 infra-red remote control supplied with separate packaging (to be used with MB board only)		9025300
PSM-DI Multifunction control (to be used with MB board only)		3021293
SEL-CVP Speed switch for controls: JWC-T and JWC-TQR		9025302
Electronic control accessories		
NTC low temperature cut-out thermostat for control JWC-TQR		3021090
TMM low temperature cut-out thermostat for control JWC-T		9053048
Change-Over CH 15-25 for control JWC-TQR		9053049
T2 Sensor (to be used as change-over or low temperature cut-out - for MB only)		9025310
Management system for a network of fan coils with MB electronic board		
Hardware / software supervisory system Net		9079118
Router-S for NET (default) or for BMS systems no provided by YORK		3021290
Relay output board SIOS		3021292

Codes high wall fan coil units YHVP-ECM

Unit without IR control without valve	YHVP-ECM-A 0	YHVP-ECM-A 1	YHVP-ECM-A 2	YHVP-ECM-A 3	YHVP-ECM-A 4
Unit codes	0025560K	0025561K	0025562K	0025563K	0025564K
Unit without IR control with 2 way valve	YHVP-ECM-A-2V 0	YHVP-ECM-A-2V 1	YHVP-ECM-A-2V 2	YHVP-ECM-A-2V 3	YHVP-ECM-A-2V 4
Unit codes	0025660K	0025661K	0025662K	0025663K	0025664K
Unit without IR control with 3 way valve	YHVP-ECM-A-3V 0	YHVP-ECM-A-3V 1	YHVP-ECM-A-3V 2	YHVP-ECM-A-3V 3	YHVP-ECM-A-3V 4
Unit codes	0025760K	0025761K	0025762K	0025763K	0025764K
Unit with IR control without valve	YHVP-ECM-TA 0	YHVP-ECM-TA 1	YHVP-ECM-TA 2	YHVP-ECM-TA 3	YHVP-ECM-TA 4
Unit codes	0025570K	0025571K	0025572K	0025573K	0025574K
Unit with IR control with 2 way valve	YHVP-ECM-TA-2V 0	YHVP-ECM-TA-2V 1	YHVP-ECM-TA-2V 2	YHVP-ECM-TA-2V 3	YHVP-ECM-TA-2V 4
Unit codes	0025670K	0025671K	0025672K	0025673K	0025674K
Unit with IR control with 3 way valve	YHVP-ECM-TA-3V 0	YHVP-ECM-TA-3V 1	YHVP-ECM-TA-3V 2	YHVP-ECM-TA-3V 3	YHVP-ECM-TA-3V 4
Unit codes	0025770K	0025771K	0025772K	0025773K	0025774K
Unit with MB board without valve	YHVP-ECM-MBA 0	YHVP-ECM-MBA 1	YHVP-ECM-MBA 2	YHVP-ECM-MBA 3	YHVP-ECM-MBA 4
Unit codes	025E000K	025E001K	025E002K	025E003K	025E004K
Unit with MB board with 2 way valve	YHVP-ECM-MBA-2V 0	YHVP-ECM-MBA-2V 1	YHVP-ECM-MBA-2V 2	YHVP-ECM-MBA-2V 3	YHVP-ECM-MBA-2V 4
Unit codes	025E020K	025E021K	025E022K	025E023K	025E024K
Unit with MB board with 3 way valve	YHVP-ECM-MBA-3V 0	YHVP-ECM-MBA-3V 1	YHVP-ECM-MBA-3V 2	YHVP-ECM-MBA-3V 3	YHVP-ECM-MBA-3V 4
Unit codes	025E040K	025E041K	025E042K	025E043K	025E044K
Unit without IR control without valve with electrical coil		YHVP-ECM-A-E 1	YHVP-ECM-A-E 2	YHVP-ECM-A-E 3	YHVP-ECM-A-E 4
Unit codes		0025591K	0025592K	0025593K	0025594K
Unit without IR control with 2 way valve with electrical coil		YHVP-ECM-A-E-2V 1	YHVP-ECM-A-E-2V 2	YHVP-ECM-A-E-2V 3	YHVP-ECM-A-E-2V 4
Unit codes		0025691K	0025692K	0025693K	0025694K
Unit without IR control with 3 way valve with electrical coil		YHVP-ECM-A-E-3V 1	YHVP-ECM-A-E-3V 2	YHVP-ECM-A-E-3V 3	YHVP-ECM-A-E-3V 4
Unit codes		0025791K	0025792K	0025793K	0025794K
Unit with IR control without valve with electrical coil		YHVP-ECM-TA-E 1	YHVP-ECM-TA-E 2	YHVP-ECM-TA-E 3	YHVP-ECM-TA-E 4
Unit codes		0025581K	0025582K	0025583K	0025584K
Unit with IR control with 2 way valve with electrical coil		YHVP-ECM-TA-E 2V 1	YHVP-ECM-TA-E 2V 2	YHVP-ECM-TA-E 2V 3	YHVP-ECM-TA-E 2V 4
Unit codes		0025681K	0025682K	0025683K	0025684K
Unit with IR control with 3 way valve with electrical coil		YHVP-ECM-TA-E 3V 1	YHVP-ECM-TA-E 3V 2	YHVP-ECM-TA-E 3V 3	YHVP-ECM-TA-E 3V 4
Unit codes		0025781K	0025782K	0025783K	0025784K
Unit with MB board without valve with electrical coil		YHVP-ECM-MBA-E 1	YHVP-ECM-MBA-E 2	YHVP-ECM-MBA-E 3	YHVP-ECM-MBA-E 4
Unit codes		025E011K	025E012K	025E013K	025E014K
Unit with MB board with 2 way valve with electrical coil		YHVP-ECM-MBA-E-2V 1	YHVP-ECM-MBA-E-2V 2	YHVP-ECM-MBA-E-2V 3	YHVP-ECM-MBA-E-2V 4
Unit codes		025E031K	025E032K	025E033K	025E034K
Unit with MB board with 3 way valve with electrical coil		YHVP-ECM-MBA-E-3V 1	YHVP-ECM-MBA-E-3V 2	YHVP-ECM-MBA-E-3V 3	YHVP-ECM-MBA-E-3V 4
Unit codes		025E051K	025E052K	025E053K	025E054K

Controls

WM-S-ECM continuous fan speed control with S/W switch and liquid crystal display	9066644
T-MB2SW Wall control (to be used with MB board only)	9066994ESW
RT03 infra-red remote control with receiver supplied with separate packaging (to be used with MB board only)	9025301
RT03 infra-red remote control supplied with separate packaging (to be used with MB board only)	3021203
Receiver for RT03 infra-red remote control supplied with separate packaging (to be used with MB board only)	9025300
PSM-DI Multifunction control (to be used with MB board only)	3021293

Electronic control accessories

T2 Sensor (to be used as change-over or low temperature cut-out - for MB only)	9025310
--	---------

Management system for a network of fan coils with MB electronic board

Hardware / software supervisory system Net	9079118
Router-S for NET (default) or for BMS systems no provided by YORK	3021290
Relay output board SIOS	3021292

YORK Close Control units

Maintaining a constant temperature, purity and humidity of air is essential for ensuring a stable environment for critical electronic and computer equipment, this is why there is the need for close control air conditioning. Unlike comfort air conditioning, close control systems must operate constantly 24/7 requiring high reliability and minimal power consumption. Johnson Controls knows that no two close control requirements are the same, this is why the YORK range of custom close control units offers quiet, compact and energy efficient equipment that can be configured to needed requirements.



An extensive offering

- cooling capacities of **up to 160 kW (chilled water) or 94 kW (direct expansion)** with optional free cooling models. Up flow or down flow configuration, either as self-contained packaged units or suitable for connection to remote condensers, are also available
- **optional direct expansion units** fitted with scroll compressors, which have much lower noise and energy consumption than reciprocating compressors
- **R410A** refrigerant units available
- optional **Free Cooling coil** to reduce energy consumption required through use of mechanical cooling
- plug fan with **Electronically Commuted 'EC' fans** option, to allow fully modulating control of airflow
- **low component face velocities**, for a lower total pressure drop and reduced energy consumption
- **minimised dimensions**, enabling one of the market's greatest ratios between sensible cooling capacity and base foot print



YORK YC-P Series Close Control Air Conditioners

A complete range from 8.2 kW up to 160 kW



High energy efficiency and minimum environmental impact

"P" Series air conditioners for close control applications are specialised machines with design and operating features which clearly differentiate them from standard air conditioning units.

The **"P" Series** air conditioners offer very high energy efficiency values in all operating conditions which translates into less CO₂ emissions and particularly low running costs. Though optimised for use in data centers and telephone exchanges, they are equally valid in special applications such as measurement laboratories, TV recording studios, museums, control rooms for electricity power stations and railway junctions and other areas where there are prevalent sensible thermal loads and crowding is negligible.

Their application is also ideal in widely varied industrial sectors: optics, electronics, electromedical equipment, electronic equipment production, musical instrument production etc.

Optimal efficiency

Johnson Controls' **"P" Series** design offers the highest sensible cooling capacity with the minimum footprint possible, which translates into optimal ratio levels of cooling capacity to footprint area. This is an important feature in reducing the space needed by machinery, allowing more room in the space for IT equipment. This advantage is especially important given the progressive increases in capacity required by data centers and other computer applications which, over time, need the addition of extra air conditioners.

Clean efficiency is also ensured by the use of the R410A refrigerant, respectful to the ozone layer.

Features and performance

Brushless DC compressors with inverter technology

- Adapting cooling capacity to the real requirements of the plant is one of the principal conditions of guaranteeing the flexibility required by the most advanced systems. By incorporating **BRUSHLESS DC INVERTER** technology into the compressors it is possible to maximize the performance of the motor, especially at partial loads, the control of which is integrated in the microprocessor.
- The cooling coils of the downflow units (**YC-UP**), both in chilled water and direct expansion versions, have aluminium fins with a hydrophilic treatment that alleviates the risk of condensation and the coil face being covered with water, which would compromise the thermal performance and therefore the air conditioning capacity.
- The use of the environmentally friendly refrigerant HFC R410A does not contribute to the depletion of the ozone layer.
- Thanks to its larger surface area, the filter on the coil allows lower face velocity, which results in lower pressure drop.
- The lower energy consumption of these air conditioners, at the same efficiency, results in a much reduced TEWI (Total Equivalent Warming Impact). The application of EC plug fans reduces both energy consumption and noise levels.

Microprocessor regulation

The Standard digital microprocessor

- allows management of all typical air-conditioning functions: cooling, heating, humidification, dehumidification and filtering
- ensures a regular and optimised operation as to both performance and consumption, providing as well alarm management and self-diagnosis.

Cooling circuit

The air conditioners with direct expansion coil have a frigorific circuit equipped with: scroll compressor with all necessary protective devices, high pressure (manual reset) and low pressure (automatic reset) switches, dehydrating filter with refrigerant sight glass.

YC-OPA, YC-UPA models for pairing with remote condensers, are already equipped with a pressurisation nitrogen charge. The refrigerant charge, and the oil top-up (if required), shall be made by the installer on site.

YC-OPA and **YC-UPA** air conditioners in self-contained packaged format with built-in water-cooled condensers (accessory), are supplied with full refrigerant and oil charge.

Local network management or remote control

YORK YC-P Series air conditioners are capable of standalone operation, local private network with multiple units (up to 12) or fully integrated with Metasys Building Management System from Johnson Controls.

The **YORK YC-P Series** are equipped with an innovative local network monitoring (LAN) system that simplifies management, simplifies maintenance, and optimizes operational safety.

The innovative smart net system allows to revolutionize the local network concept. In fact, taking advantage of the modulation capabilities of the components, this system allows you to actively share the workload between all units in the local network.

Thanks to the breakdown of the workload, it is possible to increase the efficiency of the system by partially requesting the main components such as fans, compressors, electric batteries and humidifiers.

This partitioning translates directly into energy savings of up to 60% compared to redundant networks. In fact, instead of having active units that work 100% of their performance while one (or more) machines are stationary, the smart net system allows the entire unit group to have 50 or 60% of their maximum workload.

In remote applications, the machines can be controlled from remote positions interfacing with common Building Management Protocols such as BacNET, LON and Modbus, either via GSM Modem or TCP/IP Internet Protocol.

For total integration with Johnson Control Metasys Building Management Systems (BMS) the units are equipped with an RS485 card working with BacNET MS/TP protocol.

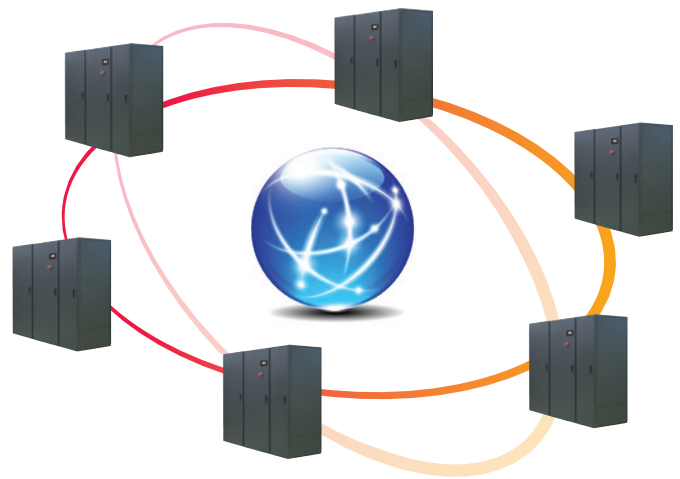

Electronic expansion valve

Electronic expansion valves are one of the most recent pieces of equipment that enable us to improve the energy efficiency at partial loads of direct expansion machines. These valves are installed at the inlet of the evaporator, substituting the traditional thermostatic expansion ones: this allows more precise control of the quantity of refrigerant entering the evaporator, and guarantees good capacity regulation, typically between 100% and 50%. Electronic expansion valves also allows control of the amount of overheated gas at the outlet of the evaporator, thus allowing a significant reduction of the condensation pressure during winter or night-time operation whilst maintaining the evaporation pressure unchanged. Adoption of the electronic expansion valve (optional) guarantees a significant increase of the EER values.

One or two completely independent compressors

Models with "1" as the last digit of the unit model number have a single circuit and a single compressor. Those with "2" as the last digit on the other hand have two completely independent refrigerant circuits and two compressors.

The circuits are fitted with all the safety and regulation devices necessary for efficient and reliable operation.

The evaporator coil can be single or double circuit depending on the number of compressors.

Hydraulic circuit

Air conditioners with chilled water coil, **YC-OPU** and **YC-UPU**, include a finned coil and a three-way motorised valve for water flow regulation. The hydraulic circuit is provided with copper tubes. The coils are optimised for both water with a temperature of 7/12 and for higher ones such as 15/20.

Modulating regulation of the cooling capacity

If a very precise regulation and high response speed are required, a modulating valve is installed as standard. This valve is recommended in case of functioning with a lot of fresh air.

Control Panel

All the units are equipped with a complete control panel with main isolator switch. Magnetothermic switches, contactors, and all necessary protection is provided, as required by legal codes and standards.

The control panel of the units equipped with compressors ("A" as third letter of the identification code) has as standard a phase sequencer, which prevents the compressor from getting damaged when counter running. Also, the control panel has 4 configurable input and output for remote signalling, as well as two terminals for starting up and stopping the unit from remote position.

The condenser fan speed controller (accessory) is installed in the unit and controlled with a 0-10V signal from the microprocessor. All the control parameter are managed by the microprocessor.

The controller is valid for all the AC 230V motors.

EC fans control and power lines available as alternatives.



Modulating controller display and keypad

Large surface filters

The units are equipped with self-extinguishing media class G4 filters. The filters are installed inclined before the cooling coil in order to offer a larger surface and allow lower air crossing speeds, with lower energy consumption.

M5 or F7 filters ON COILS available as accessories.

Design suitable to civil environments

YORK YC-P Series air conditioners have a pleasant and functional design, suitable for installation in civil environments. Their structure consists of aluminium profiles and closing panels hinged on them. Both panels and profiles are epossidic painting RAL 7024.

Two versions are available for up flow units (**YC-OP**): front grille & top air discharge (standard), or blind front panel, suction from the bottom and top discharge (optional).

Fan section

New generation of electronic fans

The ever-growing necessity to save energy has made the use of high-performance EC Plug Fans indispensable in reducing plant costs. The fans installed in **YC-P** close control air conditioners are fitted with **BRUSHLESS EC** (Electronically Commutated) **MOTORS** and a composite-material impeller to maximize performance.

Important advantages obtained as a result include:

- Power drawn by the fans is reduced by over 25% compared to fans using traditional AC technology.
- Power drawn by the fans is reduced by about 15% compared to the previous generation of EC fans.
- Noise levels are reduced by over 5 dB(A) at partial loads.
- Risk to the plant is reduced as the mechanical parts are subjected to less use.

Thanks to integration with the microprocessor, the EC fans can be controlled to:

- Reduce rotation speed and therefore air quantity as the cooling capacity requirement decreases, thus making possible a 50% energy saving, operating at partial loads, compared to a constant velocity system.
- Maintain constant air quantity controlled in real time by differential pressure sensors, optimal control if F7 filters are installed.
- Maintain constant air pressure in the raised floor or in the compartmented areas in order to optimize air distribution avoiding hot spots and guarantee maximum modularity of the plant.

Downflow supply (UPA-UPU models)



Standard version with suction with upper air intake and downflow, with raised floor stand.



Suction with upper air intake and front air outlet with distribution plenum with adjustable grilles.



Suction with upper air intake and front air delivery with grid front panel.

Regulation Options

Johnson Controls provides four different alternatives for the regulation of the airflow of the EC fans depending on the requirements of the installation:

1. Constant fan rotation speed. The available high static pressure is ideal for most applications. The effective air flow depends on the real pressure drop of the aerodynamic system of the installation, however it can be calculated through Johnson Controls computerised selection program.
2. Constant airflow independent of the pressure drop of the system. In order to maintain a constant airflow, an internal sensor guides the microprocessor management system to vary the airflow handled by the fan, depending on the degree of the system. This ensures that insufficient cooling does not occur due to reduced airflow arising from dirty filters.
3. Variable airflow depending on the cooling capacity required by the installation. This is the classic VAV (Variable Air Volume) plant arrangement which responds to increased demand by a proportionate increase in airflow and vice versa. This type of plant offers interesting energy advantages at partial loads, which occur extensively throughout the year, especially at night.
4. Airflow as a function of pressure in the raised floor. This regulation alternative is envisaged for plants with raised floors where the air is distributed under the floor itself. The microprocessor management system maintains constant under-floor pressure. In particular, in very large areas subdivided into multiple local zones with partition dampers driven by individual thermostats, constant regulation of the pressure is necessary to avoid imbalances in the distribution of the air.

Upflow supply (OPA-OPU models)



Standard version with front air intake and upflow air delivery.



Front air intake and front air outlet delivery with distribution plenum with adjustable grilles.



Bottom air intake with raised floor support, blind front panel and upflow air delivery.

Special versions

“Water to air free cooling”: using renewable energy sources

YC-OPA.../FC, YC-UPA.../FC air conditioners are equipped with a “Free cooling” system consisting of an additional chilled-water cooling coil integrated in the aluminium fins of the unit’s direct expansion one, with a three-way modulating valve controlled by the controller. As long as the outside conditions allow the water to respond totally or partially to the cooling request, the controller cuts out or minimises the compressors’ intervention, so reducing substantially the energy consumption.

The water cooled condensers of the frigorific circuit are equipped with a pressostatic system for the regulation of the condensing pressure (flooding valves).

The pumps and the expansion tank are not included in Johnson Control’s supply. The system widely uses the outdoor air—a renewable energy source—in lieu of or in addition to the mechanical cooling.

‘Two Sources’ option utilising excess energy from building HVAC systems

This system consists of the same chilled-water cooling coil as the “Free cooling”, but fed by the building water chiller. A built in frigorific circuit enters in operation in case of lack of chilled water. The result is the maximum security or a remarkable reduction of both consumption and running costs. This system can also use the direct-expansion coil circuit as primary cooling source and, in case of an emergency, the chilled-water coil connected with the tap water network.

The “Two Sources” version is available for units with direct expansion circuit **YC-OPA..../TS, YC-UPA..../TS** as well as units with built in water cooled condenser (accessory) and with double chilled water coil **YC-OPU.../TS, YC-UPU.../TS**: one for district water and the other for tap water or water from a chiller (emergency).

Focus on Free Cooling

High energy saving air conditioning unit

Using renewable energy sources is required to reduce the environmental impact of systems. Our innovative free cooling systems are able to achieve energy savings of over 50% compared to a conventional air conditioner.

Free Cooling from renewable sources

Using **outside air to cool environments** is the primary source of energy savings available in temperate climate areas.

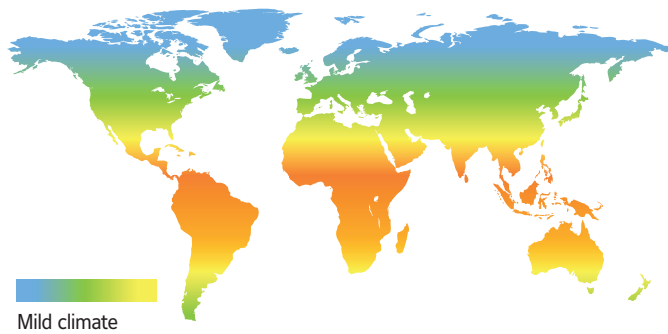

YORK can now offer a range of **FREE COOLING** close control air conditioning units which ensure high energy savings combined with the efficiency and reliability that distinguish this type of product.

Intelligent energy saving

The high number of hours per year in which **FREE COOLING** systems can be used ensures that the air conditioning system energy consumption can be **reduced by over 50%**.

This is reflected in an immediate environmental sustainability increase, thanks to a significant reduction in CO2 emissions, and the system operating costs.

Free Cooling operating hours per year

	Amsterdam	Athens	Belgrade	Berlin	Brussels
Nbr. hours(1)	5,641	4,491	5,105	5,583	5,545
% (2)	64%	51%	58%	64%	63%

	Bucharest	Budapest	Copenhagen	Dublin	Helsinki
Nbr. hours(1)	5,503	5,279	5,861	7,161	5,796
% (2)	63%	60%	67%	82%	71%

	Istanbul	London	Madrid	Milan	Moscow
Nbr. hours(1)	4,779	5,575	4,643	5,281	6,046
% (2)	55%	64%	53%	60%	71%

	Oslo	Paris	Prague	Reykjavik	Vienna
Nbr. hours(1)	6,202	5,187	5,619	7,743	5,651
% (2)	73%	59%	64%	88%	65%

(1) Number of hours with temperatures lower than or equal to 18°C.
 (2) Percentage calculated on a total of 8,760 hours per year.

Indirect Free Cooling

The **indirect FREE COOLING system is characterised by a hybrid unit**, consisting of a primary water circuit and a secondary direct expansion or chilled water circuit. The primary water circuit is connected to a dry cooler that uses outside air – a source of renewable energy – to cool water. The secondary circuit on the other hand exploits the mechanical cooling.

Optimised operating procedures

Depending on the outside air temperatures, three possible operating procedures are possible:

Total Free Cooling

The unit completely operates in **FREE COOLING** without triggering mechanical cooling.

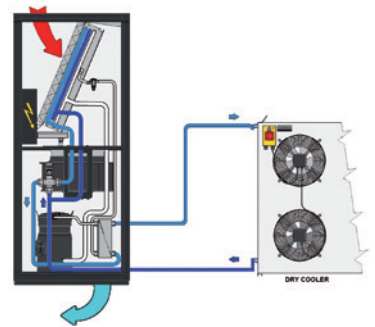

Partial Free Cooling

In addition to operating the **FREE COOLING** circuit, mechanical cooling can be triggered for the time strictly necessary to meet the demand for cooling.

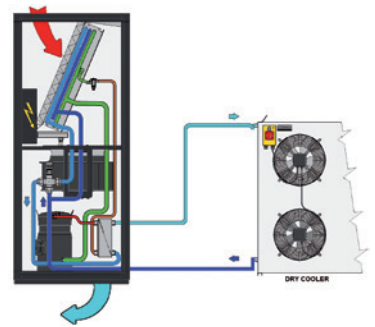

No Free Cooling

Regulation is completely entrusted to mechanical cooling, excluding the **FREE COOLING** circuit.

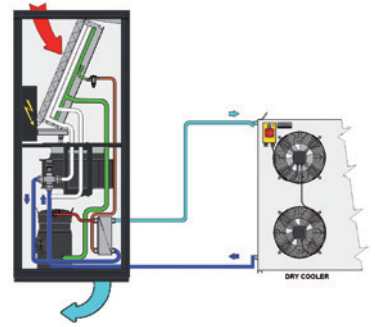

Self-adaptive set-point of the dry cooler

In order to maximise the efficiency of the **FREE COOLING** system, the unit can handle the regulation of the dry cooler coupled to it directly. **Thanks to the self-adaptive set-point function, the fan speed can be regulated so that the water always has a temperature consistent with the outside air conditions.**

This leads to an **increase in the system efficiency**, allowing you to maximise the performance of both the **FREE COOLING** circuit and the direct expansion circuit, ensuring low condensing temperatures. In addition, the fans of the dry cooler will partially operate even with high temperatures, thereby increasing the energy savings of the system.

Focus on Two Sources

Dual circuit system

Some critical applications often require safety devices that prevent discontinuity of operation due to system failure. To allow for such an eventuality, YORK can offer **“Two Source” systems provided with two totally independent cooling sources.**

High operational safety

In an air conditioning system, the main cooling source may be insufficient to guarantee suitable environmental conditions. This may be due to an overload of the system, maintenance, possible seasonal closures or any type of emergency that may arise.

A reduction in the machine cooling capacity can lead to great instability in the system, reducing the ability to control the system thermo-hygrometric conditions.

So as to avoid these problems, specific **TWO SOURCES (TS)** units have been developed providing a second source of cooling, complete with its own control valve and totally independent from the primary one.

A safe, flexible system

The Two Sources system is very flexible and allows three different types of systems:

Chilled water + direct expansion Two Sources

The chilled water primary source of the unit is connected to a building chiller or to District Cooling, whereas the secondary, emergency, and direct expansion one is connected to remote air or in-built water condensers.

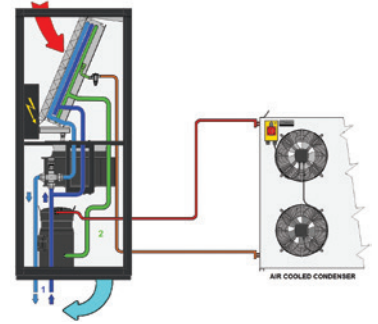

Direct expansion + chilled water Two Sources

The direct expansion primary source of the unit is connected to remote air or in-built water condensers, whereas the secondary, emergency, and water one is connected to a dedicated chiller, to a groundwater/aqueduct water distribution network or to District Cooling.

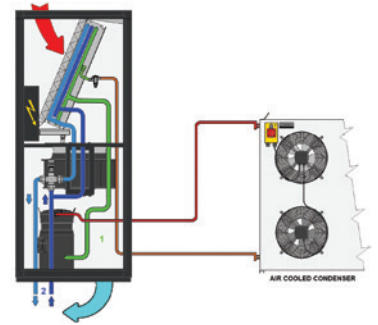

Chilled water + chilled water Two Sources

Both sources of the unit are chilled water coils. The primary one is normally connected to a building chiller or to District Cooling.

The emergency source can be connected to a dedicated chiller or a groundwater/aqueduct water distribution network.

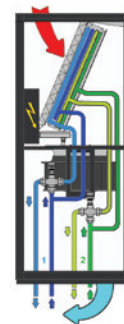

Fittings and accessories

Numerous accessories and options are available for the **"P"** Series air conditioners to personalise the installation depending on the requirements of the plant and its design. Divided by function, they include:

Free cooling or two sources

- Additional Free cooling circuit.
- Additional Two sources circuit.

Alarms

- Water alarm (supplied loose).
- Out-of-range air discharge temperature alarm (standard).
- Smoke/fire alarm terminals (standard).

Water cooled condensers and pressostatic valves

- Welded stainless steel water cooled plate condenser.
- 2 way modulating valve (only if the water condenser is selected).

Sound proofing devices

- Sound damped duct for air suction or discharge (h=550 mm). Allows a reduction of approx 4 dB(A) of the SPL of the unit.

Panels and base

- Blind front panel (OP) and open base for bottom air intake.
- Front panel with grille in the lower part (UP) and closed base.

Plenum

- Plenum (h=550 mm) for air discharge or intake with adjustable grille.

Direct expansion unit cooling capacity regulation

- Electronic expansion valve (standard).
- INVERTER compressor available.

Heating, reheating and humidification

- Single-step or double-step low thermal inertia electrical heating/reheating coil.
- Immersed-electrode modulating humidifier and dehumidification control.
- Humidity sensor for the single control of dehumidification.
- Humidity sensor and control signal for external humidification control not supplied by Johnson Controls.

Boards and sensors

- RS 485 communication board.

Dampers

- Gravity-operated overpressure dampers on the air outlet (OP series).
- Motorised overpressure dampers on the air intake (UP series).

Under bases

- Adjustable under base (OP only).
- Adjustable under base with air deflector (UP only).

Fans and filters

- Electronic EC fans with incorporated inverter for constant rotation speed regulation (standard).
- Electronic EC fans with incorporated inverter for the regulation of air flow in relation to the required cooling capacity (standard).
- Electronic EC fans with incorporated inverter for the regulation of constant pressure in the raised floor.
- M5 or F7 on the COIL.
- Monophase condenser-fan rotation speed variator

Performance at Johnson Controls test conditions*

Technical Characteristics

YC-OPA: direct expansion air conditioners with air cooled or water condensers and up-flow air supply															
Models		71	141	211	251	301	321	322	361	461	422	512	662	852	932
Performances															
Total cooling capacity	kW	8.2	14.7	21.0	26.1	33.2	35.2	33.8	38.1	48.1	43.7	54.8	67.3	84.4	94.4
Sensible cooling capacity	kW	7.9	12.9	21.0	25.2	32.0	35.2	33.8	38.1	46.8	43.7	52.2	66.2	73.7	86.3
EER		3.83	3.40	3.30	3.25	3.17	3.13	3.34	3.57	3.63	3.47	3.45	3.26	3.27	3.64
Airflow	m³/h	2 200	3 200	7 000	7 000	8 700	12 000	12 000	14 000	14 000	14 000	14 000	18 000	17 000	21 000
Sound pressure level	dB(A)	51	59	56	57	60	67	67	58	58	58	59	61	61	61
Dimensions & weight															
Lenght	mm	750	750	860	860	1 410	1 410	1 410	1 750	1 750	1 750	1 750	2 300	2 300	2 640
Depth	mm	601	601	880	880	880	880	880	880	880	880	880	880	880	880
Height	mm	1 990	1 990	1 990	1 990	1 990	1 990	1 990	1 990	1 990	1 990	1 990	1 990	1 990	1 990
Net weight	kg	170	225	280	305	320	385	430	460	470	535	540	685	705	745
Air free cooling		●	●	●	●	●	●	●	●	●	●	●	●	●	●
Water free cooling		○	○	○	○	○	●	○	○	●	○	○	●	●	○
Two Sources		○	○	●	○	●	●	○	○	●	○	●	●	●	●

* Performance refers to: R410A refrigerant; condensing temperature 45°C; incoming air 24°C-45%Rh; water 7/12°C; external static pressure 30 Pa. The declared performance does not take into account the heat generated by fans, which must be added to the system thermal load.
 EER (Energy Efficiency Ratio) = total cooling capacity / compressors power consumption + fans power consumption (air cooled condensers excluded).
 Sound levels at a 2 m distance, in a free field, as per UNI EN ISO 3744:2010.

Technical Characteristics

YC-UPA: direct expansion air conditioners with air cooled or water condensers and down-flow air supply															
Models		71	141	211	251	301	321	322	361	461	422	512	662	852	932
Performances															
Total cooling capacity	kW	8.2	14.7	21.0	26.1	33.2	35.2	33.8	38.1	48.1	43.7	54.8	67.3	84.4	94.4
Sensible cooling capacity	kW	7.9	12.9	21.0	25.2	32.0	35.2	33.8	38.1	46.8	43.7	52.2	66.2	73.7	86.3
EER		3.83	3.40	3.30	3.25	3.17	3.13	3.34	3.57	3.63	3.47	3.45	3.26	3.27	3.64
Airflow	m³/h	2 200	3 200	7 000	7 000	8 700	12 000	12 000	14 000	14 000	14 000	14 000	18 000	17 000	21 000
Sound pressure level	dB(A)	51	59	56	57	60	67	67	58	58	58	59	61	61	61
Dimensions & weight															
Lenght	mm	750	750	860	860	1 410	1 410	1 410	1 750	1 750	1 750	1 750	2 300	2 300	2 640
Depth	mm	601	601	880	880	880	880	880	880	880	880	880	880	880	880
Height	mm	1 990	1 990	1 990	1 990	1 990	1 990	1 990	1 990	1 990	1 990	1 990	1 990	1 990	1 990
Net weight	kg	170	225	280	305	320	385	430	460	470	535	540	685	705	745
Air free cooling		●	●	●	●	●	●	●	●	●	●	●	●	●	●
Water free cooling		○	○	○	○	○	●	○	○	●	○	○	●	●	○
Two Sources		○	○	●	○	●	●	○	○	●	○	●	●	●	●

* Performance refers to: R410A refrigerant; condensing temperature 45°C; incoming air 24°C-45%Rh; water 7/12°C; external static pressure 30 Pa. The declared performance does not take into account the heat generated by fans, which must be added to the system thermal load.
 EER (Energy Efficiency Ratio) = total cooling capacity / compressors power consumption + fans power consumption (air cooled condensers excluded).
 Sound levels at a 2 m distance, in a free field, as per UNI EN ISO 3744:2010.

Performance at JOHNSON CONTROLS test conditions*

Technical Characteristics

YC-OPU: with chilled water coil and up-flow air supply											
Models		10	20	30	50	60	70	80	110	160	220
Performances											
Total cooling capacity	kW	9.9	17.2	30.4	41.0	52.8	63.1	65.4	80.0	110.0	160.0
Sensible cooling capacity	kW	9.3	14.9	27.8	36.2	47.4	54.2	61.8	73.0	99.7	146.0
EER		38.26	29.13	30.00	24.53	22.75	24.17	24.79	24.29	29.33	24.17
Airflow	m ³ /h	2 200	3 200	7 000	8 000	12 000	12 000	16 000	17 000	24 000	36 000
Sound pressure level	dB(A)	51	59	56	60	67	68	61	61	62	65
Dimensions & weight											
Lenght	mm	750	750	860	860	1 410	1 410	1 750	1 750	2 640	3 495
Depth	mm	601	601	880	880	880	880	880	880	880	880
Height	mm	1 990	1 990	1 990	1 990	1 990	1 990	1 990	1 990	1 990	1 990
Net weight	kg	125	150	245	250	270	280	375	410	690	810
Water free cooling		○	○	○	●	○	●	○	●	●	○
Two Sources		○	○	○	●	○	●	○	●	●	○

* Performance refers to: R410A refrigerant; condensing temperature 45°C; incoming air 24°C-45%Rh; water 7/12°C; external static pressure 30 Pa. The declared performance does not take into account the heat generated by fans, which must be added to the system thermal load.
 EER (Energy Efficiency Ratio) = total cooling capacity / compressors power consumption + fans power consumption (air cooled condensers excluded).
 Sound levels at a 2 m distance, in a free field, as per UNI EN ISO 3744:2010.

Technical Characteristics

YC-UPU: with chilled water coil and down-flow air supply											
Models		10	20	30	50	60	70	80	110	160	220
Performances											
Total cooling capacity	kW	9.9	17.2	30.4	41.0	52.8	63.1	65.4	80.0	110.0	160.0
Sensible cooling capacity	kW	9.3	14.9	27.8	36.2	47.4	54.2	61.8	73.0	99.7	146.0
EER		38.26	29.13	30.00	24.53	22.75	24.17	24.79	24.29	29.33	24.17
Airflow	m ³ /h	2 200	3 200	7 000	8 000	12 000	12 000	16 000	17 000	24 000	36 000
Sound pressure level	dB(A)	51	59	56	60	67	68	61	61	62	65
Dimensions & weight											
Lenght	mm	750	750	860	860	1 410	1 410	1 750	1 750	2 640	3 495
Depth	mm	601	601	880	880	880	880	880	880	880	880
Height	mm	1 990	1 990	1 990	1 990	1 990	1 990	1 990	1 990	1 990	1 990
Net weight	kg	125	150	245	250	270	280	375	410	690	810
Water free cooling		○	○	○	●	○	●	○	●	●	○
Two Sources		○	○	○	●	○	●	○	●	●	○

* Performance refers to: R410A refrigerant; condensing temperature 45°C; incoming air 24°C-45%Rh; water 7/12°C; external static pressure 30 Pa. The declared performance does not take into account the heat generated by fans, which must be added to the system thermal load.
 EER (Energy Efficiency Ratio) = total cooling capacity / compressors power consumption + fans power consumption (air cooled condensers excluded).
 Sound levels at a 2 m distance, in a free field, as per UNI EN ISO 3744:2010.

YORK YC-G Series Close Control Air Conditioners

A complete range from 43.3 kW up to 170.2 kW



Applications

"G" Series YORK air conditioners consist of a family of units specially designed to exploit the plant characteristics of the latest generation of large Data Centres.

In the design of air conditioning equipment for large Data Centres, the necessities of cable housing and for the distribution of the enormous quantities of air required to cool the servers have made it necessary to raise the height of the false floor to now reach the current 600–800 millimetres. This creates an ample space below the air conditioner destined to the installation of the plinth. This large space under the raised floor was therefore considered as the housing for the discharge fans. The air conditioners are supplied in two separate sections: the under-base containing the discharge fans to be installed under the floating floor, and the treatment unit with the exchanger coil, filters and the electrical panel.

This large space under the raised floor is used to house the supply air fans. The air conditioners are therefore supplied in two separate sections:

- The treatment unit with enlarged heat exchanger coil, filters and electrical panel.
- The plinth containing the supply air fans, to be installed under the raised floor. The plinth with the fans is supplied to match the height indicated in the order from the customer.

The two sections, shipped separately, are easy to install on-site as they require only electrical connection of the two junction boxes in the air conditioner and the plinth.

Downflow supply



Standard version for perimeter installation inside the Data Centre: the height of the raised floor must be minimum 550 mm.



Version for perimeter installation inside the Data Centre with raised floor height less than 550 mm. In this case, the plinth with fixed height of 550 mm is supplied with lateral closure panels and must be installed above the floor. It is essential to check that the height of the ceiling is sufficient to ensure good air suction.



Version for installation outside the Data Centre, without raised floor, rear air supply. In this case the plinth (fixed height 550 mm) is supplied with side closure panels and rear supply air grilles. Installation of the plenum with rear re-intake system is optional, if there is no ductwork.

Technical Characteristics

YC-UGA: direct expansion air conditioners with air-cooled or water-cooled condensers and downflow air supply				
Models		461	612	932
Total cooling capacity (1)	kW	50.6	63.4	95.6
Sensible cooling capacity (1)	kW	50.4	57	95.6
EER (2)		3.98	3.32	3.8
Airflow	m ³ /h	9 500	10 000	19 000
Sound pressure level (3)	dB(A)	57	58	59
Length	mm	1.490	1 490	2 390
Depth	mm	921	921	921
Height	mm	1 990	1 990	1 990
Net weight	kg	630	680	870

YC-UGU: chilled water coil air conditioners with downflow air supply					
Models		70	150	230	300
Total cooling capacity (1)	kW	43.3	85.1	123	170.2
Sensible cooling capacity (1)	kW	43.3	85.1	123	170.2
EER (2)		31.15	32.48	34.55	39.13
Airflow	m ³ /h	9 500	19 000	28 500	38 000
Sound pressure level (3)	dB(A)	57	59	61	60
Length	mm	1 320	2 220	3 120	4 020
Depth	mm	921	921	921	921
Height	mm	1 990	1 990	1 990	1 990
Net weight	kg	610	750	930	1 250

(1) Performance refers to: R410A refrigerant; condensing temperature 45°C; incoming air 32°C-30%Rh; water 15/20°C; external static pressure 30 Pa.

The declared performance does not take into account the heat generated by fans, which must be added to the system thermal load.

(2) EER (Energy Efficiency Ratio) = total cooling capacity / compressors power consumption + fans power consumption (air cooled condensers excluded).

(3) Sound levels at a 2 m distance, in a free field, as per UNI EN ISO 3744:2010.



Manufacturer reserves the rights to change specifications without prior notice.

YORK YC-R Series Close Control Air Conditioners

A complete range from 21.9 kW up to 36 kW



Applications

“R” Series YORK air conditioners consist of a family of units specially designed and constructed to have the same dimensions as the racks.

In the design of air conditioning plant for large Data Centres, the reduction of energy consumption is of ever increasing importance. For this reason the following concepts have become consolidated international standard practice:

- The racks containing the servers are more often positioned according to the “hot corridor aisle” and “cold corridor/aisle” layout.
- The working air temperatures are now allowed to go up to 30–35°C in the hot corridor and 20–25°C in the cold one, with very low humidity (never above 30%). Consequently, also the water temperature is allowed to rise up to 20–28°C, using the Free Cooling system to the best effect.
- Server capacities keep going up while their dimensions keep going down. This means that more servers can be installed in a rack so that some of these racks, remaining empty, can be removed. At the same time the heat dissipated rises and more capacity is required from the air conditioners.
- The servers work day and night albeit with a night time reduction of their capacity. It is therefore essential for the air conditioning installation to have an efficient modulating cooling capacity control and to be designed for minimum energy consumption and minimum environmental impact.

Horizontal supply



Version for in-row installation with front and lateral air supply.

Technical Characteristics

YC-HRA: direct expansion air conditioners with air-cooled or water-cooled condensers and horizontal air supply

Models		231	361
Total cooling capacity (1)	kW	21.9	35.1
Sensible cooling capacity (1)	kW	21.8	33.9
EER (2)		3.52	3.75
Airflow	m ³ /h	6 000	6 800
Sound pressure level (3)	dB(A)	52	54
Length	mm	600	600
Depth	mm	1 222	1 222
Height	mm	1 985	1 985
Net weight	kg	215	215
Free Cooling		●	○
Two Sources		●	○

YC-HRU: chilled water coil air conditioners with horizontal air supply

Models		20	40
Total cooling capacity (1)	kW	24.1	36
Sensible cooling capacity (1)	kW	24.1	36
EER (2)		18.12	29
Airflow	m ³ /h	6 000	9 000
Sound pressure level (3)	dB(A)	56	61
Length	mm	300	600
Depth	mm	1 200	1 222
Height	mm	1 970	1 985
Net weight	kg	120	190
Free Cooling		○	●
Two Sources		○	●

(1) Performance refers to: R410A refrigerant; condensing temperature 45°C; incoming air 32°C-30%Rh; water 15/20°C; external static pressure 30 Pa.

The declared performance does not take into account the heat generated by fans, which must be added to the system thermal load.

(2) EER (Energy Efficiency Ratio) = total cooling capacity / compressors power consumption + fans power consumption (air cooled condensers excluded).

(3) Sound levels at a 2 m distance, in a free field, as per UNI EN ISO 3744:2010.



Manufacturer reserves the rights to change specifications without prior notice.

YORK YC-H Series Close Control Air Conditioners

A complete range from 32.3 kW up to 141 kW



The **YORK YC-H Series** units, in their standard configuration, are complete with all adjustment components (heat recovery system, cooling, pre- and post-heating, humidification and dehumidification), sized for the treatment of full fresh air or with partial recirculation.

A flexible configuration and a high number of accessories guarantee the use of **YC-H Series** units for applications such as: operating theatres, laboratories and clean rooms, image diagnosis rooms, wards and intensive care.

Features

- Compatibility with European Regulation 1253/2014/EU ErP NRVU 2018
- TÜV certification according to DIN1946/4
- EC fans
- R410A scroll compressors with inverter-controlled brushless DC motor
- RS485 Modbus RTU slave board for interface with BMS (Building Management System)
- Single block painted structure with epoxy resins 60µ RAL 9010
- Panels with thermal and acoustic insulation system using 50mm thick self-extinguishing material, equipped with handles with safety closing system and inspection window
- Motorised dampers on external air intake and gravitational ones on exhaust
- High levels of static pressure available based on the need for installing absolute terminal filters
- Section for air suction from the rooms, partial recycle or total exhaust to the outside
- Static or dynamic management of overpressure or depression in the controlled room compared to a reference environment
- Room emergency negative pressure activation system
- Three air filtration stages (external, supply and return). Tight seal filter and differential pressure switch supports for each filter
- Easy to sanitise and sterilise. No risk for Legionella Pneumophila
- Condensate drains of the independent sections and fitted with syphon that can be inspected
- Electrical panel complete with adjustment and safety devices
- Control microprocessor with graphical display
- Hydronic heat recovery system with inverter-controlled pump with thermal by-pass function
- Electronic expansion valves EEV
- Modulating 3-way valves
- Anti-freeze safety system
- Submerged electrode humidifier
- Nighttime machine standby and load reduction system for UPS power supply

Technical Characteristics

YC-H Models		2500	3800	4800	7000	9200	11200
Chilled water performance (YC-OHU)							
Total cooling capacity	(1) kW	32.3	-	64.1	104.5	117.2	141.0
Direct expansion performance (YC-OHA)							
Water cooling capacity	(2) kW	27.1	45.7	53.3	86.6	110.7	118.8
Air circulation							
Air flow	(3) m ³ /h	2500	3800	4800	7000	9200	11200
Sound quality							
Sound pressure level	(4) dB(A)	58	59	61	61	63	65
Dimensions and weights							
Length	mm	2600	2800	2800	2800	2800	2800
Depth	mm	930	1180	1180	1470	1820	2100
Height	mm	1740	2080	2080	2080	2080	2080
Net weight	kg	900	1200	1250	1600	1800	2000

- (1) The performances, declared according to UNI EN 14511-1:2018, do not consider the heat generated by the fans which must be added to the thermal load of the system. The performances refer to the following conditions: incoming air: 35°C-40% UR; heat recovery with glycol at 27%; water: 7/12°C.
- (2) The performances, declared according to UNI EN 14511-1:2018, do not consider the heat generated by the fans which must be added to the thermal load of the system. The performances refer to the following conditions: incoming air: 35°C-40% UR; heat recovery with glycol at 27%; R410A refrigerant; condensation temperature: 45°C.
- (3) External static pressure: 800 Pa
- (4) The sound pressure levels at a distance of 2 m, 1.5 m height, free field and with ducted supply outlets, declared according to UNI EN ISO 3744:2010.

Air conditioning plant for surgical room with unidirectional air filtration ceiling

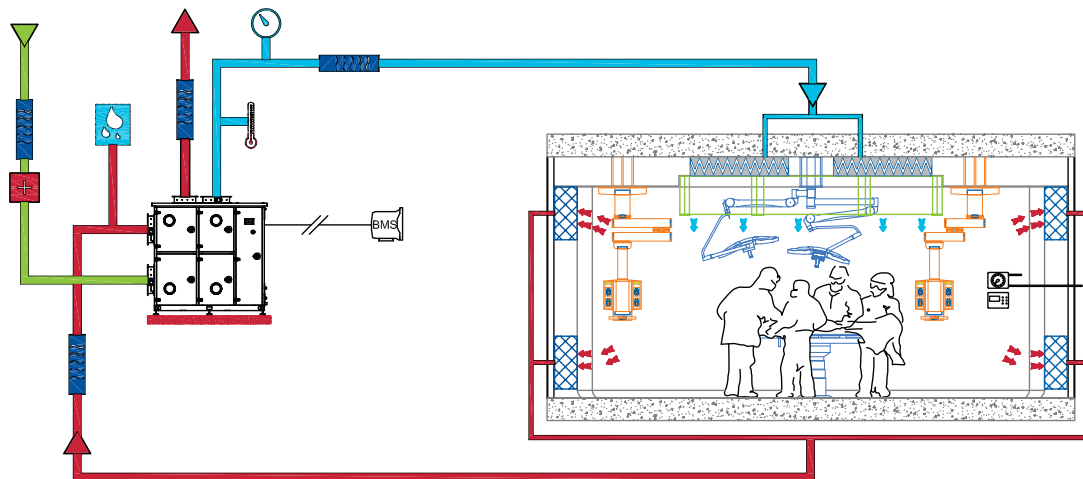

Accessories

- Rectangular silencers for duct installation designed for hospital environments and clean rooms
- Motorised dampers on all outlets
- Motorised air recirculation damper
- Execution for external installation
- Modulating two-way valves instead of three-way
- Booster pump with anti-freeze function, for low outdoor temperatures
- Direct expansion post-cooling circuit for cardiac surgery
- System for regulating and distributing network steam
- Constant pressure control in supply and return ducts
- Remote or duct installation room temperature and humidity probes
- Supply humidity probe
- Display system showing the percentage of filter clogging
- User terminal for remote installation
- LED lighting inside the compartments and electrical panel
- Power supply line with speed regulator for remote condenser
- Condensation regulation with 0-10V signal for remote condenser with EC fans

NEW EUROPEAN REGULATION ON NON-RESIDENTIAL VENTILATION ErP NRvU - Ecodesign Directive - European Regulation 1253/2014/EU

Within the legislative framework of the European Community ErP (Energy-related Products) 2009/125/EC, also called Ecodesign Directive, Regulation 1253/2014/EU came into force on 26 November 2014. This regulation concerns non-residential ventilation units (NRvU) and establishes the specific ecodesign requirements to be met before placing them on the market or putting them into service.



Manufacturer reserves the rights to change specifications without prior notice.

YC-W Series Fan Wall Units

A range from 100 kW to 350 kW



Features

YORK Fan Wall Air Conditioners provide sensible cooling for the heat generated by the equipment installed inside the racks. The W series have constructional and operating characteristics suitable for meet the design criteria of last-generation large Data Centers, when a technical service corridor is present.

The unit are designed to take the hot air generated by the servers coming from the hot aisle and blow the cooled air directly into the Data Hall. This type of chilled water unit is specifically designed to be modular and customizable, with several tailor-made configurations available, to meet the architecture of modern Data Centers. Its minimized footprint and the installation in a technical aisle allow the W series to not occupy any critical space, maximizing the Data Hall capacity. Due to low air speed ventilation cooling system optimized for these applications, YORK W Series ensure a very high EER and contribute to reach very low mechanical PUE values.

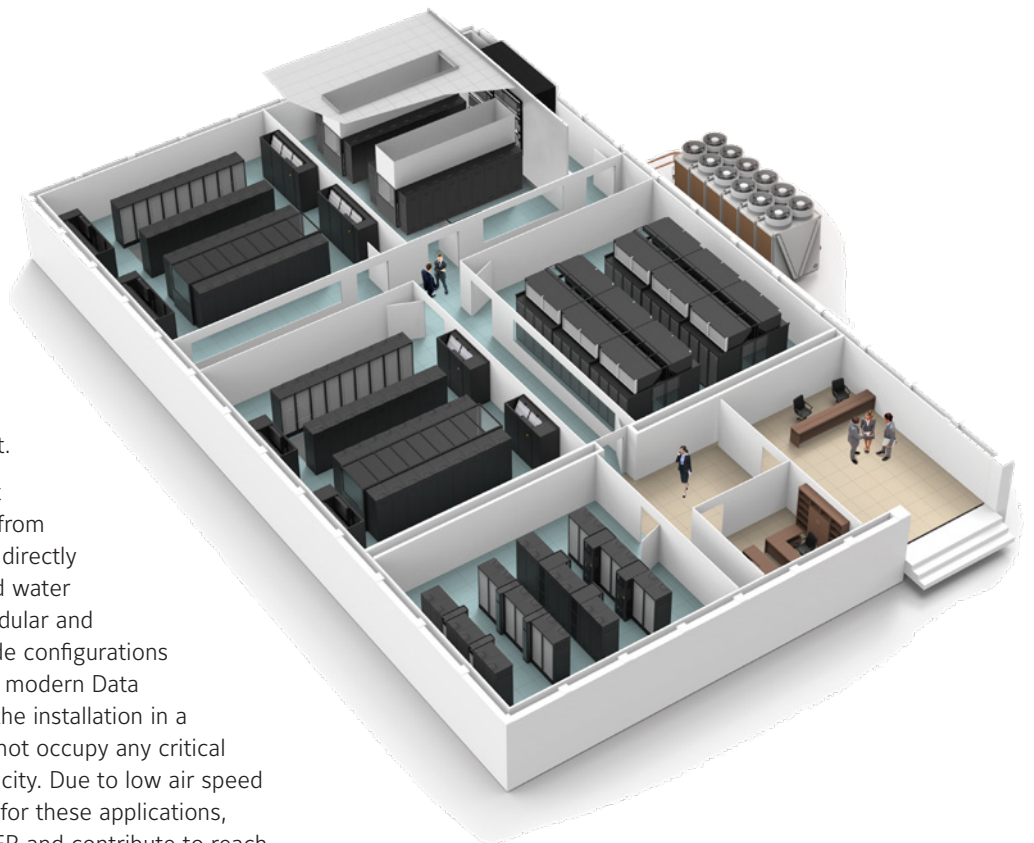

YC-W Series

100 kW to 350 kW



Technical Characteristics

Model	YC-W	
Cooling capacity range	kW	100 - 350
Air volume range	mc/h	35 000 - 85 000
Refrigerant		Water
Fan type		EC Modbus control
Filter		G4
Controller		RS485 / Modbus® card
BMS connection		BACnet MS/TP or PI card
Height	mm	2 900
Length	mm	4 200
Net weight	kg	215
Options		ATS
		Ultracapacitor
		Water leak detector

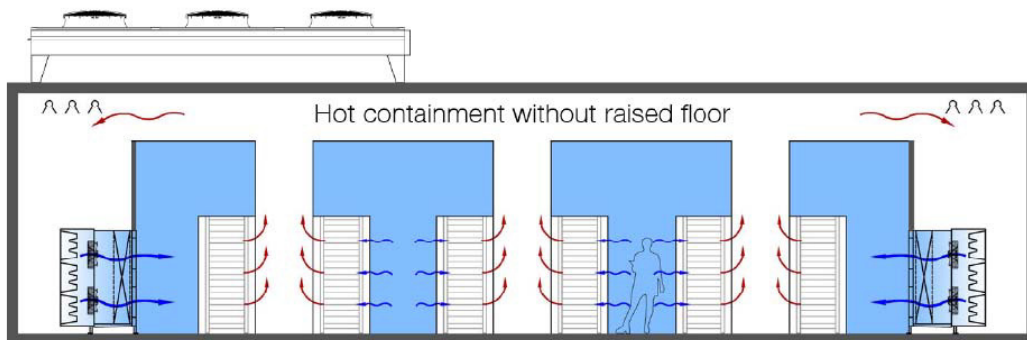
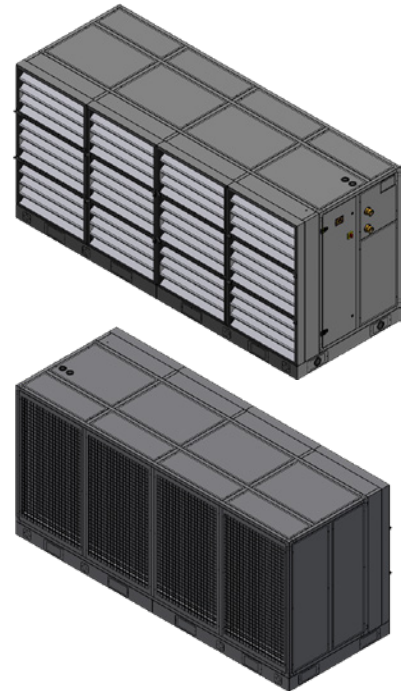
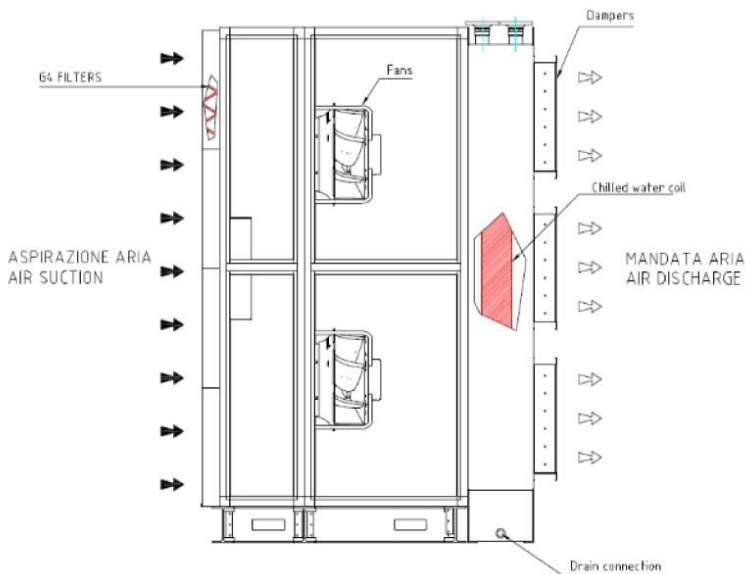

Manufacturer reserves the rights to change specifications without prior notice.

Factory fitted controls

As the need for ever more connected buildings and controls grows, and the Internet of Things approaches, factory fitted controls from Johnson Controls offers control solutions that reduce cost, enhance quality and optimise commissioning time.

Once on site, the equipment can be started immediately. Commissioning time is dramatically reduced, allowing to better control the project costs through simplifying equipment installation and commissioning.

Quality is ensured through application and testing to European Installation regulations at the factory. Pre-installed software is configured to deliver air at the specified volume, temperature and humidity.

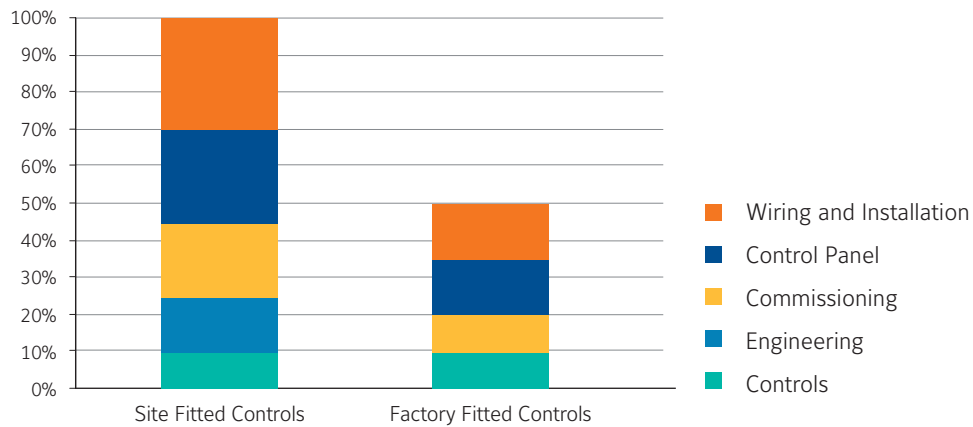

Plug-and-Play Experience



Factory fitted controls for YORK Air Handling units

The Air Handling Unit arrives on site **ready to connect** to the site network, and final commissioning is simplified through the unit's keypad and display.

Panel Power wiring, controls wiring, Variable Speed Drive, pre-engineered controller and required peripheral devices are all supplied, factory fitted and tested.



Factory fitted controls for YORK Fan Coil units

YORK Fan Coil Units are available with factory fitted controls and numerous options for controllers and valves **to allow reduced installation time on site.**

A range of standard configurable or fully programmable controllers are offered along with a choice of Industry standard protocols. Valve requirements can also be met with a wide range of modulating and on/off actuators and isolation valves available and factory fitted.



Factory fitted controls for YORK Rooftop and Close Control units

Factory fitted controls' solution enable, to **dramatically reduce on-site commissioning costs.** Both are delivered to site with pre-installed controls, factory tested and ready to apply the power.

YORK Standard Control panel

Furthermore, Variable Speed Drives give **extra efficiency communicating** with the Johnson controller using industry standard protocols and providing for seamless communications with existing BAS control systems.

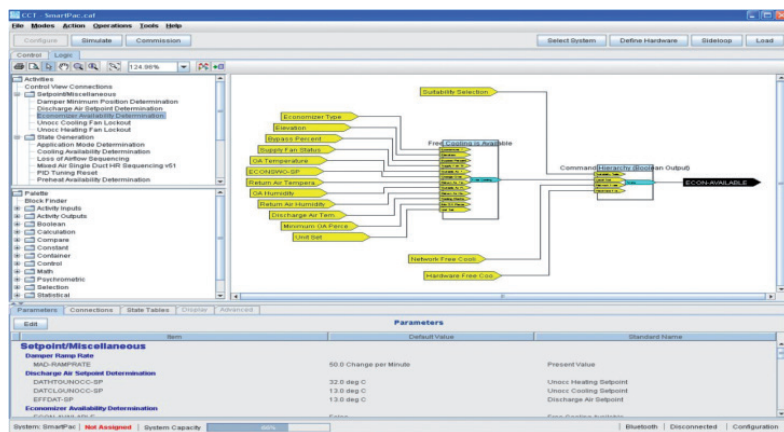

Advanced Control Made Easy

Comfort, productivity and up to half of the energy used in your building – these are all factors affected by how your chiller operates and how it interacts with other components in your HVAC&R system. To help maximize efficiency and keep you in control, some of our YORK Airside equipment is available with integrated SMART EQUIPMENT. This technology allows the equipment to connect seamlessly to building controls like our world-class Verasys system, where smart-enabled equipment can self-identify and interoperate. Verasys provides a truly plug-and-play experience, with no programming or commissioning tools required. Remote access over a secure internet connection and alarm notifications via email or text are

possible through Verasys. The user-friendly graphical interface provides easy access to critical equipment and facility information to help minimize the risk of unplanned downtime and costly repairs. Verasys also provides enhanced energy efficiency control, allowing a facility owner to potentially move from an average Class D efficiency classification to a Class A efficiency classification according to the EN 15232 standard. The key to this efficiency is demand control, where Verasys routes the energy requirements of a room or space to the heating and cooling equipment – matching the demand-side and the supply-side to provide greater overall energy efficiency.



Comprehensive Solutions

Verasys Configurable building controls system for smarter buildings

EasyIO®

Metasys® Upgrades, Migrations and Subscriptions (MUMS)

Tailored Service Solutions for HVAC



Configurable building controls system for smarter buildings

For Light Commercial Building Controls

Enterprises have more options to reduce costs and increase control of HVAC, refrigeration and lighting equipment. Verasys is a new plug-and-play control system with less complexity and more capabilities. It streamlines installation, commissioning, and servicing, and provides access to critical data – when you need it and where you need it – to help facilities perform at peak levels.

Verasys provides a simple user experience with configurable controllers (without tools), creating the first plug-and-play experience integrating HVACR equipment and controls for a certified system that's compliant for energy efficient operations.



Making buildings smarter by optimizing equipment.

The Verasys control system leverages smart equipment technology from any manufacturer. Verasys is a straightforward, easy way to control and optimize single-site and multi-site enterprises. All mechanical equipment seamlessly connect to it and self-identify without requiring any special programming tools. As a result, you can take advantage of a new level of insight into building operations, and provide facilities that better serve occupants.

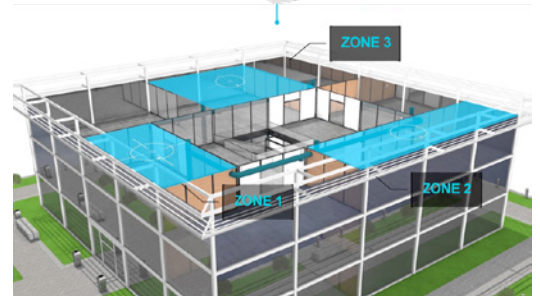

Smart, integrated control. Simplified and supported.

Verasys gives users remote access over a secure internet connection. Plus, optional fault detection and diagnostics deliver alarm notifications immediately via email or text, and user-friendly graphics provide easy access to critical facility information to help minimize the risk of unplanned downtime and costly repairs. You can take advantage of predictive technologies solutions that deliver the quality and value your enterprise requires.

Enhanced energy efficient control for smaller commercial buildings allow for an even higher energy class according to the EN15232. The advantage is that a facility owner can move from an average class D to a class A. The key to this efficiency is demand control, where the consumer spaces/rooms send the energy demands signals/requirements to the heating/cooling equipment. Matching the demand side and the supply side guarantees an energy efficient system overall.

Whether it's one site, or one thousand, Verasys provides an advanced level of control flexibility, including scheduling, alarming, setpoints, custom trending, and more. It communicates using BACnet® MSTP, so Verasys is expandable to any BACnet® compliant system. And it works with third-party package equipment for greater application flexibility and to protect existing investments.

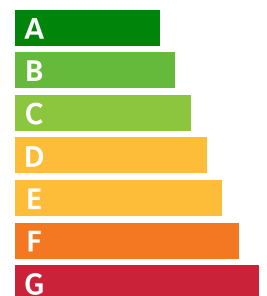

Leveraging Smart Equipment from Johnson Controls.

Smart Equipment from Johnson Controls identifies embedded equipment that has advanced technology and smarts already embedded. Verasys takes full advantage of our Smart Equipment technology. It provides real-time performance data. No programming or commissioning tools. No engineering required. Just plug-and-play.

The primary benefit of Smart Equipment is that it already has controls embedded by the manufacturer. This means it can connect seamlessly to controls systems like Verasys. It uses on-board controls to support data analytics, including fault detection, to support proactive maintenance and minimize downtime. Plus, control products/devices that are capable of controlling equipment without a supervisory controller provide a user interface experience. This allows it to self-discover and/or communicate with other Smart Equipment. In short, Smart Equipment helps maximize control for greater efficiency, extended equipment life and reduced operating costs.

To see how you can take advantage of Smart Equipment, visit www.getsmartequipment.com.

Built-in comfort and efficiency.

Verasys helps enable a smarter building which means more comfort, productivity and efficiency. Verasys connects you to data streams from smart controls in rooftop units, chillers, heat pumps, fan coils, zone dampers, refrigeration systems, lighting panels and more. Data can be accessed anywhere, at any time, from any mobile device. This unprecedented, real-time access to critical information ensures energy efficiency and lower operating costs throughout the building's lifecycle so you can identify issues before they result in unplanned downtime. This extends equipment life.

You also have the opportunity to save operating costs and simplify access to smart technology with Verasys, a complete buildings controls system that provides near real-time analysis of facility health and performance for optimal uptime. This includes access to a technologically advanced family of controllers which are configurable (no programming or tools needed), and access to a library with a vast array of applications that provides versatility and expandability.

A smarter way to transform your business.

Verasys provides the means, capabilities and reliable products to deliver leading-edge, end-to-end control technology to building owners. You get the best value and optimized building environments that support enterprise needs to increase productivity, efficiency, and maximize energy and cost savings.

Plug and play control system to manage smart buildings.

In a single building, or across an entire enterprise, Verasys offers a new kind of plug-and-play controls solution. Through an advanced yet intuitive user interface, it delivers a higher level of building control intelligence that optimizes building ecosystems, resulting in a building that better serves its occupants.

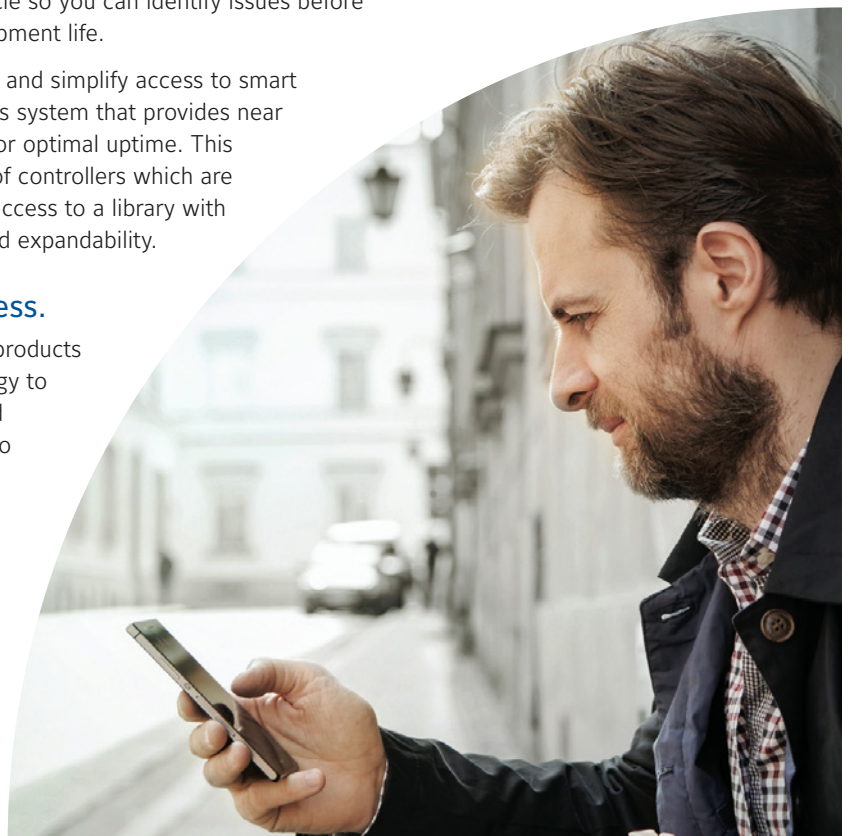

EasyIO®



Powerfully open. Completely customizable.

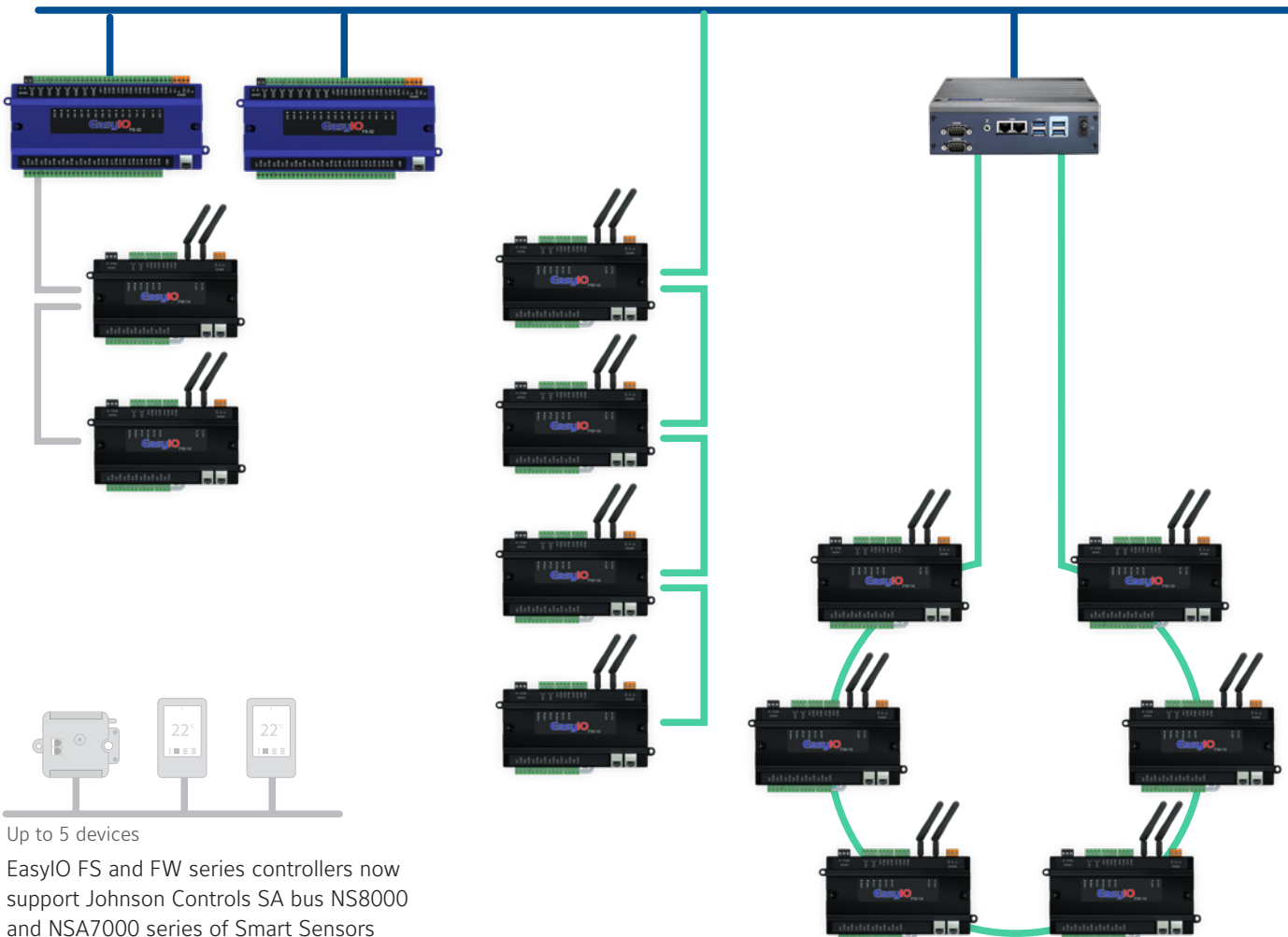



EasyIO Programmable Controllers

EasyIO brings building automation into the era of IoT with the ability to expand integration opportunities and provide data from every level. From the edge to the cloud, EasyIO provides you the flexibility to choose the architecture that best suits your building management needs.



FX80 Supervisory Engine

A web-based supervisory-class FX engine in the Facility Explorer product family. The FX80 engine manages networks of field controllers using open communication protocols.



FX14 Supervisory Server Software

The FX Server is a software package that resides and runs on a third-party computer hardware platform. The FX Server connects to IP-based field controllers, or one or more FX supervisory controllers, and provides extra features to expand their capabilities.



FX Explorer - FX server (FX14)

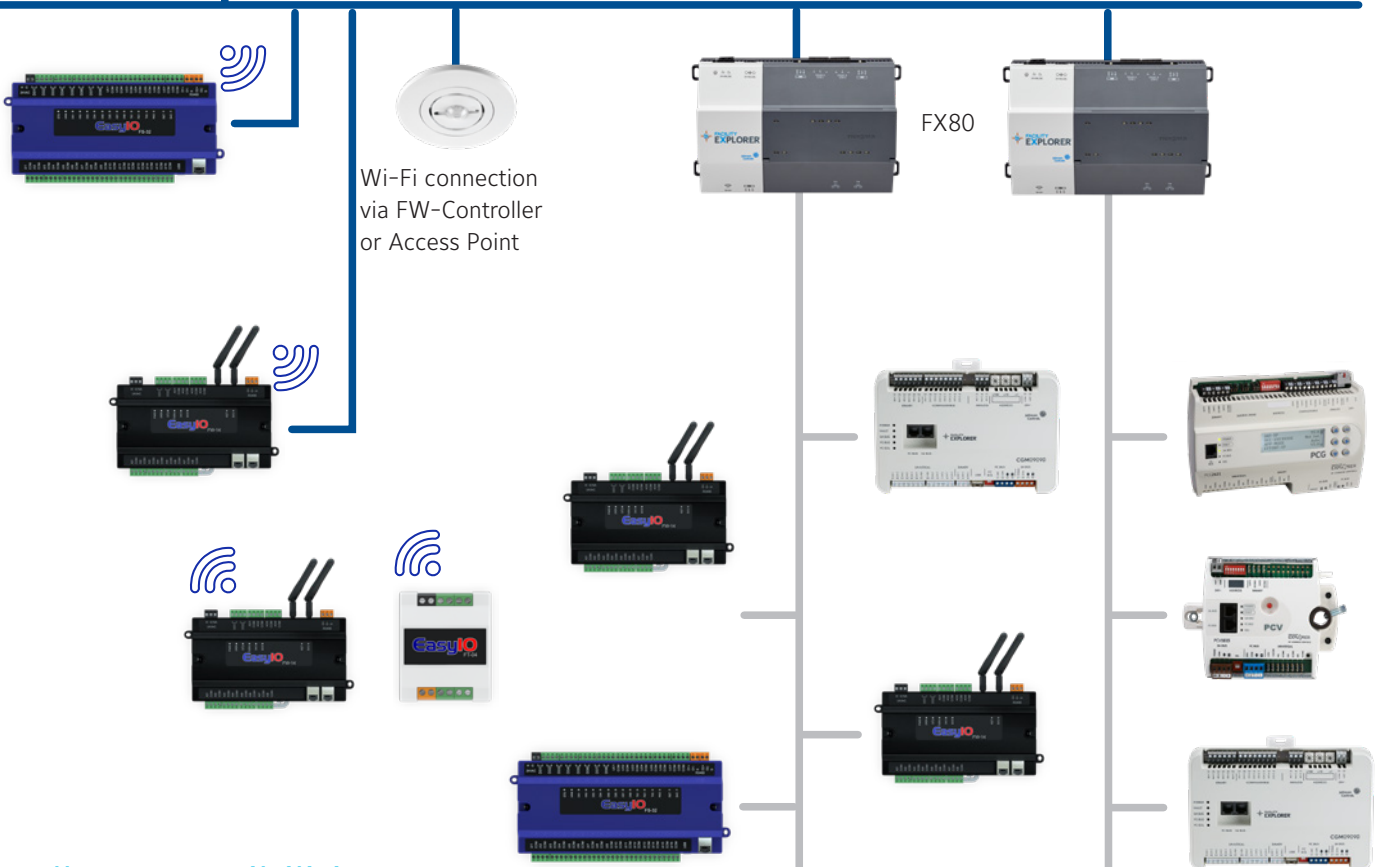

Endless possibilities

From small to enterprise sites, Johnson Controls enables you.



Metasys® Upgrades, Migrations and Subscriptions (MUMS)

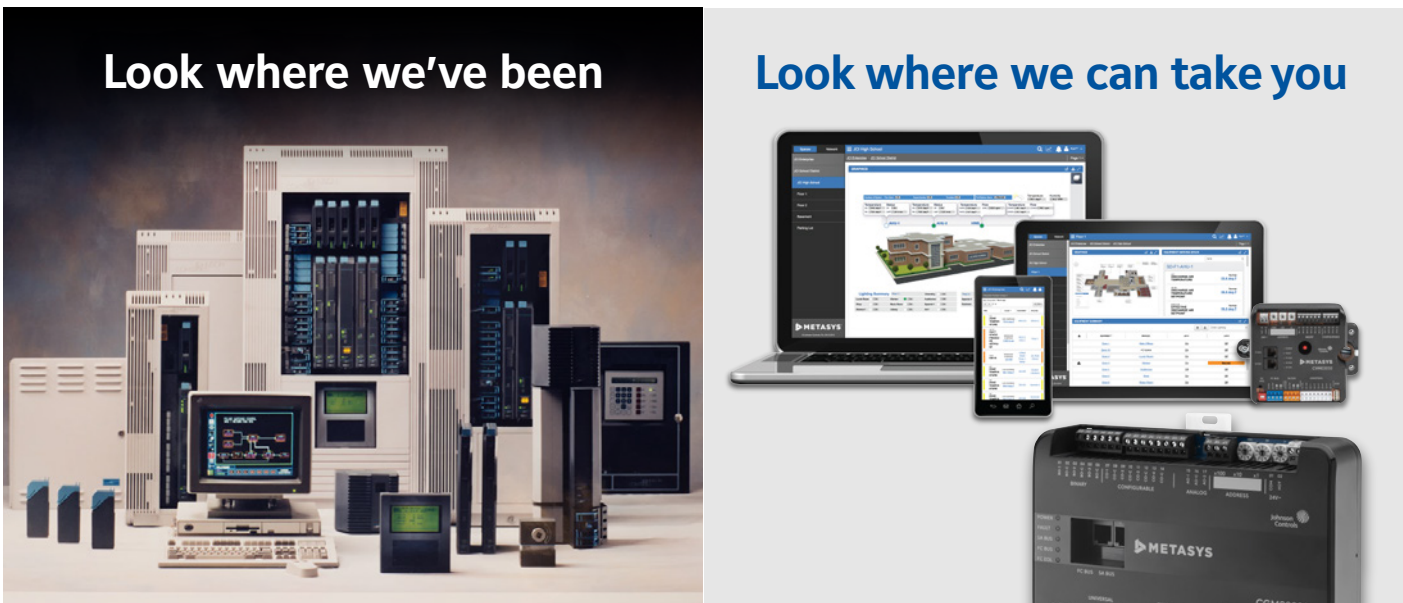

Imagine what you'd miss using a 30-year-old mobile phone. Now look at your BAS. Don't miss opportunities to help enhance security and productivity. See how to modernize with *Metasys*.

Take advantage of this exciting MUMS promotion now to enjoy the benefits of the new system upgrade and other bundled improvements.

There are a number of risks and drawbacks when you operate with obsolete software. Outdated software increases your vulnerability to threats and can have a significant impact on your productivity and efficiency.

Why should you update *Metasys*®?

⊗ No update

- 1. Increased risk of cyber attacks
- 2. Incompatibility with latest versions of Windows can lead to poor performance
- 3. Originally installed BMS controllers can become obsolete or operate incorrectly
- 4. Maximum productivity is cut and efficiency can be affected

✓ When you update

- 1. Your system will have the latest cybersecurity measures to meet the evolving threat landscape
- 2. A more intuitive user experience is provided
- 3. The latest technology will improve performance, reliability, and serviceability
- 4. You can accomplish tasks more quickly for boosted productivity

Metasys® User interface (MUI)

The Metasys® UI is designed for operators and facility managers who use computers, tablets, or smartphones to control and operate buildings.



Enhanced Security

- Encrypted communications
- Use of safety certificates
- User control
- Deactivate users who do not enter
- Complexity of passwords
- Cyberhealth panel
- Port 443 (encrypted)
- More control over who's entering your system

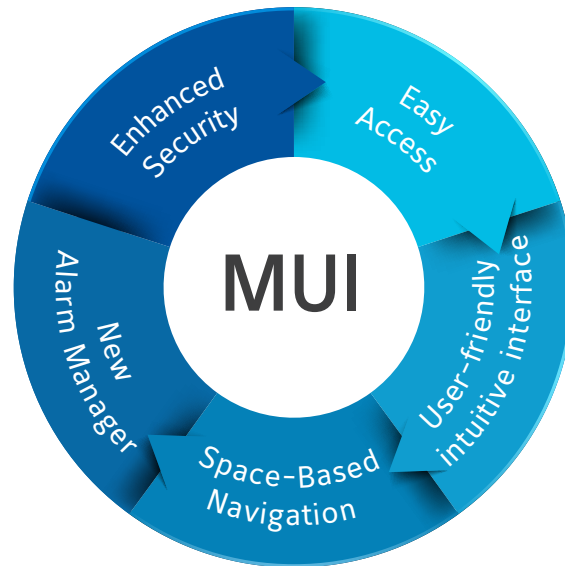

Easy Access

Supervisory/Overarching site control:

- Uses Open Communication protocols to integrate equipment controls from any OEM. This allows managers to visualize, manage and control all the mechanical and electrical equipment within the building
- Highly secured devices, with secure-boot and other built-in features
- Linux-based firmware that breaks dependencies on Windows software updates and support life cycles, avoiding costly updates over a short period of time



New Alarm Manager

Data Management Level

- Industry-leading HTML5 User Interface offers highly intuitive multi-device support that reduces time on task for operators
- Powerful yet simple User Management and Cybersecurity Dashboard allows facility managers to see user behaviors or devices that need updates
- Powerful alarm management



Space-Based Navigation

Easily view schedules by space or equipment to add multiple exceptions in a single operation.



User-Friendly Intuitive Interface

Field Control/Automation Level

- Bring the controls strategies to the very edge, guaranteeing that control strategies are dispersed and dedicated to the very equipment they control. This avoids single points of failure where one device runs control strategies for several pieces of equipment and causes them to stop operating when one fails.
- Highly reliable devices with longlasting operations on-site. The controllers are manufactured on a global platform serving critical customers and therefore follow the most stringent protocols of development and testing by Johnson Controls.
- Room Controls and Wall Interfaces also available to enable great user experiences to the tenants of the buildings.



Empowering new services enabled by technology and data

Tailored Service Solutions for HVAC

Adding digital capabilities to our service offerings

Johnson Controls never stands still. As a customer-centric business, we are always searching for new technologies, solutions and methods to deliver services to our partners. These are some of the new capabilities we have evolved into our digital portfolio.

Five key activities and new capabilities:

Activities	New capabilities
Inspection and diagnostics	Create early warnings to prevent significant equipment failures and reduce time to repair Technology: Advanced, automated and continuous fault detection diagnostics with analytical platform
Remote inspection	Reduce downtime and time to repair through early detection of potential product complications Technology: Connectivity for offsite customer product access to enable product inspection and provide insights on potential areas that need additional attention at the next onsite visit
Health reporting	Performance reviews to identify potential issues and provide proactive recommendations Technology: Remote product access for machine performance analysis
Multi-year investment plan	Better forecasting for long-term investment Technology: Examining the current status of products using advanced analytics to advise on repairs and preventive maintenance plans for improved forecasting of unexpected costs
Condition-based maintenance	Keep your products in the best condition, reduce unexpected downtime, and optimize investments Technology: State-of-the-art digital technologies to monitor and analyze your data for optimal operation

Peace of mind through connected observations

Our leading services portfolio combines innovative technology and the expertise of our people to enhance delivery. We utilize data-driven insights, AI and analytics capabilities to facilitate effective decision-making.



Contact your Johnson Controls representative to order the best service solution tailored to your needs.

Our Planned Service Agreement (PSA) philosophy

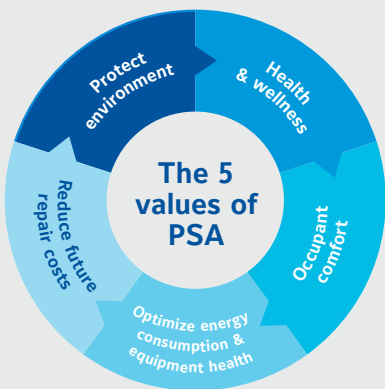

Five core values to guide your business

- Improve life safety for building occupants
- Ensure code compliance
- Optimize system readiness and uptime
- Reduce future repair costs
- Protect people, property and assets

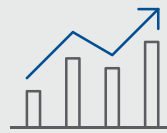

What goes up

- Working life of equipment
- Efficiency levels
- Occupant safety
- Peace of mind

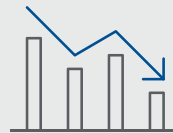

What goes down

- Operating costs
- Response time
- Unplanned downtime
- Total cost of ownership

Tailored Service Solutions powered by OpenBlue



Essential

All Essential maintenance for your product to keep it running and meet local regulations.



Enhanced

Adding continuous connectivity, enabling offsite observation and advisory services that deliver data-driven equipment health insights.



Expert

Improved equipment uptime supported by advanced Fault Detection and Diagnostics and remote specialist maintenance support by our domain experts.



Optimum

Proactive optimization of operating costs, equipment reliability and uptime through advanced predictive diagnostics. Expert maintenance support via machine learning and AI algorithms.

Lifecycle services

Helping your business and facilities run at peak performance over the complete lifecycle of your building

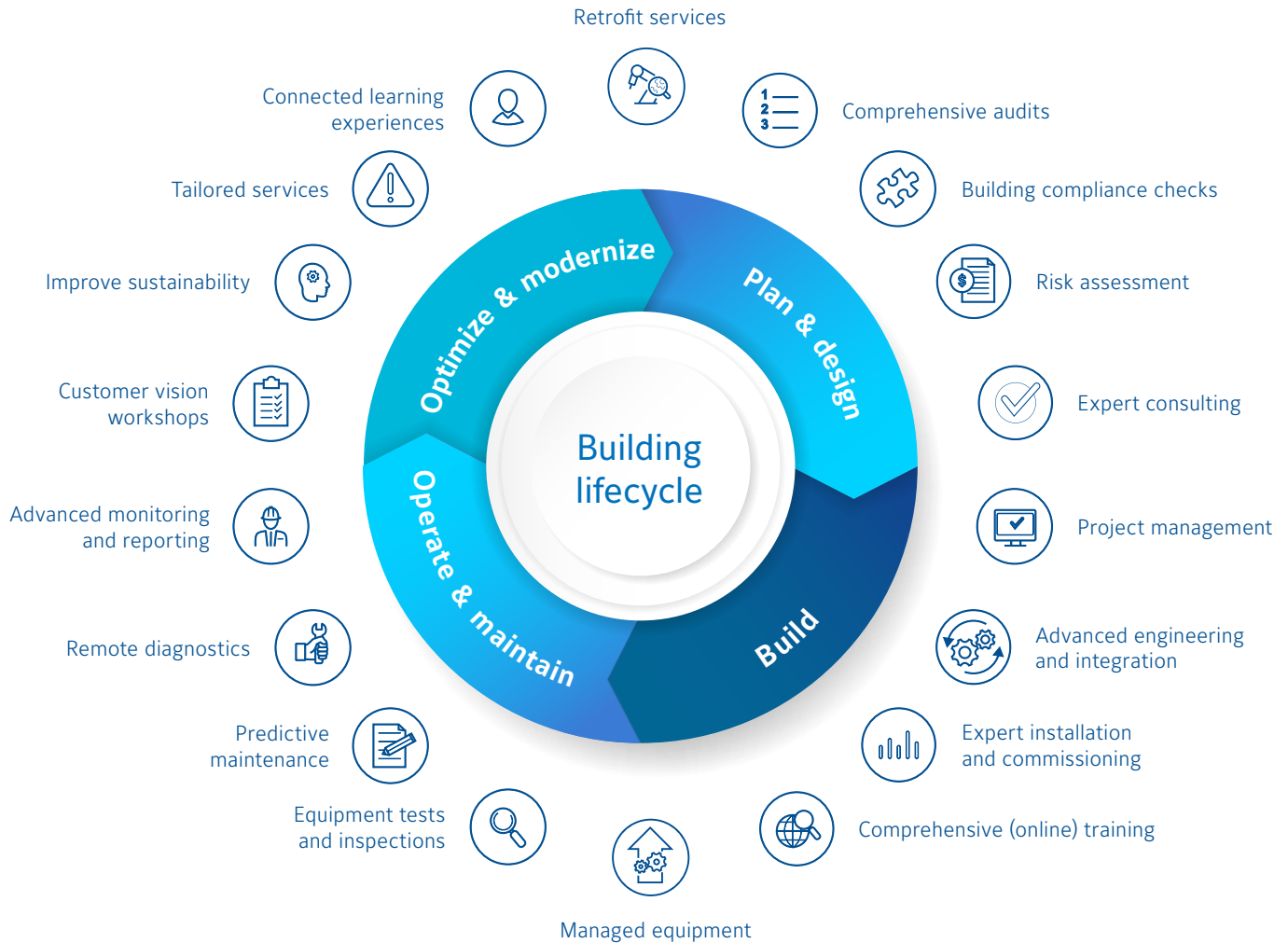

The Johnson Controls difference



Deep subject matter experts

Experienced service specialists at your fingertips. Providing best-in-class service is in our DNA.



OpenBlue technology

OpenBlue AI technology empowers you to manage your operations more systematically for greater visibility, enhanced performance, proactive planning, and overall building optimization.



Tailored and flexible offerings

We offer scalable service options across a comprehensive range of HVAC, fire protection, and security services, delivering the services you want, the way you want them.

Solution Navigator

We are with you all the way.

After interviewing more than 100 customers to gather a deep insight into their needs, we understood how vital it was to transform our web portal, Virtual Branch, into a digital customer-enablement platform in motion.

This led to us launching Solution Navigator, the comprehensive digital platform by Johnson Controls you need to easily navigate the product lifecycle in HVAC, Industrial Refrigeration, Building Automation Systems & Controls, Fire and Security. This powerful customer portal improves channel partner productivity, provides value-added services and enhances communications to strengthen our customers' footholds and development in the marketplace.

Through this portal, customers can accomplish fundamental tasks, such as ordering products, managing warranties and getting installation guidance, while enjoying a consistent, outstanding experience.

Call your Sales Representative and request access now.

<https://www.solutionnavigator.com/>

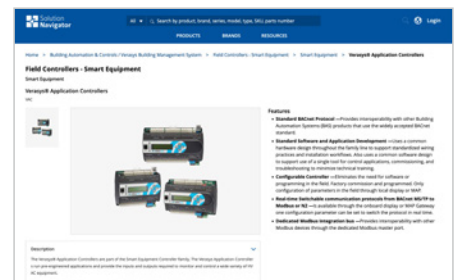
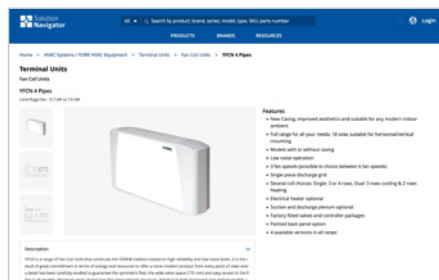
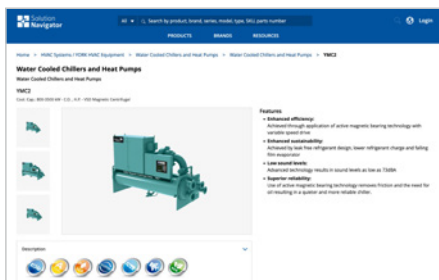
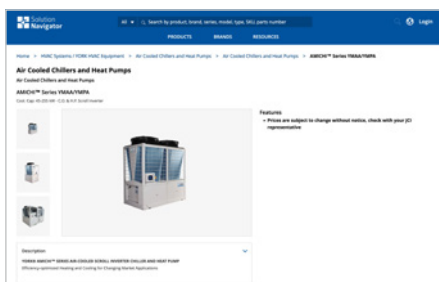
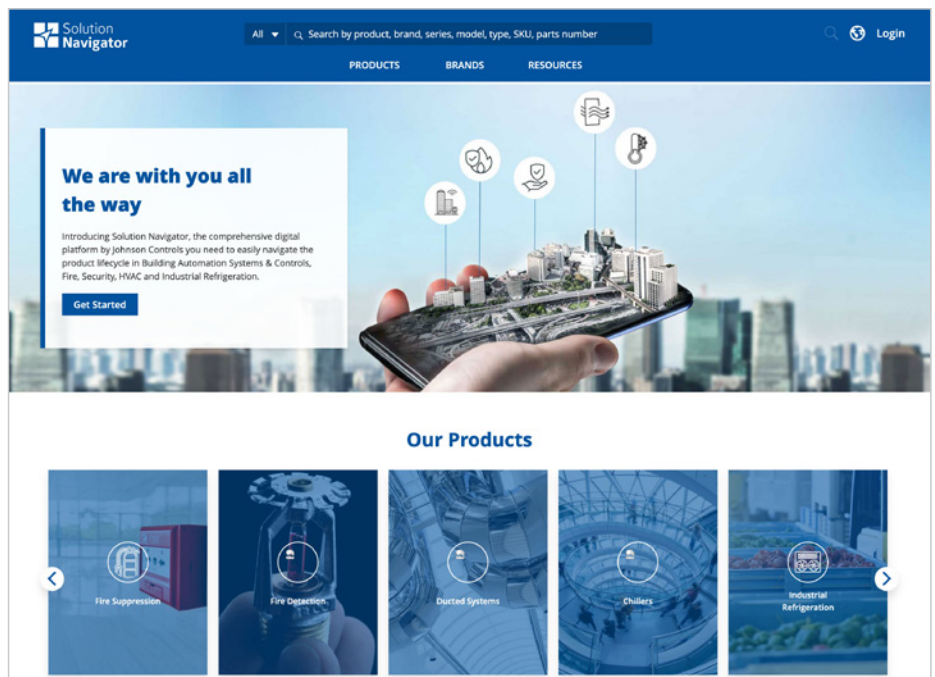

Fast-forward to today and we are delighted to share with you the evolution of this self-serve solution. Tuning in, once again, to customer feedback, we've gone further - much further.





About Johnson Controls

At Johnson Controls, we transform the environments where people live, work, learn and play. From optimizing building performance to improving safety and enhancing comfort, we drive the outcomes that matter most. We deliver our promise in industries such as healthcare, education, data centers and manufacturing.

With a global team of 100,000 experts in more than 150 countries and over 130 years of innovation, we are the power behind our customers' mission. Our leading portfolio of building technology and solutions includes some of the most trusted names in the industry, such as Tyco®, YORK®, Metasys®, Sabroe®, Frick®, ZETTLER® and Sensormatic®.

For additional information, please visit www.johnsoncontrols.com or follow us [@johnsoncontrols](https://twitter.com/johnsoncontrols) on Twitter.