

YORK Fan Coil units

Driven by innovative trends and modern technology, the YORK Fan Coil Units have been designed around a platform of models, versions and accessories, which have been independently tested and certified by Eurovent. The YORK Fan Coil range meets today's demanding requirements of performance, size, acoustics, low energy, ease of installation and maintenance.



An extensive offering

- One of the **most versatile** ranges of fan coils on the market today. Wall and ceiling mounted units, exposed or concealed with centrifugal fan, are included, and with cooling capacities ranging from 0.6 kW to 9.7 kW.
- Dramatic **electrical consumption reduction** of up to 40% comparative to previous models. This is achieved thanks to the supply of all YORK Fan Coil Units equipped with centrifugal fans and electric motors, and with 6 speed motors as standard to offer greater flexibility in the selection of products.
- Energy saving brushless motor** technology option available. Its combination with a dedicated frequency inverter and unit controller to regulate the fan speed enables higher efficiencies, even at low rotational speeds, lower unit noise, constant speed characteristics and an increase in motor lifetime expectancy. In comparison to the traditional units equipped with asynchronous three-speed-motors, units with brushless motors can obtain a considerable energy saving, by reducing the power consumption by up to 70%.
- A full range of **factory fitted Johnson Controls valve and pre-configured control options** is offered. This in addition to a patented 'wireless' control option - offering greater flexibility in the installation of units, with the highest precision in monitoring and maintaining the desired comfort conditions.
- Many of our ranges are available configured for use with 60Hz voltage, and specially designed cooling coils for **District Cooling applications**.
- High pressure 'Blower' units** are also available. They can offer up to 29.4 kW of cooling at External Static Pressures of up to 250Pa, and are complemented with a full range of options and accessories covering items such as electrical heating battery, air inlet/outlet diffusers and condensate pumps.



Iconography



Infrared or
Wired control



Wired
control



Dry mode



Timer



Auto
Restart



Sleep
mode



Auto
Sweep



Ducted
Installation



4 Way
Air Flow



Air Filter

YFCN Fan Coil Unit with centrifugal fan

2 & 4 pipe system

A complete range from 0.7 kW to 7.4 kW



YFCN is a range of Fan Coil Units that continues the YORK tradition based on high reliability and low noise levels. It is the result of great commitment in terms of energy and resources to offer a more modern product from every angle, while still delivering the convenience of easy access to the filters in all models.

Moreover each version has the same internal structure, identical in both horizontal and vertical models, in order to standardise production and guarantee a greater flexibility in distribution and installation.



Selection software

Wired controls



T9000 Series

• **Red Dot Product Design Award Winner 2020**

- Touch Screen Display
- 2 or 4 pipes FCU
- 3-speed motors or ECM motors
- 2-wiring/3-wiring on/off valves or proportional valves
- Relay designed for 100,000 switching cycles
- Modbus or BACnet protocols



T7600 Series

- LCD Screen Display
- 2 or 4 pipes FCU
- On/off or proportional
- 3-speed motors or ECM motors
- Modbus RTU



Infrared control



TUC03+ Terminal unit controller

BacNET and N2 Metasys network compatible



Features

- New casing, improved aesthetics, suitable for any modern indoor ambient
- Full range for all needs: 9 sizes suitable for horizontal or vertical mounting with or without casing
- Low noise operation
- 3 fan speeds (possible choice between 6 fan speeds)
- Single piece discharge grid
- Several coil choices.
 - Single: 3 or 4 rows; Dual: 3 rows cooling and 2 rows heating
- Electrical heater optional
- Suction and discharge plenum optional
- Factory fitted valve (on/off or modulating) and controller packages
- Painted back panel option
- 4 available versions in all range:
 - VC = Vertical Discharge with Casing
 - VCB = Vertical Discharge with Casing (floor installation)
 - HC = Horizontal Discharge with Casing
 - CD = Concealed unit without Casing
- EUROVENT Certified

YFCN Fan Coil Unit with centrifugal fan

0.7 kW to 7.4 kW

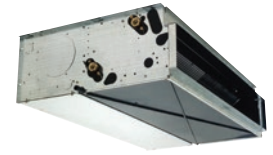

Technical features

YFCN model (2 pipes)		140	240	340	440	540	640	740	840	940	
Total cooling capacity [kW]	(1)	max	1.20	1.78	2.53	3.08	4.03	4.71	5.48	6.34	7.42
		med	1.00	1.41	1.87	2.25	3.21	3.81	4.56	5.63	6.41
		min	0.65	1.00	1.63	1.81	2.17	2.79	3.51	3.97	4.79
Sensible cooling capacity [kW]	(1)	max	0.94	1.35	1.86	2.30	3.01	3.52	4.13	4.93	5.87
		med	0.77	1.05	1.36	1.65	2.36	2.81	3.39	4.33	4.98
		min	0.49	0.73	1.18	1.32	1.58	2.03	2.57	2.98	3.63
Pressure drop in cooling [kPa]	(1)	max	5.6	13.9	11.5	15.5	31.3	36.2	27.7	32.2	23.2
		med	4	9.1	6.7	9	20.8	24.8	20	26.0	17.8
		min	1.9	4.9	5.3	6.1	10.4	14.4	12.5	14.0	10.6
Heating capacity [kW]	(2)	max	1.31	1.83	2.59	3.14	4.01	4.92	5.59	7.20	8.52
		med	1.07	1.43	1.87	2.27	3.16	3.90	4.62	6.27	7.18
		min	0.69	0.99	1.62	1.80	2.10	2.82	3.49	4.26	5.23
Pressure drop in heating [kPa]	(2)	max	5.3	11.8	9.8	12.8	25.2	31.8	23.2	31.7	23.7
		med	3.7	7.6	5.4	7.2	16.6	21.1	16.6	24.9	17.6
		min	1.7	4.0	4.2	5.0	8.1	11.9	10.1	12.8	10.0
Air flow [m³/h]		max	220	295	385	485	650	760	925	1 200	1 500
		med	175	220	270	335	495	590	735	1 020	1 210
		min	105	145	235	265	315	415	535	655	830
Fan [W]		max	33	32	41	44	46	78	103	130	176
		med	25	22	25	28	39	55	79	105	134
		min	16	14	20	21	22	37	54	62	92
Sound power level [dB(A)]		max	45	47	49	47	48	52	56	60	64
		med	39	40	40	39	41	46	51	56	58
		min	32	30	36	33	31	37	42	45	50
Sound pressure level [dB(A)]	(4)	max	36	38	40	38	39	43	47	51	55
		med	30	31	31	30	32	37	42	47	49
		min	23	21	27	24	22	28	33	36	41
Power supply [V-ph-Hz]		230 / 1 / 50 + E									
Dimensions *	Height	mm	530	530	530	530	530	530	530	530	530
	Width	mm	670	770	985	985	1 200	1 200	1 415	1 415	1 415
	Depth	mm	225	225	225	225	225	225	225	255	255

YFCN model (4 pipes)		140+1	240+1	340+1	440+1	540+1	640+1	740+1	840+1	940+1	
Total cooling capacity [kW]	(1)	max	1.20	1.78	2.53	3.08	4.03	4.71	5.48	6.34	7.42
		med	1.00	1.41	1.87	2.25	3.21	3.81	4.56	5.63	6.41
		min	0.65	1.00	1.63	1.81	2.17	2.79	3.51	3.97	4.79
Sensible cooling capacity [kW]	(1)	max	0.94	1.35	1.86	2.30	3.01	3.52	4.13	4.93	5.87
		med	0.77	1.05	1.36	1.65	2.36	2.81	3.39	4.33	4.98
		min	0.49	0.73	1.18	1.32	1.58	2.03	2.57	2.98	3.63
Pressure drop in cooling [kPa]	(1)	max	5.6	13.9	11.5	15.5	31.3	36.2	27.7	32.2	23.2
		med	4	9.1	6.7	9	20.8	24.8	20	26.0	17.8
		min	1.9	4.9	5.3	6.1	10.4	14.4	12.5	14.0	10.6
Heating capacity [kW]	(3)	max	0.91	1.33	1.99	2.33	3.00	3.33	4.20	4.75	5.46
		med	0.77	1.09	1.56	1.81	2.50	2.79	3.59	4.26	4.79
		min	0.55	0.83	1.40	1.52	1.84	2.19	2.89	3.16	3.71
Pressure drop in heating [kPa]	(3)	max	1.3	3.1	7.8	10.3	2.6	3.8	6.7	8.3	10.7
		med	1.0	2.2	5.1	6.6	2.3	2.8	5.1	6.9	8.5
		min	0.5	1.3	4.2	4.9	1.3	1.8	3.5	4.1	5.4
Air flow [m³/h]		max	330	515	505	735	720	890	875	1 395	1 365
		med	220	350	340	495	475	610	585	945	910
		min	120	210	200	305	290	400	380	605	575

(1) Room temperature 27°C d.b., 19°C w.b. - Water temperature 7/12 °C.

(2) Room temperature 20°C - Water temperature 45/40 °C. (3) Room temperature 20°C - Water temperature 65/55 °C.

(4) The sound pressure levels are 9 dB(A) lower than the sound power levels and apply to the reverberant field of a 100 m³ room and a reverberation time of 0.5 sec.

* Dimensions refer to the units with casing.

Data shown is for 4 row cooling version.

For performance of 3 row cooling version please contact your local Johnson Controls sales office.



Manufacturer reserves the rights to change specifications without prior notice.

ECM Technology



Running costs. Energy consumption. Life cycle.

These are 3 issues that are becoming more and more important in the choice of Fan Coil Units. With these criteria in mind, Johnson Controls offers the ECM range of FCU.

ECM technology comprises a **brushless motor** combined to a **dedicated electronic device** (inverter). In comparison to conventional units equipped with asynchronous three-speed motors, the fancoil and cassette units with brushless motors can obtain a considerable energy saving, by **reducing power consumption up to 70%**.

Air flow rate can be varied in continuous by means of a 0-10V signal generated both by our controls or by independent controls systems. The continuous air flow control improves the **acoustic comfort** and allows a more punctual reply to the variation of the thermal loads, enhancing the **stability of ambient temperature**.

Technology

ECM technology consists of a brushless motor combined with an inverter managed by specific regulators. The controller uses a 0-10 VDC modulating signal to regulate the fan speed.

The brushless electric motor is composed of a rotor having permanent magnets, whose magnetic fields interact with the ones produced by the stator winding. The **transfer of current is no longer by mechanical commutator** (sliding contacts) **but by an electronic commutation system**: one electronic controller (inverter) powers the motor's stator and generates rotating magnetic fields, that in turn determine the rotor's speed.

Brushless motor develop much less heat than the traditional brushed motors and they have much lower mechanical resistance than the standard asynchronous maintenance. The absence of brushes eliminates also the main source of electromagnetic noise.

Power consumption: YFCN versus YFCN-ECM (W/kW)

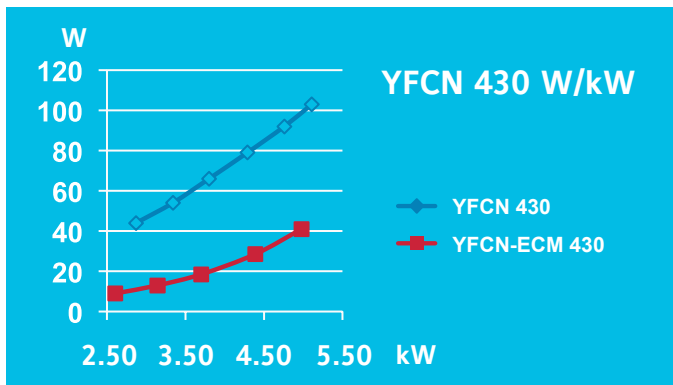

Features

- Brushless motor with inverter.
- 0-10VDC control signal.
- Low mechanical resistance and heat gain
- Continuous regulation of the fan speed.
- Specifically designed electronic and digital regulators, also for BMS systems.
- Possibility to manually set the desired three fan speeds (MIN/MED/MAX).

Advantages (compared to traditional brushed motors)

- Energy saving: electrical absorption reduced up to 70%.
- Higher efficiency: possibility to adapt the air volume and the capacities accordingly to the actual room loads.
- Higher comfort: reduced variation of the temperature and relative humidity in the room.
- Extremely quiet operation.
- Reduced wear and higher reliability.
- Longer life expectancy of the motor.

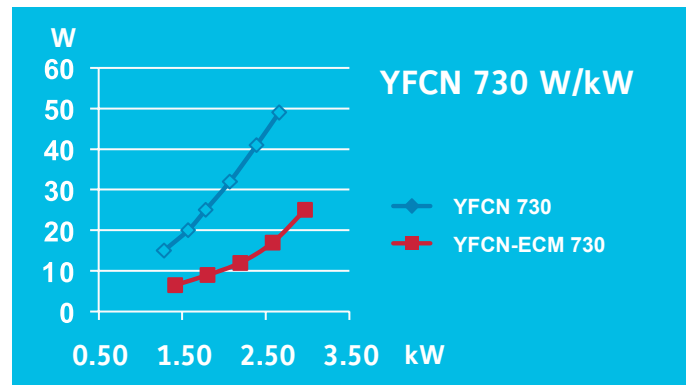

YFCN-ECM Inverter Fan Coil Unit with centrifugal fan

0.7 kW to 7.1 kW



Technical features

YFCN-ECM model (2 pipes)			230	240	430	440	630	640	730	740	930	940
Total cooling capacity [kW]	(1)	max 10v	1.59	1.86	2.95	3.17	3.96	4.51	4.94	5.30	6.26	7.04
		med 5v	1.18	1.32	2.18	2.27	2.93	3.19	3.68	3.82	4.82	5.21
		min 1v	0.73	0.77	1.41	1.43	1.96	2.05	2.60	2.61	3.45	3.59
Sensible cooling capacity [kW]	(1)	max	1.28	1.42	2.26	2.39	3.08	3.38	3.80	3.99	5.10	5.53
		med	0.92	0.98	1.64	1.67	2.22	2.34	2.77	2.82	3.79	3.99
		min	0.55	0.56	1.03	1.03	1.46	1.48	1.92	1.90	2.63	2.69
Pressure drop in cooling [kPa]	(1)	max	8.6	14.8	28.9	16.1	19	33	32.6	25.6	25.9	20.8
		med	5.1	8	17	8.9	11.1	17.8	19.4	14.3	16.1	12.1
		min	2.2	3.2	7.9	4	5.5	8.2	10.5	7.3	8.9	6.3
Heating capacity [kW]	(2)	max	1.80	1.98	3.14	3.32	4.14	4.68	5.08	5.43	7.38	7.93
		med	1.29	1.37	2.26	2.30	3.00	3.23	3.72	3.84	5.41	5.63
		min	0.77	0.78	1.42	1.42	1.96	2.02	2.56	2.57	3.74	3.76
Pressure drop in heating [kPa]	(2)	max	7.0	13.6	26.7	13.7	17.0	29.1	28.3	22.0	24.2	20.9
		med	3.9	7.1	14.9	7.3	9.6	15.1	16.4	12.0	14.0	11.4
		min	1.6	2.6	6.6	3.1	4.5	6.6	8.5	5.9	7.3	5.6
Air flow [m³/h]		max	330	325	515	505	735	720	890	875	1 395	1 365
		med	220	210	350	340	495	475	610	585	945	910
		min	120	115	210	200	305	290	400	380	605	575
Fan [W]		max	21	21	25	25	32	32	41	41	99	99
		med	11	11	12	12	15	15	19	19	41	41
		min	7	7	6	6	7	7	9	9	16	16
Sound power level [dB(A)]		max	51	51	51	51	54	54	57	57	64	64
		med	41	41	42	42	44	44	48	48	55	55
		min	30	30	30	32	33	33	37	37	44	44
Sound pressure level [dB(A)]	(4)	max	42	42	42	42	45	45	48	48	55	55
		med	32	32	33	33	35	35	39	39	46	46
		min	21	21	21	23	24	24	28	28	35	35
Power supply [V-ph-Hz]			230 / 1 / 50 + E									
Dimensions *	Height	mm	530	530	530	530	530	530	530	530	530	530
	Width	mm	770	770	985	985	1 200	1 200	1 415	1 415	1 415	1 415
	Depth	mm	225	225	225	225	225	225	225	225	255	255

YFCN-ECM model (4 pipes)			230+1	240+1	430+1	440+1	630+1	640+1	730+1	740+1	930+1	940+1
Total cooling capacity [kW]	(1)	max 10v	1.59	1.86	2.95	3.17	3.96	4.51	4.94	5.30	6.26	7.04
		med 5v	1.18	1.32	2.18	2.27	2.93	3.19	3.68	3.82	4.82	5.21
		min 1v	0.73	0.77	1.41	1.43	1.96	2.05	2.60	2.61	3.45	3.59
Sensible cooling capacity [kW]	(1)	max	1.28	1.42	2.26	2.39	2.88	3.38	3.80	3.99	5.10	5.53
		med	0.92	0.98	1.64	1.67	2.08	2.34	2.77	2.82	3.79	3.99
		min	0.55	0.56	1.03	1.03	1.37	1.48	1.92	1.90	2.63	2.69
Pressure drop in cooling [kPa]	(1)	max	9.40	14.8	28.10	16.1	23.30	33	31.80	25.6	25.90	20.8
		med	5.40	8.0	16.00	8.9	13.20	17.8	18.40	14.3	16.10	12.1
		min	2.30	3.2	7.30	4.0	6.40	8.2	9.70	7.3	8.90	6.3
Heating capacity [kW]	(3)	max	1.43	1.43	2.41	2.41	3.22	3.22	4.06	4.06	5.24	5.24
		med	1.08	1.08	1.85	1.85	2.45	2.45	3.13	3.13	4.05	4.05
		min	0.71	0.71	1.29	1.29	1.76	1.76	2.33	2.33	2.99	2.99
Pressure drop in heating [kPa]	(3)	max	3.5	3.5	11.0	3.5	3.6	3.6	6.3	6.3	9.9	9.9
		med	2.1	2.1	6.9	2.1	2.2	2.2	4.0	4.0	6.3	6.3
		min	1.0	1.0	3.6	1.0	1.2	1.2	2.4	2.4	3.7	3.7
Air flow [m³/h]		max	330	325	515	505	735	720	890	875	1 395	1 365
		med	220	210	350	340	495	475	610	585	945	910
		min	120	115	210	200	305	290	400	380	605	575

(1) Room temperature 27°C d.b., 19°C w.b. - Water temperature 7/12 °C

(2) Room temperature 20°C - Water temperature 45/40 °C

(3) Room temperature 20°C - Water temperature: 65/55°C

(4) The sound pressure levels are 9 dB(A) lower than the sound power levels and apply to the reverberant field of a 100 m³ room and a reverberation time of 0.5 sec.

* Dimensions refer to the units with casing



Manufacturer reserves the rights to change specifications without prior notice.

Options/Accessories

Compatibility table / Codes

Model	YFCN AC motor control devices		
	VC/VCB model Vertical with casing	HC model Horizontal with casing	CD model Without casing
Controls for style VC (supplied with separate packaging)			
Three speed control MV-3V (1)	9060130	-	-
Three speed control + electronic thermostat and S/W switch TMV-S (2)	9060140	-	-
Three speed control + electronic thermostat and centralized S/W - TMV-C (2)	9060133	-	-
Automatic speed control with electronic thermostat and S/W switch TMV-AUT (2)	9066319	-	-
Controls for style HC/CD (supplied with separate packaging)			
Remote three speed control WM-3V (1) (4)	-	9066642	9066642
Remote three speed control + electronic thermostat JWC-T and manual S/W switch (2)	-	9066630K	9066630K
Remote three speed control + electronic thermostat and centralized/manual S/W switch JWC-TQR (2) (3)	-	9066631K	9066631K
Automatic speed control with electronic thermostat and S/W switch - JWC-AU (to be used with UPM-AU and UP-AU only) (2) (3)	-	9066632K	9066632K
Automatic remote control with electronic thermostat, S/W switch and liquid crystall display T-MB (to be used with UPM-AU and UP-AU) (2) (3)	-	9066331E	9066331E
Automatic speed control with electronic thermostat to be mounted in the light wall box WM-503-AC-EC (to be used with UP-503-AC-EC only)	-	9066686E	9066686E
Electromechanical thermostat T2T (4) (5)	-	9060174	9060174
Power unit UPM-AU for JWC-AU and T-MB remote controls, fitted on the unit	9066641	9066641	9066641
Power unit UP-AU for JWC-AU and T-MB remote controls, not fitted on the unit	9066640	9066640	9066640
Power unit UP-503-AC-EC for WM-503-AC-EC remote control only, not fitted on the unit	9066687	9066687	9066687
Controls accessories for all versions (supplied with separate packaging)			
Low temperature cut-out for controls TME	3021091	3021091	3021091
Low temperature cut-out for controls TMV-S, WM-3V and JWC-T	9053048	9053048	9053048
Low temperature cut-out for controls TMV-AUT, TMV-AUT-E, JWC-TQR, WM-503-AC-EC and UP-AU power unit	3021090	3021090	9053049
T2 sensor to be used as Change-over for controls TMV-AUT, TMV-AUT-E and UP-AU power unit	9025310	9025310	9025310
Change-over 15-25 for control TMV-C and JWC-TQR	9053049	9053049	9053049
Receiving speed selector for centralized control (slave) SEL-V (for VC/VCB units)	9060136	-	-
Receiving speed selector for centralized control (slave) SEL-CR (for HC/CD units)	9066311	9066311	9066311
Terminal board adaptor kit KIT	9060103	-	-
Controls for style VC + additional electric resistance (supplied with separate packaging)			
Three speed control with electronic thermostat and S/W switch TMV-R-IAQ	9063006	-	-
Automatic speed control with electronic thermostat and S/W switch TMV-AUT-E (2) (3)	9066643	-	-
Controls for style HC/CD + additional electric resistance (supplied with separate packaging)			
Remote three speed control + electronic thermostat and centralized/manual S/W switch JWC-TQR (2) (3)	-	9066631K	9066631K
Automatic speed control with electronic thermostat and centralized S/W - JWC-AU (for UP-AU) (2) (3)	-	9066632K	9066632K
Automatic remote control with electronic thermostat, S/W switch and liquid crystall display T-MB (for UP-AU) (2) (3)	-	9066331E	9066331E

WARNING

(1) Not to be used with valves. (2) Can be used with valves and/or low temperature cut-out. (3) Can be used with Change Over.
 (4) Not suitable with -E electric heater. (5) To be used with valve and not to be used with low temperature cut-out.

Options/Accessories

Compatibility table / Codes

Model	YFCN AC motor control devices
Versions	ALL VERSIONS: VC/VCB - Vertical w. casing + HC - Horizontal with casing + CD without casing ALL VERSIONS: VC/VCB + HC + CD with electric heater
Controls and accessories for all versions	
Mounted power unit MB-M	9066332
Not mounted power unit MB-S	9066333
Wall control T-MB	9066331E
IR remote control and mounted IR receiver RM-RT03	9066336
IR remote control and not mounted IR receiver RS-RT03	9066337
IR remote control RT03	3021203
Mounted IR receiver RM	9066339
Not mounted IR receiver RS	9066338
Multifunction wall control up to 60 units PSM-DI	3021293
T2 sensor (to be used as Change-over or minimum temp. Sensor)	9025310
Management system for a network of fan coils with MB electronic board	
Hardware/software supervisory system (to be used with MB board only) NET	9079118
Router-S for NET (default) or for BMS systems not provided by YORK	3021290
Relay output board SIOS	3021292

With T-MB wall control

One control for each unit
(Maximum length of the connection cable = 20 m)



One control for more units in master/slave configuration (20 units max.)
(Maximum total length of the connection cable = 800 m)

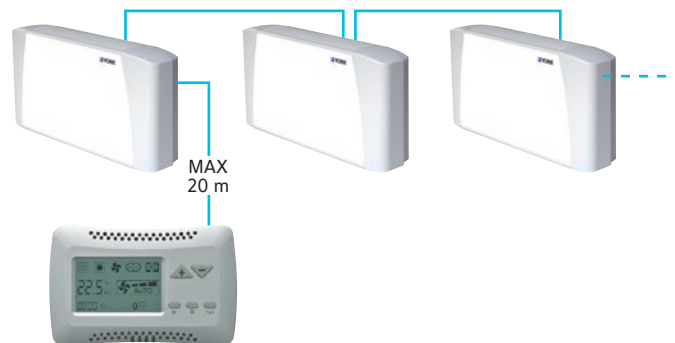

With RT03 Infra-red remote control

One control for each unit



One control for more units in master/slave configuration (20 units max.)
(Maximum total length of the connection cable = 800 m)



Options/Accessories

Compatibility table / Codes

Model	YFCN ECM motor control devices		
Versions	VC/VCB model Vertical with casing	HC model Horizontal with casing	CD model Without casing
Controls accessories for all versions (supplied with separate packaging)			
Low temperature cut out NTC for control TMV-T-ECM, WM-S-ECM and UP-AU power unit		3021090	
T2 sensor to be used as Change-over for UP-AU power unit		9025310	
Change over CH 15-25 for control TMV-T-ECM		9053049	
Controls for style VC (supplied with separate packaging)			
Continuous fan speed control with electronic thermostat and S/W switch TMV-T-ECM (for standalone units - not for MB)	9060141	-	-
Controls for style HC/CD (supplied with separate packaging)			
JWC-AU Automatic speed control with electronic thermostat and centralized S/W switch (not for MB) (1) (2)	-	9066632K	9066632K
T-MB Automatic remote control with electronic thermostat, S/W switch and liquid crystall display (1) (2)	-	9066331E	9066331E
WM-S-ECM Continuous fan speed control with S/W switch and liquid crystall display (for standalone units - not for MB)	-	9066644	9066644
UPM-AU power unit for JWC-AU and T-MB remote controls, fitted on the unit (not MODBUS)	9066641	9066641	9066641
UP-AU power unit for JWC-AU and T-MB remote controls, not fitted on the unit (not MODBUS)	9066640	9066640	9066640
Accessories of controls for VC, HC-VCB and CD models (supplied with separate packaging)			
MB-ECM-M mounted power unit for ECM fan coil	9066334	9066334	9066334
MB-ECM-S not mounted power unit for ECM fan coil	9066335	9066335	9066335
Wall control T-MB	9066331E	9066331E	9066331E
IR remote control and mounted IR receiver RM-RT03	9066336	9066336	9066336
IR remote control and not mounted IR receiver RS-RT03	9066337	9066337	9066337
IR remote control RT03	3021203	3021203	3021203
Mounted IR receiver RM	9066339	9066339	9066339
Not mounted IR receiver RS	9066338	9066338	9066338
Multifunction wall control up to 60 units PSM-DI	3021293	3021293	3021293
T2 sensor (to be used as Change-over or minimum temperature Sensor)	9025310	9025310	9025310
Management system for a network of fan coils with MB electronic board			
Hardware / software supervisory system Net	9079118	9079118	9079118
Router-S for NET (default) or for BMS systems not provided by YORK	3021290	3021290	3021290
Relay output board SIOS	3021292	3021292	3021292

(1) Can be used with valves and/or low temperature cut-out. (2) Can be used with Change Over.

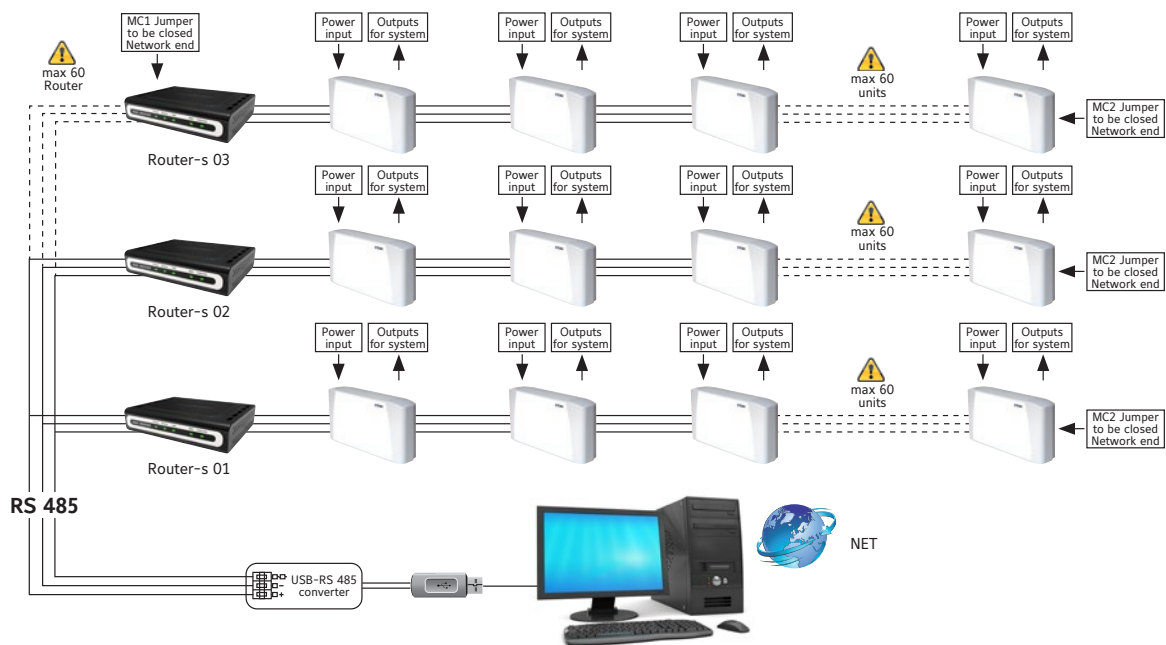

Options/Accessories

Compatibility table / Codes

Model	YFCN General accessories								
	130/140	230/240	330/340	430/440	530/540	630/640	730/740	830/840	930/940
Valves all versions									
3 way double valve kit for 4 tube installation and single coil + kit fitted on the unit					9066572W				
3 way double valve kit for 4 tube installation and single coil + kit not fitted on the unit					9066562W				
Kit 3 way valve mounted			9066561			9060471			
Kit 3 way valve additional battery mounted					9060472				
Kit 3 way valve not mounted			9066560			9060474			
Kit 3 way valve additional battery not mounted					9060475				
Kit 2 way valve primary and/or additional battery mounted (*)			9060476			9060476 (*)			
Kit 2 way valve primary battery mounted			-			9060477			
Kit 2 way valve primary and/or additional battery not mounted (*)			9060478			9060478 (*)			
Kit 2 way valve primary battery not mounted			-			9060479			
Valves CD versions only									
Simplified 3-way valve kit for CD version fitted			9066571			9060484			
Simplified 3-way valve kit for CD version not fitted			9066570			9060481			
Simplified 3-way valve kit for CD version fitted - additional battery					9060483				
Simplified 3-way valve kit for CD version not fitted - additional battery					9060480				
Electric heater VC/VCB/CH version									
El. resistance and relays fitted on the unit (700 W) VC/HC	9066491E		-						
El. resistance and relays fitted on the unit (400 W) VC/HC	-	9066472E		-					
El. resistance and relays fitted on the unit (600 W) VC/HC	-	9066482E		9066473E		-			
El. resistance and relays fitted on the unit (750 W) VC/HC			-		9066475E		-		
El. resistance and relays fitted on the unit (900 W) VC/HC	-		9066483E			-			
El. resistance and relays fitted on the unit (1000 W) VC/HC	-	9066492E		-			9066477E		
El. resistance and relays fitted on the unit (1250 W) VC/HC			-		9066485E		-		
El. resistance and relays fitted on the unit (1500 W) VC/HC	-		9066493E			-		9066487E	
El. resistance and relays fitted on the unit (2000 W) VC/HC			-			9066495E		-	
El. resistance and relays fitted on the unit (2500 W) VC/HC			-			9066497E			
Electric heater CD version									
El. resistance and relays fitted on the unit (700 W) CD	9066611		-						
El. resistance and relays fitted on the unit (400 W) CD	-	9066592		-					
El. resistance and relays fitted on the unit (600 W) CD	-	9066602		9066593		-			
El. resistance and relays fitted on the unit (750 W) CD			-		9066595		-		
El. resistance and relays fitted on the unit (900 W) CD	-		9066603			-			
El. resistance and relays fitted on the unit (1000 W) CD	-	9066612		-			9066597		
El. resistance and relays fitted on the unit (1250 W) CD			-		9066605		-		
El. resistance and relays fitted on the unit (1500 W) CD	-		9066613			-		9066607	
El. resistance and relays fitted on the unit (2000 W) CD			-		9066615		-		
El. resistance and relays fitted on the unit (2500 W) CD			-			9066617			

(*) For additional battery sizes 6 to 9.

Options/Accessories

Compatibility table / Codes

Model	YFCN General accessories								
	130/140	230/240	330/340	430/440	530/540	630/640	730/740	830/840	930/940
Accessories for all versions									
Pair feet	9060150						9060151		
Vertical auxiliary condensate tray	6060400								
Horizontal auxiliary condensate tray for HC (left connections)	6060402								
Horizontal auxiliary condensate tray for HC (right connections)	6060403								
Horizontal auxiliary condensate tray for CD	6066039								
Condensate pump for VC - VCB - CD fitted on the unit auxiliary condensate collection tray included (vertical installation)	9066297								
Condensate pump for VC - VCB - CD not fitted on the unit auxiliary condensate collection tray included (vertical installation)	9066296								
Condensate pump for CD fitted on the unit auxiliary condensate collection tray to be ordered separately (horizontal installation)	9066298								
Condensate pump for CD not fitted on the unit auxiliary condensate collection tray included (horizontal installation)	9066180								
Condensate drain pipe	6060420								
Damper for CD model	9066531	9066532	9066533	9066535	9066537	9066538			
Damper for VC model	9076331	9076332	9076333	9076335	9076337	9076338			
Kit breeze	-	9076452	9076453	9076455	-				
Recessed box for kit breeze	-	9076462	9076463	9076465	-				
Rear closing panel VC	9062005	9060180	9060181	9060182	9060183				
Rear closing panel HC	9060187	9060190	9060191	9060192	9060193	9060194			
Frontal air intake CD mounted	9066501	9066502	9066503	9066505	9066507	9066508			
Intake grid for VC with feet	9066541	9066542	9066543	9066545	9066547				
Accessories only for concealed version CD									
Outlet flange 90° FM90	9066381	9066382	9066383	9066385	9066387	9066388			
Inlet flange 90° FR90	9066441	9060710	9060711	9060712	9060713	9060714			
Straight inlet flange FRD	9066451	9060720	9060721	9060722	9060723	9060724			
Straight outlet flange FMD	9066371	9066372	9066373	9066375	9066377	9066378			
Outlet spigot diffuser PMC	9066361	9066362	9066363	9066365	9066367	9066368			
Air outlet grid BMA	9066411	9060750	9060751	9060752	9060753				
Air inlet grid GRAG	9066431	9060764	9060765	9060766	9060767				
Air inlet grid GRAP	9066421	9060760	9060761	9060762	9060763				
Air inlet spigot plenum PRC	9066461	9066462	9066463	9066465	9066467	9066468			
Intake grid with filter (to be used in combination with inlet flange 90°) GRAFP	9066391	9060770	9060771	9060772	9060773				
Intake grid with filter (to be used in combination with straight inlet flange) GRAFG	9066401	9060774	9060775	9060776	9060777				
Silencer Plenum BXS	-	-	9069081	9069082	9069083				
Hotel box kit for concealed installation for horizontal model (frontal return and air supply) CHK	-	-	9066783	9066785	9066787	-	-		

Dimensions

YFCN/YFCN-ECM 130 to 940 (with casing)



VC, VCB and HC models

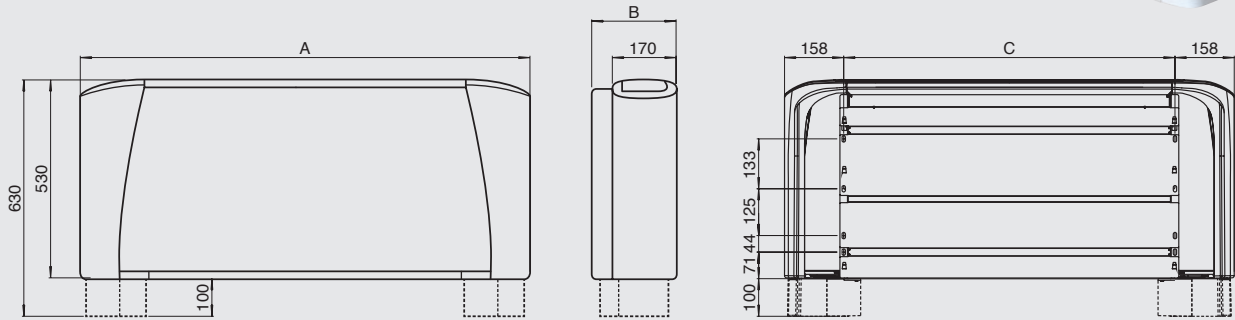

All dimensions in mm. Drawings not a scale.

Model	130 / 140	230 / 240	330 / 340	430 / 440	530 / 540	630 / 640	730 / 740	830 / 840	930 / 940
A	670	770	985	985	1 200	1 200	1 415	1 415	1 415
B	225	225	225	225	225	225	225	255	255
C	354	454	669	669	884	884	1 099	1 099	1 099

YFCN/YFCN-ECM 130 to 940 (without casing)

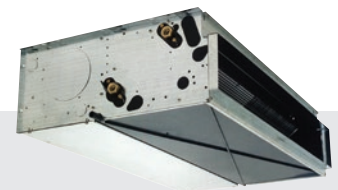

CD models

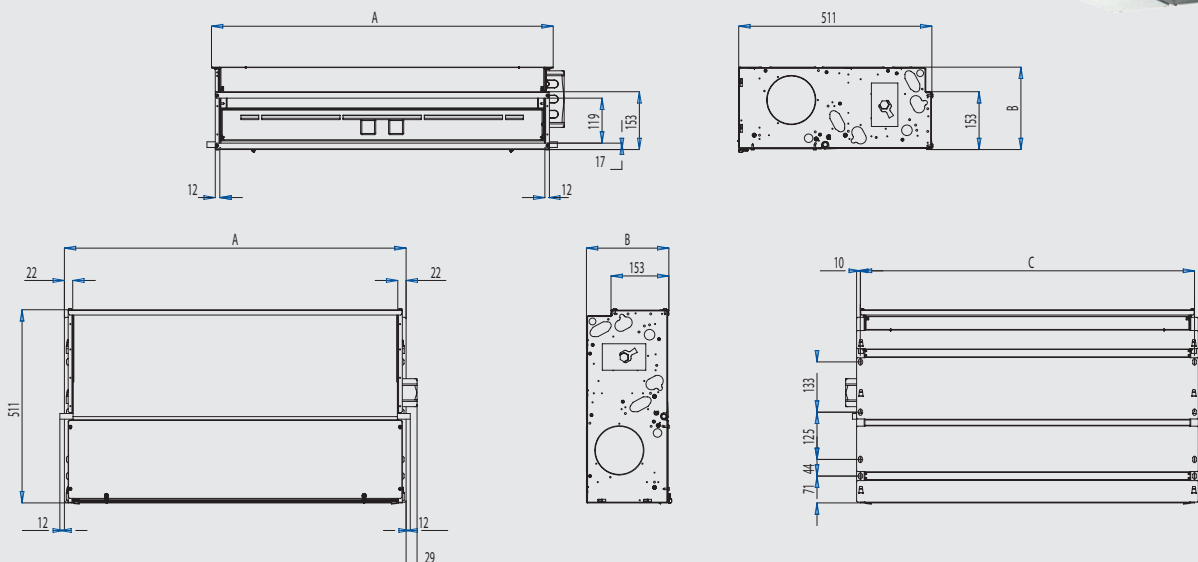

All dimensions in mm. Drawings not a scale.

Model	130 / 140	230 / 240	330 / 340	430 / 440	530 / 540	630 / 640	730 / 740	830 / 840	930 / 940
A	374	474	689	689	904	904	1 119	1 119	1 119
B	218	218	218	218	218	218	218	248	248
C	354	454	669	669	884	884	1 099	1 099	1 099

YFTS-ECM

Fan Coil Unit inverter with tangential fan

2 pipe system

A complete range from 0.4 kW to 3.81 kW



The YFTS-ECM fan coil unit combines a reduced dimension with a modern aesthetic, while maintaining great performances in terms of sound and consumption.

YFTS-ECM includes the VC version for wall installation and the CDV version for concealed installation; the VC version combines a reduced dimension, until 126 mm depth only, with a modern aesthetic that perfectly suits with any kind of furnishing, while maintaining great performances in terms of sound and consumption.



Selection software

Wired controls

T9000 Series

Red Dot Product Design Award Winner 2020

- Touch Screen Display
- 2 or 4 pipes FCU
- 3-speed motors or ECM motors
- 2-wiring/3-wiring on/off valves or proportional valves
- Relay designed for 100,000 switching cycles
- Modbus or BACnet protocols



T7600 Series

- LCD Screen Display
- 2 or 4 pipes FCU
- On/off or proportional
- 3-speed motors or ECM motors
- Modbus RTU



Infrared control



TUC03+ Terminal unit controller

BacNET and N2 Metasys network compatible



Features

- Modern casing, improved aesthetics, suitable for any modern indoor ambient
- Full range for all needs: 5 sizes suitable for vertical mounting with or without casing
- Low noise operation
- 3 fan speeds (possible choice between 6 fan speeds)
- EC motor with inverter at low energy consumption
- Breeze frame kit and recessed box for wall concealed installation in option
- Factory fitted 2 or 3 way valve (on/off) and controller packages
- Fan assembly made of plastic
- Tangential fan with anti-vibration fins
- 2 available versions in all range:
 - VC = Vertical Discharge with Casing
 - CDV = Concealed unit without Casing
- EUROVENT Certified

YFTS-ECM Fan Coil Unit inverter with tangential fan

0.4 kW to 3.81 kW



ECM the Energy Saving Technology

Brushless motor with inverter managed by dedicated controls. It permits to maintain extremely low electrical absorption and a continuous modulation of the air flow.

Technical features

YFTS-ECM model (2 pipes)		10	20	30	40	50	
Total cooling capacity [kW]	(1)	max	0.92	1.62	2.61	3.36	3.81
		med	0.66	1.15	1.91	2.50	2.92
		min	0.40	0.67	0.92	1.14	1.44
Sensible cooling capacity [kW]	(1)	max	0.75	1.28	1.99	1.99	2.83
		med	0.52	0.88	1.41	1.41	2.10
		min	0.30	0.50	0.67	0.67	1.04
Pressure drop in cooling [kPa]	(1)	max	14.7	7.4	18.6	39.1	16.9
		med	9.1	4.9	11.5	23.7	11.2
		min	4.9	3.1	4.5	7.3	4.6
Heating capacity [kW]	(2)	max	1.10	1.81	2.90	3.62	4.20
		med	0.78	1.32	2.10	2.58	3.00
		min	0.55	0.97	1.52	1.79	2.19
Pressure drop in heating [kPa]	(2)	max	16.2	7.3	18.2	36.2	16.2
		med	9.6	5.0	11.0	20.6	9.7
		min	6.1	3.7	7.1	11.7	6.4
Air flow [m³/h]		max	205	305	470	575	645
		med	130	205	315	380	430
		min	75	125	190	220	255
Fan [W]		max	10.3	14.0	21.6	25.4	29.5
		med	5.2	6.3	8.6	9.9	11.4
		min	3.2	3.7	4.1	4.7	5.3
Sound power level [dB(A)]		max	50	52	53	55	55
		med	40	42	43	45	46
		min	31	30	32	33	34
Sound pressure level [dB(A)]	(3)	max	41	43	44	46	46
		med	31	33	34	36	37
		min	22	21	23	24	25
Power supply [V-ph-Hz]		230 / 1 / 50 + E					
Dimensions *	Height	mm	580	580	580	580	580
	Width	mm	640	840	1040	1240	1440
	Depth	mm	126	126	126	126	126
Weight *		kg	10.1	13.2	16.4	19.6	23.0

(1) Room temperature 27°C d.b., 19°C w.b. - Water temperature 7/12 °C.

(2) Room temperature 20°C - Water temperature 45/40 °C.

(3) The sound pressure levels are 9 dB(A) lower than the sound power levels and apply to the reverberant field of a 100 m³ room and a reverberation time of 0.5 sec.

* Dimensions refer to the units with casing. Feet not included.



Manufacturer reserves the rights to change specifications without prior notice.

YFTS-ECM

Fan Coil Unit inverter with tangential fan

Compatibility tables



Model YFTS-ECM	10	20	30	40	50
Accessories (supplied loose)					
Feet PAP-F			9071074		
Breeze frame kit for wall concealed installation CBF-A	-	9071162	-	-	-
Breeze frame kit for wall concealed installation CBF-B	-	-	9071163	-	-
Breeze frame kit for wall concealed installation CBF-C	-	-	-	9071164	-
Recessed box for wall concealed installation IBF 2	-	9071152	-	-	-
Recessed box for wall concealed installation IBF 3	-	-	9071153	-	-
Recessed box for wall concealed installation IBF 4	-	-	-	9071154	-
2 way valve ON-OFF 230 V with electric motor and mounting kit			9071090		
3 way water valve ON-OFF 230 V and mounting kit			9071091		
Controls for YFTS-ECM models					
CB-E control fitted on the unit (1)			9071060		
CB-Touch control fitted on the unit (2)			9071061		
Automatic speed control with electronic thermostat and S/W switch - JWC-AU (to be used with UPM-AU and UP-AU only) (3) (4)			9066632K		
Automatic remote control with electronic thermostat, S/W switch and liquid crystal display T-MB (to be used with UPM-AU and UP-AU only) (3) (4)			9066331E		
UP-ECO power unit for CB-E control			9071064		
UP-Touch power unit for CB-Touch, JWC-AU and T-MB controls			9071065		
WM-503-AC-ECM Continuous fan speed control with electronic thermostat, summer/winter switch and LCD display			9066686		
Power unit UPM-AU for JWC-AU and T-MB remote controls, fitted on the unit			9066641		
Power unit UP-AU for JWC-AU and T-MB remote controls, not fitted on the unit			9066640		
UP-503-AC-EC Power unit for WM-503-AC-EC control			9066687		
KIT 503-KNX Mounting kit for power unit UP-503-AC-EC			9071076		
T2 sensor (to be used as Change-over or minimum temperature Sensor)			9025310		

- (1) The control must always be connected with UP-ECO power unit (separately delivered).
- (2) The control must always be connected with UP-Touch power unit (separately delivered).
- (3) Can be used with valves and/or low temperature cut-out.
- (4) Can be used with Change Over.



CB-E control fitted on the unit

- Set the unit ON or stand-by
- Set the fan speed
- Fan OFF and valve closing when the SETPOINT selected with the centralized thermostat (programmable thermostat) is reached.
- Button lock controller and regulation of LED brightness



CB-Touch control fitted on the unit

- Set the unit ON or stand-by
- Operation mode (Summer/Winter/Ventilation)
- Set the fan speed / automatic fan speed
- Possibility to use the T1 sensor as return air probe (mounted on the power unit)
- Possibility to use the T3 sensor as low temperature cut-out thermostat (mounted on the power unit)
- It allows to use the T2 sensor as Change-over (mounted on the power unit).
- Night mode, Alarm messages, OFFSET regulation
- Button lock controller and regulation of LED brightness

Dimensions

YFCN/YFCN-ECM 130 to 940 (with casing)

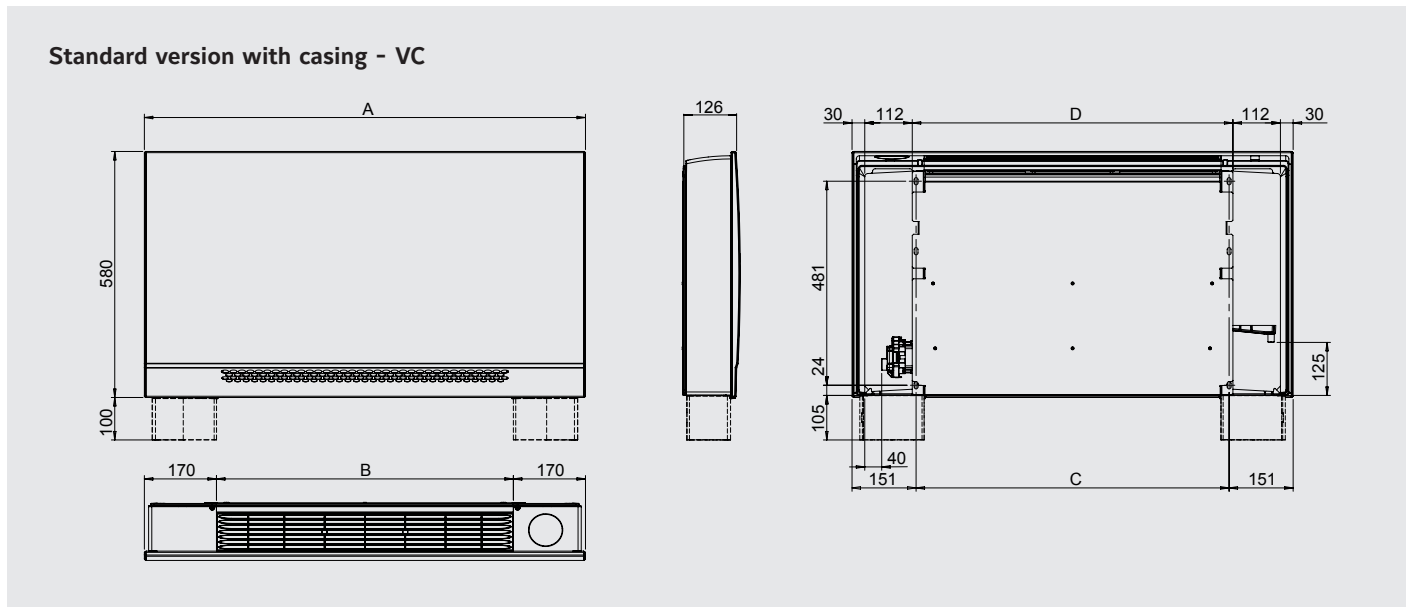

All dimensions in mm. Drawings not a scale.

YFCN/YFCN-ECM 130 to 940 (without casing)

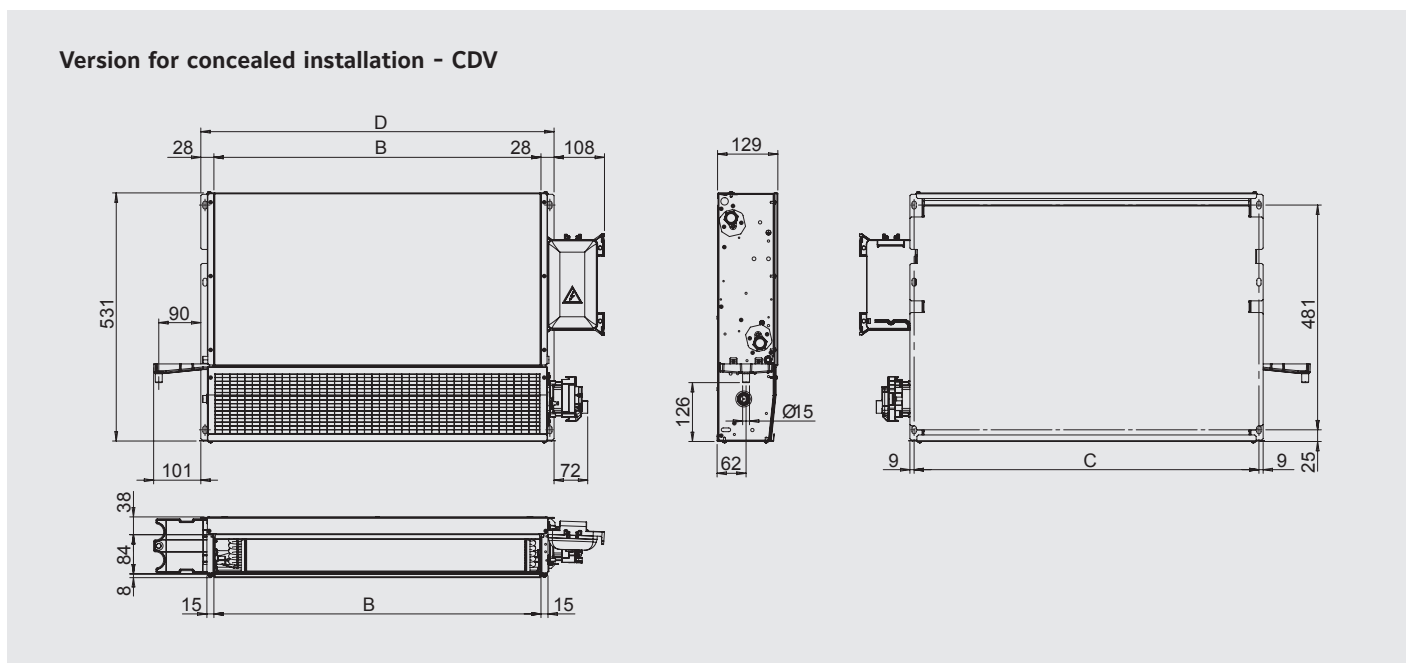

All dimensions in mm. Drawings not a scale.

Model	10	20	30	40	50
A	640	840	1040	1240	1440
B	300	500	700	900	1100
C	338	538	738	938	1138
D	356	556	756	956	1156

LASER and LOW BODY Fan Coil Units

2 and 4 pipe system

A complete range from 0.6 kW up to 9.7 kW



TUC03+ Terminal unit controller
BacNET and N2 Metasys network compatible



**CSL00 (Built in)
CSR00 (Wall mounted)**
Fan speed selector



**CML00 (Built in)
CMR00 (Wall mounted)**
Thermostat with manual fan speed and S/W change over



**CEL00 (Built in)
CER00 (Wall mounted)**
Thermostat with manual fan speed and automatic change over

**CEL20 (Built in)
CER20 (Wall mounted)**
Thermostat with auto. fan speed and automatic change over

**CEL30 (Built in)
CER30 (Wall mounted)**
Thermostat with auto. fan speed and automatic change over for modulating valve

LASER fan coil units are simple and elegant, discreet in their design. High standards of quality and reliability, combined with a wide range of accessories ensure a total solution for all comfort cooling and heating requirements.

LOW BODY units are part of the LASER Fan Coils Units family. The reduced height cabinet makes them the ideal solution for new or replacement applications where dimensional limitations apply.

Features

- 6 speed fan
- Cabinet factory fitted
- Valve factory fitted
- Electrical heater factory fitted
- Thermal or modulating valve
- Service valve
- Option front air intake (LASER)
- Optional plenum (LASER)
- ECM inverter option available
- Option for district cooling coil
- EUROVENT Certified



Selection software

LASER and LOW BODY Fan Coil Units

0.6 kW to 9.7 kW



Technical features

Model		LASER: YLV, YLV-AF, YLH, YLH-AF, YLIV, YLIV-AF, YLIH, YLIH-AF										
Sizes		110	112	114	216	218	220	222	224	226	328	
Total cooling capacity [kW]	(1)	max	1.11	1.59	2.14	3.30	3.50	4.44	5.07	6.43	7.25	9.73
		med	0.95	1.31	1.88	2.67	2.99	3.68	4.39	5.75	6.67	8.75
		min	0.76	1.07	1.57	2.20	2.46	2.94	3.84	4.62	5.50	6.36
Sensible cooling capacity [kW]	(1)	max	0.93	1.25	1.90	2.46	3.06	3.53	4.42	5.06	5.70	8.04
		med	0.78	0.99	1.64	1.95	2.51	2.84	3.74	4.44	5.18	7.15
		min	0.61	0.79	1.33	1.56	2.00	2.20	3.20	3.45	4.15	5.03
Water flow in cooling [l/h]	(1)	max	191	274	368	568	602	764	873	1107	1248	1675
		med	164	225	324	460	515	633	756	990	1148	1506
		min	131	184	270	379	423	506	661	795	947	1095
Pressure drop in cooling [kPa]	(1)	max	3.4	7.1	5.8	14.8	13.6	24.1	28.4	18.8	21.0	74.6
		med	2.8	5.0	4.6	12.5	9.8	17.4	21.8	15.5	18.1	61.5
		min	2.0	3.4	3.3	8.5	6.7	11.6	17.2	10.5	12.8	30.8
Heating capacity 2 pipes [kW]	(2)	max	1.37	1.83	2.60	3.46	4.17	4.80	6.04	6.60	7.86	10.54
		med	1.13	1.46	2.07	2.90	3.51	3.89	5.11	5.84	7.17	9.64
		min	0.87	1.14	1.70	2.31	2.83	3.01	4.41	4.58	5.76	6.73
Water flow in heating 2 pipes [l/h]	(2)	max	236	315	448	596	718	826	1040	1136	1353	1814
		med	194	251	356	499	604	669	879	1004	1233	1658
		min	150	196	292	397	487	518	759	788	991	1158
Pressure drop in heating 2 pipes [kPa]	(2)	max	4.9	6.0	6.5	14.7	16.0	23.4	27.7	18.9	25.3	82.4
		med	4.6	6.0	5.1	10.5	11.7	16.3	21.1	15.3	21.6	67.7
		min	3.0	4.1	4.0	6.9	8.1	10.8	16.4	10.3	14.9	29.7
Heating capacity 4 pipes [kW]	(3)	max	0.91	1.31	1.93	2.79	3.20	4.33	4.92	6.16	6.30	8.00
		med	0.83	1.13	1.85	2.40	2.81	3.67	4.33	5.55	5.98	7.43
		min	0.71	0.95	1.51	2.06	2.38	2.99	3.84	4.55	5.03	5.83
Water flow in heating 4 pipes [l/h]	(3)	max	78	113	166	240	275	373	423	530	542	688
		med	71	97	159	207	242	316	373	478	515	639
		min	61	82	130	177	205	257	330	391	433	501
Pressure drop in heating 4 pipes [kPa]	(3)	max	1.3	3.4	6.7	14.7	7.1	10.3	11.7	33.0	31.7	46.5
		med	1.1	2.6	5.8	10.5	5.7	7.7	9.5	23.0	28.9	40.6
		min	0.9	1.8	5.2	9.4	4.0	5.4	7.7	16.3	21.4	24.7
Air flow [m ³ /h]		max	243	317	432	606	754	961	1115	1307	1507	2010
		med	181	253	352	488	616	776	928	1106	1318	1687
		min	136	185	279	377	486	594	742	779	986	1107
Sound power level [dB(A)]		max	48	50	54	53	55	54	60	60	63	67
		med	42	45	49	47	50	48	56	55	60	63
		min	36	38	42	40	43	40	50	47	53	52
Sound pressure level [dB(A)]	(4)	max	39	41	45	44	46	45	51	51	54	58
		med	33	36	40	38	41	39	47	46	51	54
		min	27	29	33	31	34	31	40	38	44	43
Power supply [V-ph-Hz]		230 / 1 / 50 + E										
Power input [W]	max	46	48	57	61	76	90	117	140	162	213	
Absorbed current [A]	max	0.21	0.21	0.25	0.27	0.33	0.39	0.52	0.64	0.71	0,95	
Dimensions	Height	mm	538	538	538	538	538	614	614	614	614	614
	Width	mm	648	773	898	1023	1148	1273	1273	1523	1523	1773
	Depth	mm	224	224	224	224	224	254	254	254	254	254

(1) Room temperature 27°C d.b., 19°C w.b. - Water temperature 7/12 °C

(2) Room temperature 20°C - Water inlet temperature: 45/40°C

(3) Room temperature 20°C - Water inlet temperature: 65/55°C.

(4) Sound pressure level in a 100 m³ room, at 1.5 m distance and riverberating time of 0.3 s. max = speed 2, med = speed 3, min = speed 5 when using selection software



Manufacturer reserves the rights to change specifications without prior notice.

LASER and LOW BODY Fan Coil Units

0.6 kW to 9.7 kW



Technical features

Model		LOW BODY: YLVR, YLIVR					
Sizes		110	112	114	216	218	
Total cooling capacity [kW]	(1)	max	0.98	1.21	1.87	2.74	3.23
		med	0.81	1.02	1.61	2.35	2.81
		min	0.64	0.80	1.37	1.84	2.37
Sensible cooling capacity [kW]	(1)	max	0.90	1.09	1.62	2.32	2.71
		med	0.73	0.92	1.39	1.97	2.34
		min	0.56	0.71	1.15	1.54	1.95
Water flow in cooling [l/h]	(1)	max	166	207	318	519	614
		med	139	175	274	442	531
		min	109	137	233	346	446
Pressure drop in cooling [kPa]	(1)	max	2.5	3.5	8.4	7.1	10.2
		med	1.9	2.6	6.5	5.4	7.9
		min	1.3	1.8	5.0	3.6	5.9
Heating capacity 2 pipes [kW]	(2)	max	1.18	1.53	2.22	3.16	3.78
		med	0.95	1.29	1.9	2.67	3.25
		min	0.76	1.02	1.58	2.18	2.71
Water flow in heating 2 pipes [l/h]	(2)	max	204	265	384	595	717
		med	163	224	328	501	612
		min	130	176	273	405	506
Pressure drop in heating 2 pipes [kPa]	(2)	max	2.5	4.2	9.3	7.3	11.8
		med	1.7	3.2	7.1	5.4	8.9
		min	1.2	2.1	5.2	3.7	6.4
Heating capacity 4 pipes [kW]	(3)	max	1.12	1.79	1.87	2.54	3.83
		med	0.93	1.54	1.65	2.22	3.37
		min	0.77	1.25	1.42	1.89	2.88
Water flow in heating 4 pipes [l/h]	(3)	max	98	157	165	224	338
		med	81	135	145	196	297
		min	68	109	125	167	254
Pressure drop in heating 4 pipes [kPa]	(3)	max	1.8	4.8	6.5	11.8	5.9
		med	1.3	3.7	5.2	9.4	4.7
		min	1.0	2.5	4.0	7.1	3.6
Air flow [m ³ /h]		max	243	317	432	606	754
		med	181	253	352	488	616
		min	136	185	279	377	486
Sound power level [dB(A)]		max	47	50	53	51	55
		med	41	44	49	45	50
		min	34	38	42	39	43
Sound pressure level [dB(A)]	(4)	max	37	40	44	42	46
		med	31	35	39	36	41
		min	25	29	33	29	34
Power supply [V-ph-Hz]		230 / 1 / 50 + E					
Power input [W]	max	46	48	57	61	76	
Absorbed current [A]	max	0.21	0.21	0.25	0.27	0.33	
Dimensions	Height	mm	430	430	430	430	430
	Width	mm	648	773	898	1023	1148
	Depth	mm	254	254	254	254	224

(1) Room temperature 27°C d.b., 19°C w.b. - Water temperature 7/12 °C

(2) Room temperature 20°C - Water inlet temperature: 45/40°C

(3) Room temperature 20°C - Water inlet temperature: 65/55°C.

 (4) Sound pressure level in a 100 m³ room, at 1.5 m distance and riverberating time of 0.3 s. max = speed 2, med = speed 3, min = speed 5 when using selection software

Manufacturer reserves the rights to change specifications without prior notice.

Options/Accessories

Compatibility table / Codes

Model		LASER										LOW BODY				
Sizes		110	112	114	216	218	220	222	224	226	328	110	112	114	216	218
With Cabinet																
YLV-YLH	2/3/4 rows	•	•	•	•	•	•	•	•	•	•					
YLV-YLH/AF Front air intake	2/3/4 rows	•	•	•	•	•	•	•	•	•	•					
YLVR	2/3 rows											•	•	•	•	•
Without Cabinet																
YLIV-YLIH	2/3/4 rows	•	•	•	•	•	•	•	•	•	•					
YLIV-YLIH/AF Front air intake	2/3/4 rows	•	•	•	•	•	•	•	•	•	•					
YLIVR	2/3 rows											•	•	•	•	•
Options (Factory fitted)																
Coil and heaters																
1 row heating	BA1	•	•	•	•	•	•	•	•	•	•	•	•	•	•	•
Kit electrical heater (with relay and safety switch)	KREL	•	•	•	•	•	•	•	•	•	•	•	•	•	•	•
Built in thermostat																
Fan speed selector	CSL00										•					
Thermostat with manual fan speed and S/W change over	CML00										•					
Thermostat with manual fan speed, dead band, automatic change over	CEL00										•					
Thermostat with automatic fan speed, dead band, automatic change over	CEL20										•					
Thermostat with automatic fan speed, dead band, automatic change over for modulating valve	CEL30										•					
Parallel connection																
For ON/OFF valve one/FCU	CBL20										•					
For modulating valve one/FCU	CBL30										•					
3 way valve factory fitted																
For 2 pipe systems ON/OFF	J3A2 (2p)										•					
For 4 pipe systems ON/OFF	J3A2 (4p)										•					
3 way modulating valve factory fitted																
For 2 pipe systems Modulating	J3AM (2p)										•					
For 4 pipe systems Modulating	J3AM (4p)										•					
Shut off valves factory fitted																
For 2 pipe systems	DT (2p)										•					
For 4 pipe systems	DT (4p)										•					
Condensate pump	PC										•					
WS sensor change over for CEL/CER	WS										•					
Minimum temperature thermostat	TM										•					
Accessories (Supplied loose)																
Remote controllers and thermostat (wall mounted)																
Fan speed selector	CSR00										•					
Thermostat with manual fan speed and S/W change over	CMR00										•					
Thermostat with manual fan speed, dead band, automatic change over	CER00										•					
Thermostat with automatic fan speed, dead band, automatic change over	CER20										•					
Thermostat with automatic fan speed, dead band, automatic change over for modulating valve	CER30										•					
Feet and panel (1)																
Set of painted feet	CP1	•	•	•	•	•	•	•	•	•	•	•	•	•	•	•
Set of painted feet + frontal socle	ZL1	•	•	•	•	•	•	•	•	•	•	•	•	•	•	•
Vertical painted back panel	PPV1	•	•	•	•	•	•	•	•	•	•	•	•	•	•	•
Horizontal painted back panel	PPH1	•	•	•	•	•	•	•	•	•	•	•	•	•	•	•
Plenums and air intake (1)																
Air intake plenum	PA	•	•	•	•	•	•	•	•	•	•	•	•	•	•	•
Air intake plenum with collars	PAS	•	•	•	•	•	•	•	•	•	•	•	•	•	•	•
90° air intake plenum	PA90	•	•	•	•	•	•	•	•	•	•	•	•	•	•	•
Air intake duct fitting	RCA	•	•	•	•	•	•	•	•	•	•	•	•	•	•	•
Air delivery plenum with collars	PM	•	•	•	•	•	•	•	•	•	•	•	•	•	•	•
90° air delivery plenum	PM90	•	•	•	•	•	•	•	•	•	•	•	•	•	•	•

(1) for check compatibility with the models of FCU see compatibility table

Dimensions and Weights

- | | | |
|---|--|---|
| YLV and YLH <ul style="list-style-type: none"> V = vertical H = horizontal | YLV-AF and YLH-AF <ul style="list-style-type: none"> AF = front air intake V = vertical H = horizontal | YLV-R <ul style="list-style-type: none"> R= low body V= vertical |
|---|--|---|

LASER: YLV - YLV/AF

VERTICAL

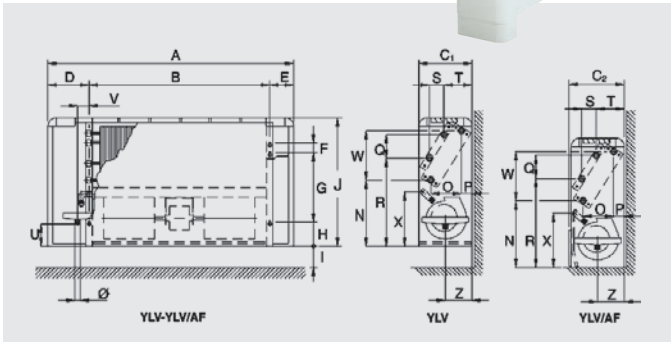

LASER: YLH - YLH/AF

HORIZONTAL

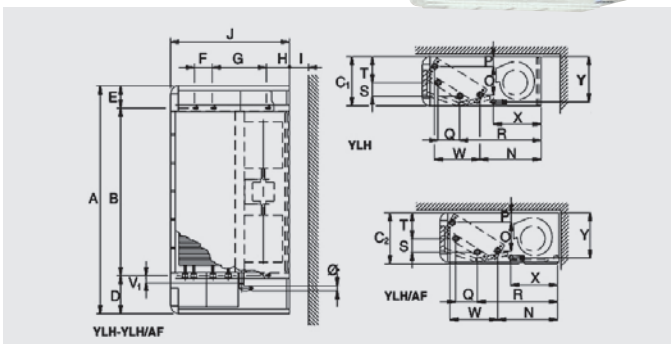

LOW BODY: YLV-R

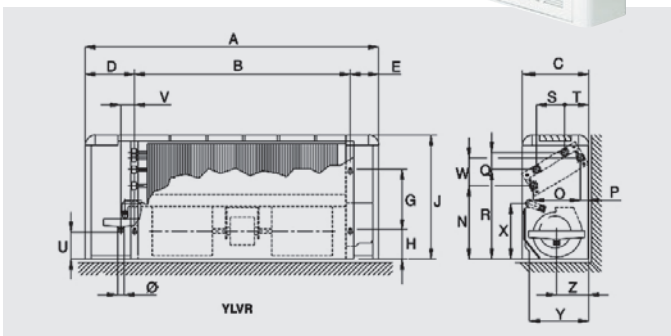

Dim	110	112	114	216	218	220	222	224	226	328
A	648	773	898	1023	1148	1273	1273	1523	1523	1773
B	374	499	624	749	874	999	999	1249	1249	1499
C1	224	224	224	224	224	254	254	254	254	254
C2	233	233	233	233	233	263	263	263	263	263
D	174	174	174	174	174	174	174	174	174	174
E	100	100	100	100	100	100	100	100	100	100
F	40	40	40	40	40	40	40	40	40	40
G	280	280	280	280	280	356	356	356	356	356
H	101	101	101	101	101	101	101	101	101	101
I	85	85	85	85	85	85	85	85	85	85
J	538	538	538	538	538	614	614	614	614	614
N	266	266	266	266	266	299	299	299	299	299
O	113	113	113	113	113	138	138	138	138	138
P	48	48	48	48	48	53	53	53	53	53
Q	87	87	87	87	87	87	87	87	87	87
R	355	355	355	355	355	409	409	409	409	409
S	50	50	50	50	50	50	50	50	50	50
T	117	117	117	117	117	135	135	135	135	135
U	90	90	90	90	90	116	116	116	116	116
V	47	47	47	47	47	47	47	47	47	47
V1	28	28	28	28	28	28	28	28	28	28
W	195	195	195	195	195	238	238	238	238	238
X	219	219	219	219	219	252	252	252	252	252
Y	205	205	205	205	205	235	235	235	235	235
Z	109	109	109	109	109	122	122	122	122	122
∅	20	20	20	20	20	20	20	20	20	20
kg1	18	20	23	28	31	41	44	52	52	58
kg2	19	21	24	30	32	43	46	54	54	61

Notes: 1=YLV / YLH - 2=YLV/AF / YLH/AF (All dimensions in mm)

Dim	110	112	114	216	218
A	648	773	898	1023	1148
B	374	499	624	749	874
C	254	254	254	254	254
D	174	174	174	174	174
E	100	100	100	100	100
G	170	170	170	170	170
H	101	101	101	101	101
J	430	430	430	430	430
N	245	245	245	245	245
O	154	154	154	154	154
P	31	31	31	31	31
Q	47	47	47	47	47
R	304	304	304	304	304
S	88	88	88	88	88
T	87	87	87	87	87
U	65	65	65	65	65
V	47	47	47	47	47
W	84	84	84	84	84
X	214	214	214	214	214
Z	109	109	109	109	109
∅	20	20	20	20	20
kg	15	17	22	23	26

(All dimensions in mm)

Dimensions & Weights

YLIV and YLIH

- V = vertical
- H = horizontal
- I = without cabinet

YLIV-AF and YLIH-AF

- AF = front air intake
- V = vertical
- H = horizontal
- I = without cabinet

YLIVR

- R = low body
- V = vertical
- I = without cabinet

LASER: YLIV - YLIV/AF

VERTICAL

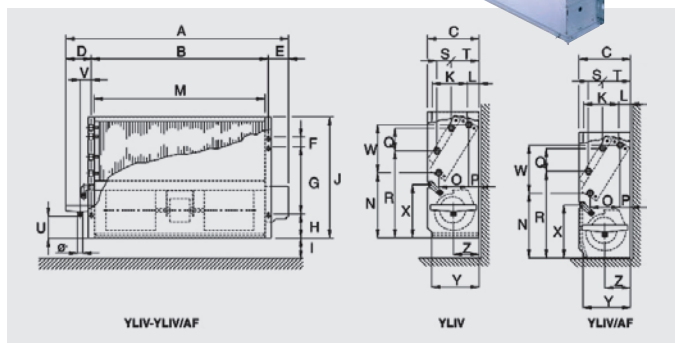
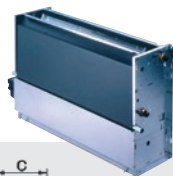

LASER: YLIH - YLIH/AF

HORIZONTAL

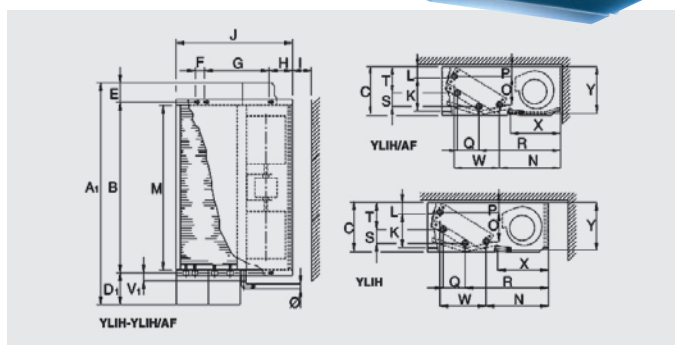
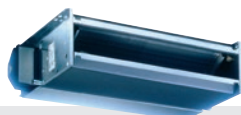

LOW BODY: YLIVR

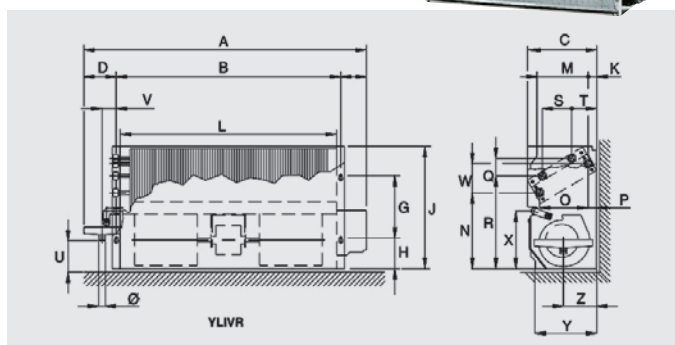

Dim	110	112	114	216	218	220	222	224	226	328
A	555	680	805	930	1055	1180	1180	1430	1430	1680
A1	574	699	824	949	1074	1199	1199	1449	1449	1699
B	374	499	624	749	874	999	999	1249	1249	1499
C	215	215	215	215	215	245	245	245	245	245
D	109	109	109	109	109	109	109	109	109	109
D1	128	128	128	128	128	128	128	128	128	128
E	72	72	72	72	72	72	72	72	72	72
F	40	40	40	40	40	40	40	40	40	40
G	280	280	280	280	280	356	356	356	356	356
H	101	101	101	101	101	101	101	101	101	101
I	85	85	85	85	85	85	85	85	85	85
J	505	505	505	505	505	581	581	581	581	581
K	110	110	110	110	110	125	125	125	125	125
L	55	55	55	55	55	60	60	60	60	60
M	349	474	599	724	849	974	974	1224	1224	1474
N	266	266	266	266	266	299	299	299	299	299
O	113	113	113	113	113	138	138	138	138	138
P	48	48	48	48	48	53	53	53	53	53
Q	87	87	87	87	87	87	87	87	87	87
R	355	355	355	355	355	409	409	409	409	409
S	50	50	50	50	50	50	50	50	50	50
T	117	117	117	117	117	135	135	135	135	135
U	90	90	90	90	90	116	116	116	116	116
V	47	47	47	47	47	47	47	47	47	47
V1	28	28	28	28	28	28	28	28	28	28
W	195	195	195	195	195	238	238	238	238	238
X	219	219	219	219	219	252	252	252	252	252
Y	200	200	200	200	200	230	230	230	230	230
Z	109	109	109	109	109	122	122	122	122	122
∅	20	20	20	20	20	20	20	20	20	20
kg	10	13	16	19	22	29	31	38	38	42

(All dimensions in mm)

Dim	110	112	114	216	218
A	555	680	805	930	1055
B	374	499	624	749	874
C	230	230	230	230	230
D	108	108	108	108	108
E	73	73	73	73	73
G	170	170	170	170	170
H	101	101	101	101	101
J	395	395	395	395	395
K	61	61	61	61	61
L	349	474	599	724	849
M	127	127	127	127	127
N	245	245	245	245	245
O	154	154	154	154	154
P	31	31	31	31	31
Q	47	47	47	47	47
R	304	304	304	304	304
S	88	88	88	88	88
T	87	87	87	87	87
U	65	65	65	65	65
V	47	47	47	47	47
W	84	84	84	84	84
X	214	214	214	214	214
Y	201	201	201	201	201
Z	109	109	109	109	109
∅	20	20	20	20	20
kg	9	11	14	16	19

(All dimensions in mm)

LASER and LOW BODY Fan Coil Units

Compatibility tables



**CSL00 (Built in)
CSR00 (Wall mounted)**
Fan speed selector



**CEL00 (Built in)
CER00 (Wall mounted)**
Thermostat with manual fan speed and automatic change over



**CML00 (Built in)
CMR00 (Wall mounted)**
Thermostat with manual fan speed and S/W change over

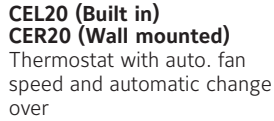

**CEL20 (Built in)
CER20 (Wall mounted)**
Thermostat with auto. fan speed and automatic change over

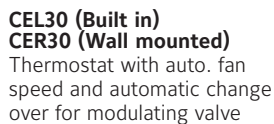

**CEL30 (Built in)
CER30 (Wall mounted)**
Thermostat with auto. fan speed and automatic change over for modulating valve

Features CEL/CER

- Dead band for change over 5°C or 2°C (factory set 2°C)
- Manual fan speeds or automatic (models 20 and 30)
- Thermostated fan control or continuous fan running
- Option water sensor WS for change over on coil (for 2 pipes)
- Led indicated status summer, winter or dead band
- Temperature setting for 7 to 30°C (comfort 20–25°C)
- Plastic pins for limiting temperature range
- Input for window contact
- Input for Economy/ occupancy mode
- Output for remote alarm
- Filter alarm 600 or 1200 running hours (factory set 1200 hours)
- With electrical heater post ventilation
- With Air sensor in the air intake destratification function (CEL only)

Compatibility table Thermostats / Valves / Heaters / Parallel connection / Water sensor / Minimum temperature thermostat

Factory fitted thermostat (built in)		Valves for 2 pipes		Valves for 4 pipes		Heaters	Parallel connection		Water sensor	Min. Temp. Thermostat
		J3A2 (2p)	J3AM (2p)	J3A2 (4p)	J3AM (4p)		ON/OFF	Modulating		
CSL00	Fan speed selector						•			•
CML00	Thermostat with manual fan speed and S/W change over	•		•			•			•
CEL00	Thermostat with manual fan speed, dead band, automatic change over	•		•		•	•		•	•
CEL20	Thermostat with automatic fan speed, dead band, automatic change over	•		•		•	•		•	•
CEL30	Thermostat with automatic fan speed, dead band, automatic change over for modulating valve		•		•			•	•	•
Remote controllers and thermostats (wall mounted)										
CSR00	Fan speed selector						•			•
CMR00	Thermostat with manual fan speed and S/W change over	•		•			•			•
CER00	Thermostat with manual fan speed, dead band, automatic change over	•		•		•	•		•	•
CER20	Thermostat with automatic fan speed, dead band, automatic change over	•		•		•	•		•	•
CER30	Thermostat with automatic fan speed, dead band, automatic change over for modulating valve		•		•			•	•	•

• Compatible Not compatible

LASER and LOW BODY Fan Coil Units

Compatibility tables



Compatibility Options / Accessories / Models

Code		Designation	STANDARD								LOW BODY	
			LASER				CONCEALED				YLVR	YLIVR
			YLV	YLH	YLV-AF	YLH-AF	YLIV	YLH	YLIV-AF	YLH-AF		
Coils and heaters**												
BA1**	Additional 1 row heating		•	•	•	•	•	•	•	•	•	•
KREL**	Kit electrical heater with safety thermostat and relay		•	•	•	•	•	•	•	•		
Factory fitted thermostat (built in)												
CSL00	Fan speed selector (built in)		•		•		•		•		•	•
CML00	Thermostat with manual fan speed and S/W change over		•		•		•		•		•	•
CEL00	Thermostat with manual fan speed, dead band, automatic change over		Compatible with electrical heaters								•	•
CEL20	Thermostat with automatic fan speed, dead band, automatic change over		Compatible with electrical heaters								•	•
CEL30	Thermostat with automatic fan speed, dead band, automatic change over for modulating valves		•		•		•		•		•	•
CBL20	Parallel connection for ON/OFF valve		•	•	•	•	•	•	•	•	•	•
CBL30	Parallel connection for modulating valve		•	•	•	•	•	•	•	•	•	•
Remote controllers and thermostats (wall mounted)												
CSR00	Fan speed selector (wall mounted)		•	•	•	•	•	•	•	•	•	•
CMR00	Thermostat with manual fan speed and S/W change over		•	•	•	•	•	•	•	•	•	•
CER00	Thermostat with manual fan speed, dead band, automatic change over		Compatible with electrical heaters								•	•
CER20	Thermostat with automatic fan speed, dead band, automatic change over		Compatible with electrical heaters								•	•
CER30	Thermostat with automatic fan speed, dead band, automatic change over for modulating valves		•	•	•	•	•	•	•	•	•	•
Valves / Condensate pump / Water sensor / Minimum temperature thermostat (Factory fitted)												
J3A2 (2p)	3-way 4-ports on/off valves for 2-pipe systems		•	•	•	•	•	•	•	•	•	•
J3A2 (4p)	3-way 4-ports on/off valves for 4-pipe systems		•	•	•	•	•	•	•	•	•	•
J3AM (2p)	3-way 4-ports modulating valves for 2-pipe systems		•	•	•	•	•	•	•	•	•	•
J3AM (4p)	3-way 4-ports modulating valves for 4-pipe systems		•	•	•	•	•	•	•	•	•	•
DT (2p)	Shut-off valves for 2-pipe systems (in addition to J3A2/J3AM valves)		•	•	•	•	•	•	•	•	•	•
DT (4p)	Shut-off valves for 4-pipe systems (in addition to J3A2/J3AM valves)		•	•	•	•	•	•	•	•	•	•
PC	Condensate pump		•	•	•	•	•	•	•	•	•	•
WS	Water sensor		Compatible with CEL/CER									
TM	Minimum temperature thermostat		•	•	•	•	•	•	•	•	•	•
Feet and panels												
CP1	Set of painted feet		•				•					
ZL1	Set of feet + frontal socle		•									
PPV1	Vertical painted back panel		•		•						•	
PPH1	Horizontal painted back panel			•		•						
External air intake												
PA	Air intake plenum							•				
PAS	Air intake plenum collars							•				
PA90	90° air intake plenum							•				
RCA	Air intake duct fitting							•				
PM	Air delivery plenum with collars						•	•	•	•		•
PM90	90° air delivery plenum						•	•	•	•		•

- Compatible
- Compatible with conditions
- Not compatible

** Maximum of rows is indicated in the documentation, the maximum number of rows includes the heating row or electrical heater.

LASER ECM and LOW BODY ECM Inverter Fan Coil Units

0.6 kW to 9.2 kW



ECM the Energy Saving Technology

Brushless motor with inverter managed by dedicated controls. It permits to maintain extremely low electrical absorption and a continuous modulation of the air flow.

Technical features

Model		LASER ECM							LOW BODY ECM			
Sizes	(*)	512	514	516	520	522	524	528	512	514	516	
Total cooling capacity [kW]	(1)	max ...v	1.98	2.56	3.81	5.05	5.81	7.47	9.18	1.56	2.37	3.40
		med ...v	1.43	1.81	2.53	3.86	4.42	5.64	6.94	1.18	1.78	2.34
		min ...v	0.74	0.93	1.51	2.72	3.05	4.07	4.89	0.61	1.29	1.53
Sensible cooling capacity [kW]	(1)	max	1.65	2.12	3.14	3.79	4.32	6.09	7.51	1.42	2.09	2.93
		med	1.16	1.48	2.01	2.78	3.16	4.42	5.50	1.04	1.54	1.96
		min	0.54	0.78	1.21	1.92	2.11	3.13	3.74	0.53	1.09	1.25
Water flow in cooling [l/h]	(1)	max	341	441	656	869	1000	1286	1580	265	404	644
		med	246	312	435	664	761	971	1194	200	304	440
		min	127	160	260	468	525	701	842	104	220	286
Pressure drop in cooling [kPa]	(1)	max	9.6	9.2	14.6	16.9	36.2	16.8	31.3	8.2	12.6	10.3
		med	5.4	4.8	8.5	10.6	22.0	10.0	18.5	5.1	7.8	5.4
		min	1.7	1.6	3.9	5.6	11.1	5.5	9.7	1.8	4.5	2.6
Heating capacity 2 pipes [kW]	(2)	max	2.05	3.04	4.40	5.76	6.53	8.43	10.4	2.07	2.85	4.00
		med	1.47	2.18	3.05	4.44	4.84	6.22	7.67	1.50	2.09	2.66
		min	0.78	1.15	1.87	3.11	3.37	4.50	5.38	0.8	1.49	1.77
Water flow in heating 2 pipes [l/h]	(2)	max	353	523	757	991	1124	1451	1790	358	495	763
		med	253	375	525	757	833	1071	1320	260	362	499
		min	134	198	322	535	580	775	926	138	258	325
Pressure drop in heating 2 pipes [kPa]	(2)	max	10.8	10.3	17.3	21.8	40.0	17.2	32.2	9.7	14.4	11.2
		med	6.0	5.5	8.6	13.0	23.5	9.8	18.0	5.6	8.4	5.3
		min	2.0	2.0	4.2	6.6	11.5	5.3	9.0	1.9	4.7	2.6
Heating capacity 4 pipes [kW]	(3)	max	1.84	2.39	3.20	5.00	5.55	6.46	7.90	2.19	2.29	3.06
		med	1.37	1.76	2.40	4.12	4.35	5.19	6.30	1.66	1.78	2.22
		min	0.87	1.09	1.77	3.22	3.29	4.09	4.94	0.97	1.36	1.60
Water flow in heating 4 pipes [l/h]	(3)	max	158	206	275	430	478	556	680	194	201	271
		med	118	151	207	355	374	447	542	146	157	196
		min	75	94	152	277	283	352	425	84	119	141
Pressure drop in heating 4 pipes [kPa]	(3)	max	4.7	9.3	15.6	23.3	21.5	36.0	46.2	6.9	9.2	16.5
		med	2.8	5.4	11.0	15.9	14.0	24.2	30.7	4.2	6.0	9.3
		min	1.2	2.4	5.6	9.8	7.7	15.4	19.5	1.0	3.7	5.3
Air flow [m ³ /h]		max	456	574	792	1082	1304	1567	1995	437	608	833
		med	298	373	489	757	904	1080	1370	284	400	486
		min	138	170	287	504	568	715	876	129	259	290
Sound power level [dB(A)]		max	55	59	60	57	62	63	69	55	53	56
		med	44	48	47	48	51	53	59	42	42	44
		min	29	29	33	37	39	43	48	30	33	30
Sound pressure level [dB(A)]	(4)	max	46	50	51	48	53	54	60	46	44	46
		med	35	39	38	37	42	44	50	33	32	34
		min	21	21	24	26	30	34	39	20	24	20
Power supply [V-ph-Hz]		230 / 1 / 50 + E										
Power input [W]	max	31	54	42	46	76	89	168	35	60	38	
Dimensions	Height mm	623	623	623	699	699	699	699	395	395	395	
	Width mm	773	898	1023	1273	1273	1523	1773	680	805	930	
	Depth mm	224	224	224	254	254	254	254	230	230	230	

(1) Room temperature 27°C d.b., 19°C w.b. - Water temperature 7/12 °C

(2) Room temperature 20°C - Water inlet temperature: 45/40°C

(3) Room temperature 20°C - Water inlet temperature: 65/55°C.

(4) Sound pressure level in a 100 m³ room, at 1.5 m distance and riverberating time of 0.3 s.

(*) 512 - 514 (3v-6v-9v) | 516 (2v-5v-10v) | 520 - 522 - 524 - 528 (3v-6v-10v)



Manufacturer reserves the rights to change specifications without prior notice.

LASER ECM and LOW BODY ECM Inverter Fan Coil Units

Compatibility tables



Compatibility Options / Accessories / Models

Code		Designation		STANDARD								LOW BODY-ECM	
				LASER-ECM				CONCEALED-ECM				YLVR	YLIVR
		YLV	YLH	YLV-AF	YLH-AF	YLIV	YLIV	YLIV-AF	YLIV-AF	YLVR	YLIVR		
Coils and heaters**													
BA1**	Additional 1 row heating	•	•	•	•	•	•	•	•	•	•		
KREL**	Kit electrical heater with safety thermostat and relay	•	•	•	•	•	•	•	•				
Factory fitted thermostat (built in)													
EDCL	Microprocessor control for ECM units	•		•		•		•		•	•		
OBV11-ODC711	Omnibus control for ECM units + Analogue Plus console	•		•		•		•		•	•		
OBV11-ODC211	Omnibus control for ECM units + Display console	•		•		•		•		•	•		
Remote controllers and thermostats (wall mounted)													
EDCR	Microprocessor control for ECM units, for wall installation	•	•	•	•	•	•	•	•	•	•		
OBV10+ODC716	Omnibus control for ECM units + Remote Analogue Plus console	•	•	•	•	•	•	•	•	•	•		
OBV10+ODC216	Omnibus control for ECM units + Remote Display console	•	•	•	•	•	•	•	•	•	•		
Valves / Condensate pump / Water sensor / Minimum temperature thermostat (Factory fitted)													
J3A2 (2p)	3-way 4-ports on/off valves for 2-pipe systems	•	•	•	•	•	•	•	•	•	•		
J3A2 (4p)	3-way 4-ports on/off valves for 4-pipe systems	•	•	•	•	•	•	•	•	•	•		
J3AM (2p)	3-way 4-ports modulating valves for 2-pipe systems	•	•	•	•	•	•	•	•	•	•		
J3AM (4p)	3-way 4-ports modulating valves for 4-pipe systems	•	•	•	•	•	•	•	•	•	•		
DT (2p)	Shut-off valves for 2-pipe systems (in addition to J3A2/J3AM valves)	•	•	•	•	•	•	•	•	•	•		
DT (4p)	Shut-off valves for 4-pipe systems (in addition to J3A2/J3AM valves)	•	•	•	•	•	•	•	•	•	•		
PC	Condensate pump	•	•	•	•	•	•	•	•	•	•		
WS	Water sensor	Compatible with all the above listed controllers											
Feet and panels													
CP1	Set of painted feet	•				•							
ZL1	Set of feet + frontal socle	•											
PPV1	Vertical painted back panel	•		•						•			
PPH1	Horizontal painted back panel		•		•								
External air intake													
PA	Air intake plenum							•					
PAS	Air intake plenum collars							•					
PA90	90° air intake plenum							•					
RCA	Air intake duct fitting							•					
PM	Air delivery plenum with collars					•	•	•	•		•		
PM90	90° air delivery plenum					•	•	•	•		•		

• Compatible

Compatible with conditions

Not compatible

** Maximum of rows is indicated in the documentation, the maximum number of rows includes the heating row or electrical heater.

YHPL/YHPL-ECM High Static Pressure Blower

YHPL / YHPL-ECM 130-740 · 2 and 4 pipe system

A complete range from 1.4 kW to 8.6 kW



ECM Inverter version
also available!

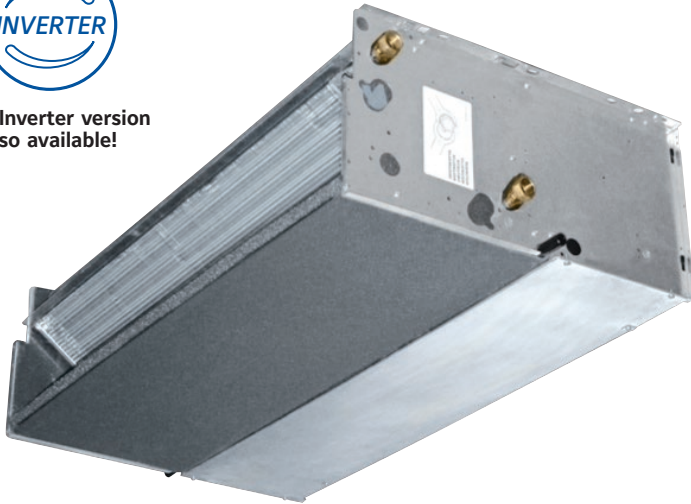

YHPL and YHPL-ECM offers a complete range able to satisfy all air conditioning need in working environments such as offices, shops, restaurants and hotel rooms, for ducted installations up to 80 Pa External Static Pressure.

These new ranges replace our earlier YHP-O series, offering lower noise levels, a strengthened structure and wider operating envelope.

The YHPL series comes in 7 sizes from 315 to 1425 m³/h with option of 3 or 4 row cooling coils, offering up to 8.6 kW of cooling, with facility to add 1 or 2 row heating coil and offer a 4 pipe system.

ECM version comes in 4 sizes and covers the airflow capacity of 360 to 1410 m³/h and up to 8.5 kW of cooling.

Wired controls



WM-3V

Remote three speeds controller

JWC-T

WC-3V + Electronic thermostat and Summer/Winter switch

JWC-AU

Automatic JWC-T



T9000 Series

• Red Dot Product Design Award Winner 2020

- Touch Screen Display
- 2 or 4 pipes FCU
- 3-speed motors or ECM motors
- 2-wiring/3-wiring on/off valves or proportional valves
- Relay designed for 100,000 switching cycles
- Modbus or BACnet protocols



T7600 Series

- LCD Screen Display
- 2 or 4 pipes FCU
- On/off or proportional
- 3-speed motors or ECM motors
- Modbus RTU



TUC03+ Terminal unit controller

BacNET and N2 Metasys network compatible



Features

- 7 sizes
- From 1.4 to 8.6 kW cooling
- Horizontal or vertical version
- Low noise operation
- 5 speed fan
- A wide range of thermostats and accessories
- Available with left or right connections

Optionally the main valve, auxiliary valve (4 tubes), controller and wiring can be assembled from factory, for an easy installation in a centralized management system.



Selection software

YHPL High Static Pressure Blower

1.4 kW to 8.6 kW



Technical features

YHPL model (2 pipes)		130	140	230	240	330	340	430	440	530	540	630	640	730	740
Total cooling capacity [kW] (1)	max	2	2.22	3.6	4.28	4.72	5.36	5.47	5.94	5.72	6.22	7.11	7.82	7.7	8.62
	med	1.88	2.07	3.4	4.01	4.42	4.99	4.97	5.36	5.04	5.44	6.62	7.25	7.11	7.92
	min	1.43	1.54	2.57	2.93	2.68	2.89	3.85	4.1	3.3	3.48	3.99	4.23	5.58	6.1
Sensible cooling capacity [kW] (1)	max	1.44	1.57	2.7	3.04	3.55	3.84	4.22	4.46	4.19	4.52	5.36	5.72	5.89	6.38
	med	1.35	1.46	2.53	2.84	3.3	3.55	3.77	3.97	3.64	3.89	4.94	5.26	5.37	5.8
	min	1.01	1.07	1.85	2.03	1.9	2.0	2.82	2.95	2.31	2.43	2.83	2.96	4.06	4.34
Pressure drop in cooling [kPa] (1)	max	20.00	11.00	19.60	31.30	17.70	36.10	23.20	15.60	33.10	18.10	18.70	15.60	21.70	18.70
	med	17.00	9.70	17.70	27.90	15.70	31.70	19.40	12.90	26.30	14.20	16.40	13.60	18.80	16.10
	min	11.00	5.60	10.60	15.80	6.30	11.80	12.20	7.90	12.20	6.30	6.60	5.10	12.20	10.10
Heating capacity [kW] (2)	max	2.11	2.23	3.98	4.34	5.22	5.42	6.27	6.55	6.25	6.54	7.58	8.34	8.49	9.42
	med	1.96	2.07	3.7	4.02	4.82	4.99	5.56	5.77	5.36	5.57	6.96	7.63	7.73	8.52
	min	1.43	1.49	2.67	2.85	2.71	2.76	4.1	4.22	3.33	3.41	3.94	4.17	5.82	6.3
Pressure drop in heating [kPa] (2)	max	18.00	10.50	18.30	26.20	16.60	28.90	23.00	14.50	30.40	16.70	16.50	15.00	20.20	18.60
	med	16.00	9.20	16.10	22.80	14.30	24.90	18.60	11.50	23.00	12.50	14.20	12.70	17.10	15.60
	min	9.00	5.10	8.90	12.30	5.10	8.60	10.70	6.60	9.70	5.20	5.10	4.30	10.30	9.00
Air flow [m³/h]	max	315	315	625	625	790	790	980	980	970	970	1240	1240	1425	1425
	med	290	290	575	575	720	720	850	850	810	810	1120	1120	1270	1270
	min	205	205	395	395	380	380	600	600	475	475	580	580	905	905
Available static pressure [Pa]	max	58	58	58	58	60	60	65	65	70	70	60	60	63	63
	med	50	50	50	50	50	50	50	50	50	50	50	50	50	50
	min	25	25	26	26	14	14	23	23	18	18	15	15	26	26
Fan [W]	max	51	51	94	94	110	110	148	148	140	140	145	145	186	186
	med	45	45	87	87	96	96	122	122	110	110	125	125	177	177
	min	27	27	59	59	50	50	88	88	65	65	69	69	155	155
Sound power outlet [dB(A)]	max	43	43	49	49	51	51	55	55	53	53	52	52	56	56
	med	42	42	47	47	48	48	52	52	48	48	50	50	53	53
	min	34	34	38	38	36	36	44	44	37	37	38	38	46	46
Sound pressure outlet [dB(A)] (4)	max	34	34	40	40	42	42	46	46	44	44	43	43	47	47
	med	33	33	38	38	39	39	43	43	39	39	41	41	44	44
	min	25	25	29	29	27	27	35	35	28	28	29	29	37	37
Power supply [V-ph-Hz]		230 / 1 / 50 + E													
Power input [W]	max	60	60	115	115	132	132	185	185	185	185	175	175	260	260
Absorbed current [A]	max	0.30	0.30	0.50	0.50	0.60	0.60	0.90	0.90	0.90	0.90	0.80	0.80	1.20	1.20
Dimensions	Height mm	248	248	248	248	248	248	248	248	248	248	248	248	248	248
	Width mm	689	689	904	904	1119	1119	1119	1119	1334	1134	1549	1549	1549	1549
	Depth mm	511	511	511	511	511	511	511	511	511	511	511	511	511	511

YHPL model (4 pipes)		130+1	140+1	230+1	240+1	330+1	340+1	430+1	440+1	530+1	540+1	630+1	640+1	730+1	740+1
Total cooling capacity [kW] (1)	max	2	2.22	3.6	4.28	4.72	5.36	5.47	5.94	5.78	6.22	7.11	7.82	7.7	8.62
	med	1.88	2.07	3.4	4.01	4.42	4.99	4.97	5.36	5.1	5.44	6.62	7.25	7.11	7.92
	min	1.43	1.54	2.57	2.93	2.68	2.89	3.85	4.1	3.32	3.48	3.99	4.23	5.58	6.1
Sensible cooling capacity [kW] (1)	max	1.44	1.57	2.7	3.04	3.55	3.84	4.22	4.46	4.23	4.52	5.36	5.72	5.89	6.38
	med	1.35	1.46	2.53	2.84	3.3	3.55	3.77	3.97	3.67	3.89	4.94	5.26	5.37	5.8
	min	1.01	1.07	1.85	2.03	1.9	2	2.82	2.95	2.33	2.43	2.83	2.96	4.06	4.34
Pressure drop in cooling [kPa] (1)	max	19.5	11	19.6	31.3	17.7	36.1	23.2	15.6	33.7	18.1	18.7	15.6	21.7	18.7
	med	17.4	9.7	17.7	27.9	15.7	31.7	19.4	12.9	26.7	14.2	16.4	13.6	18.8	16.1
	min	10.5	5.6	10.6	15.8	6.3	11.8	12.2	7.9	12.3	6.3	6.6	5.1	12.2	10.1
Heating capacity [kW] (3)	max	1.76	1.76	3.02	3.02	3.91	3.91	4.49	4.49	4.63	4.63	5.8	5.8	6.35	6.35
	med	1.66	1.66	2.85	2.85	3.68	3.68	4.1	4.1	4.11	4.11	5.44	5.44	5.9	5.9
	min	1.3	1.3	2.22	2.22	2.38	2.38	3.26	3.26	2.85	2.85	3.48	3.48	4.72	4.72
Pressure drop in heating [kPa] (3)	max	7.5	7.5	4.8	4.8	7.5	7.5	9.6	9.6	9.1	9.1	15.3	15.3	18.1	18.1
	med	6.8	6.8	4.3	4.3	6.7	6.7	8.2	8.2	7.4	7.4	13.7	13.7	15.8	15.8
	min	4.4	4.4	2.8	2.8	3.1	3.1	5.4	5.4	3.8	3.8	6.1	6.1	10.6	10.6
Air flow [m³/h]	max	315	315	625	625	790	790	980	980	970	970	1240	1240	1425	1425
	med	290	290	575	575	720	720	850	850	810	810	1120	1120	1270	1270
	min	205	205	395	395	380	380	600	600	475	475	580	580	905	905

Referred data at maximum speed fan and 50 Pa available static pressure.

(1) Room temperature 27°C d.b., 19°C w.b. - Water temperature 7/12 °C.

(2) Room temperature 20°C - Water temperature 45/40 °C.

(3) Room temperature 20°C - Water temperature 65/55 °C.

(4) The sound pressure levels are 9 dB(A) lower than the sound power levels and apply to the reverberant field of a 100 m³ room and a reverberation time of 0.5 sec.



Manufacturer reserves the rights to change specifications without prior notice.

YHPL-ECM Inverter High Static Pressure Blower

1.6 kW to 8.5 kW

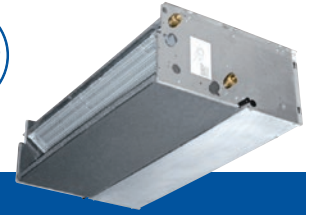

ECM the Energy Saving Technology

Brushless motor with inverter managed by dedicated controls. It permits to maintain extremely low electrical absorption and a continuous modulation of the air flow.

Technical features

YHPL-ECM model (2 pipes)		130	140	230	240	430	440	730	740
Total cooling capacity [kW]	(1) max 10v	2.23	2.48	3.55	4.25	5.43	5.91	7.67	8.47
	med 5v	1.97	2.17	3.21	3.79	4.94	5.34	6.81	7.46
	min 1v	1.64	1.77	2.72	3.14	3.84	4.09	5.66	6.12
Sensible cooling capacity [kW]	(1) max	1.63	1.78	2.68	3.04	4.21	4.45	5.86	6.33
	med	1.42	1.54	2.38	2.68	3.77	3.97	5.11	5.48
	min	1.17	1.25	1.99	2.20	2.83	2.95	4.15	4.40
Pressure drop in cooling [kPa]	(1) max	23	13	19	31	23	15	21	18
	med	19	10	16	25	19	13	17	14
	min	13	7	12	18	12	8	12	10
Heating capacity [kW]	(2) max	2.37	2.52	4.00	4.37	6.27	6.55	8.24	9.35
	med	2.05	2.17	3.51	3.80	5.56	5.77	7.09	7.96
	min	1.65	1.73	2.88	3.08	4.07	4.19	5.69	6.26
Pressure drop in heating [kPa]	(2) max	22	13	18	27	23	14	19	18
	med	17	10	15	21	19	12	15	14
	min	12	7	10	14	11	6	10	9
Air flow [m³/h]	max	360	360	630	630	980	980	1410	1410
	med	305	305	540	540	850	850	1175	1175
	min	240	240	430	430	595	595	900	900
Available static pressure [Pa]	max	68	68	70	70	66	66	72	72
	med	50	50	50	50	50	50	50	50
	min	32	32	34	34	24	24	30	30
Fan [W]	max	39	39	64	64	98	98	155	155
	med	29	29	43	43	67	67	100	100
	min	18	18	26	26	30	30	52	52
Sound power outlet [dB(A)]	max	48	48	49	49	55	55	57	57
	med	44	44	47	47	52	52	54	54
	min	38	38	42	42	44	44	47	47
Sound pressure outlet [dB(A)]	(4) max	39	39	40	40	46	46	48	48
	med	35	35	38	38	43	43	45	45
	min	29	29	33	33	35	35	38	38
Power supply [V-ph-Hz]		230 / 1 / 50 + E							
Power input [W]	max	52	52	134	134	131	131	303	303
Absorbed current [A]	max	0.4	0.4	1.1	1.1	1.1	1.1	1.4	1.4
Dimensions	Height mm	248	248	248	248	248	248	248	248
	Width mm	689	689	904	904	1119	1119	1549	1549
	Depth mm	511	511	511	511	511	511	511	511

YHPL-ECM model (4 pipes)		130+1	140+1	230+1	240+1	430+1	440+1	730+1	740+1
Total cooling capacity [kW]	(1) max 10v	2.23	2.48	3.55	4.25	5.35	5.91	7.67	8.47
	med 5v	1.97	2.17	3.21	3.79	4.88	5.34	6.81	7.46
	min 1v	1.64	1.77	2.72	3.14	3.84	4.09	5.66	6.12
Sensible cooling capacity [kW]	(1) max	1.63	1.78	2.67	3.04	4.13	4.45	5.86	6.33
	med	1.42	1.54	2.38	2.68	3.71	3.97	5.11	5.48
	min	1.17	1.25	1.98	2.20	2.83	2.95	4.15	4.40
Pressure drop in cooling [kPa]	(1) max	23	13	19	31	22	15	21	18
	med	19	10	16	25	18	13	17	14
	min	13	7	12	18	12	8	12	10
Heating capacity [kW]	(3) max	1.92	1.92	3.03	3.03	4.22	4.22	6.31	6.31
	med	1.72	1.72	2.74	2.74	3.87	3.87	5.60	5.60
	min	1.46	1.46	2.36	2.36	3.09	3.09	4.70	4.70
Pressure drop in heating [kPa]	(3) max	9	9	5	5	9	9	18	18
	med	7	7	4	4	7	7	14	14
	min	5	5	3	3	5	5	11	11
Air flow [m³/h]	max	360	360	630	630	960	960	1410	1410
	med	305	305	540	540	835	835	1175	1175
	min	240	240	430	430	595	595	900	900

Referred data at maximum speed fan and 50 Pa available static pressure.

(1) Room temperature 27°C d.b., 19°C w.b. - Water temperature 7/12 °C.

(2) Room temperature 20°C - Water temperature 45/40 °C.

(3) Room temperature 20°C - Water temperature 65/55 °C.

(4) The sound pressure levels are 9 dB(A) lower than the sound power levels and apply to the reverberant field of a 100 m³ room and a reverberation time of 0.5 sec.



Manufacturer reserves the rights to change specifications without prior notice.

YHPL and YHPL-ECM High Static Pressure Blower

Compatibility tables



Compatibility table / Codes

Model YHPL	130-140	230-240	330-340	430-440	530-540	630-640	730-740
Model YHPL-ECM	130-140	230-240	-	430-440	-	-	730-740

Accessories (factory fitted)

Valves (220V On/Off)

3 way valve for main coil VBPM-C G1-5 220V (factory fitted)	9066561				-		
3 way valve for main coil VBPM-C G6-9 220V (factory fitted)	-			9060471			-
3 way valve for main coil VBPM-C G8S 220V (factory fitted)				-			9069208
3 way valve for additional coil VBAM-C G1-9 220V (factory fitted)				9060472			
2 way valve for additional coil V2M-C G1-5 220V (factory fitted)	9060476				-		
2 way valve V2M-C G6-9 220V (factory fitted)	-			9060477			-
2 way valve V2M-C G8S 220V (factory fitted)				-			9069209
Simplified 3-way valve kit for additional coil VSPM-C G1-5 220 V (fitted)	9066571				-		
Simplified 3-way valve kit VSPM-C G6-9 220 V (factory fitted)	-			9060484			-
Simplified 3-way valve kit VSPM-C G8-S 220 V (factory fitted)				-			9069211

Accessories (supplied loose)

Valves (220V On/Off)

3 way valve for main coil VBPS-C G1-5 220V (not fitted)	9066560				-		
3 way valve for main coil VBPS-C G6-9 220V (not fitted)	-			9060474			-
3 way valve for main coil VBPS-C G8S 220V (not fitted)				-			9069206
3 way valve for additional coil VBAS-C G1-9 220V (not fitted)				9060475			
2 way valve for additional coil V2S-C G1-5 220V (not fitted)	9060478				-		
2 way valve V2S-C G6-9 220V (not fitted)	-			9060479			-
2 way valve V2S-C G8S 220V (not fitted)				-			9069207
Simplified 3-way valve kit for additional coil VSPS-C G1-5 220 V (not fitted)	9066570				-		
Simplified 3-way valve kit VSPS-C G6-9 220 V (not fitted)	-			9060481			-
Simplified 3-way valve kit VSPS-C G8-S 220 V (not fitted)				-			9069210
Other type of valves							Contact Johnson Controls

YHPL and YHPL-ECM High Static Pressure Blower

Compatibility tables



Compatibility table / Codes

Model YHPL	130-140	230-240	330-340	430-440	530-540	630-640	730-740
Model YHPL-ECM	130-140	230-240	-	430-440	-	-	730-740

Accessories (supplied loose)

Air inlet plenum PMC	9069191	9069222	9066368	9069195	9069196		
Straight inlet flange	9069371	9038002	9060724	9069375	9079376		
Inlet flange 90°	9069381	9038001	9060714	9069385	9069386		
Intake grid 90°	9060761	9060762	9060763	9068155	9038041		
Straight outlet flange	9069391	9069232	9066378	9069395	9069396		
Outlet flange 90°	9069400	9069242	9066388	9069405	9069406		
Outlet grid	9060751	9060752	9060753	9069415	9038040		
El. resistance and relays fitted on the unit (1500 W) BEL-I G3-4/15	9066613			-			
El. resistance and relays fitted on the unit (900 W) BEL-I G3-4/09	9066603			-			
El. resistance and relays fitted on the unit (600 W) BEL-I G3-4/06	9066593			-			
El. resistance and relays fitted on the unit (2000 W) BEL-I G5-6/20	-	9066615		-			
El. resistance and relays fitted on the unit (1250 W) BEL-I G5-6/12	-	9066605		-			
El. resistance and relays fitted on the unit (750 W) BEL-I G5-6/07	-	9066595		-			
El. resistance and relays fitted on the unit (2500 W) BEL-I G7-9/25		-	9066617		-		
El. resistance and relays fitted on the unit (1500 W) BEL-I G7-9/15		-	9066607		-		
El. resistance and relays fitted on the unit (1000 W) BEL-I G7-9/10		-	9066597		-		
El. resistance and relays fitted on the unit (2750 W) BEL-I SL5/27			-	9038037		-	
El. resistance and relays fitted on the unit (1650 W) BEL-I SL5/16			-	9038038		-	
El. resistance and relays fitted on the unit (1100 W) BEL-I SL5/11			-	9038039		-	
El. resistance and relays fitted on the unit (3500 W) BEL-I SL6-7/35			-			9038047	
El. resistance and relays fitted on the unit (2500 W) BEL-I SL6-7/25			-			9038048	
El. resistance and relays fitted on the unit (1000 W) BEL-I SL6-7/10			-			9038049	
NC auxiliary condensate tray ACT-NC			6066039				
Mounted condensate pump DRCV - vertical units (auxiliary condensate tray included)			9066297				
Not mounted condensate pump DRCV - vertical units (auxiliary condensate tray included)			9066296				
Not mounted condensate pump DRPI-C - only horizontal installation (auxiliary condensate tray included)			9066180				
Condensate drain pipe SCR			6060420				
Front air intake KAF	9069361	9069072	9069073	9069365	9069366		

YHPL and YHPL-ECM High Static Pressure Blower

Compatibility tables



Compatibility table / Codes

Controls for YHPL models	130-140	230-240	330-340	430-440	530-540	630-640	730-740
Remote three speed control WM-3V (1) (4)				9066642			
Remote three speed control + electronic thermostat and manual S/W switch JWC-T (2)				9066630K			
Remote three speed control + electronic thermostat and centralized/manual S/W switch JWC-TQR (2) (3)				9066631K			
Automatic speed control with electronic thermostat and S/W switch - JWC-AU (to be used with UPM-AU and UP-AU only) (2) (3)				9066632K			
Automatic remote control with electronic thermostat, S/W switch and liquid crystal display T-MB (2) (3)				9066331E			
Automatic speed control with electronic thermostat to be mounted in the light wall box WM-503-AC-EC (to be used with UP-503-AC-EC only)				9066686			
Electromechanical thermostat T2T (4) (5)				9060174			
Power unit UPM-AU for JWC-AU and T-MB remote controls, fitted on the unit				9066641			
Power unit UP-AU for JWC-AU and T-MB remote controls, not fitted on the unit				9066640			
Power unit UP-503-AC-EC for WM-503-AC-EC remote control only, not fitted on the unit				9066687			
Control accessories for all versions (supplied with separate packaging)							
Low temperature cut-out for controls WM-3V and JWC-T				9053048			
Low temperature cut-out for controls JWC-TQR, WM-503-AC-EC and UP-AU power unit				3021090			
T2 sensor to be used as Change-over for UP-AU power unit				9025310			
Change-over 15-25 for control JWC-TQR				9053049			
Receiver board for control JWC-T and JWC-TQR				9066311			
Controls for YHPL-ECM models	130-140	230-240	-	430-440	-	-	730-740
Automatic speed control with electronic thermostat and S/W switch - JWC-AU (to be used with UPM-AU and UP-AU only) (2) (3)				9066632K			
Automatic remote control with electronic thermostat, S/W switch and liquid crystal display T-MB (to be used with UPM-AU and UP-AU only) (2) (3)				9066331E			
WM-S-ECM Continuous fan speed control with electronic thermostat, summer/winter switch and LCD display				9066644			
Power unit UPM-AU for JWC-AU and T-MB remote controls, fitted on the unit				9066641			
Power unit UP-AU for JWC-AU and T-MB remote controls, not fitted on the unit				9066640			

(1) Not to be used with valves. (2) Can be used with valves and/or low temperature cut-out.

(3) Can be used with Change Over. (4) Not suitable with -E electric heater. (5) Can be used with valve and not to be used with low temperature cut-out.

RFHP-O/RFHPO-ECM High static pressure blower with centrifugal fan

RFHP-O/RFHPO-ECM 14 - 74+2 · 2 & 4 pipe system

A complete range from 4.1 kW to 30.6 kW



ECM Inverter version also available!

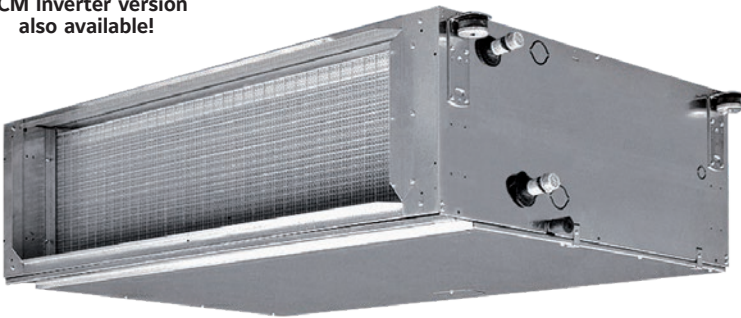

RFHP-O and RFHPO-ECM ranges are designed and built for concealed installations. With small dimensions, they are very silent and offers elevated air flow rates and up to 250 Pa External Static Pressure.

They are suitable for climate control for small and medium commercial and sports environments or for large civil environments and integrate perfectly in regular false ceilings.

The RFHP-O range is available with the combination of either 3 or 4 row coils (sizes 1÷5) with the possibility to add a 1 or 2 row coil (3+1, 4+1, 3+2, 4+2 versions for 4 pipe systems), and 4 or 6 row coils (sizes 6-7) with the possibility to add a 2 row coil (4+2, 6+2 versions for 4 pipe systems).

ECM version comes in 5 sizes and its ability to continuously vary the air flow gives great regulation and control flexibility, at the same time ensuring excellent environmental conditions and extremely low electrical consumption.

Wired controls



WM-3V

Remote three speeds controller

JWC-T

WC-3V + Electronic thermostat and Summer/Winter switch

JWC-AU

Automatic JWC-T



T9000 Series

• Red Dot Product Design Award Winner 2020

- Touch Screen Display
- 2 or 4 pipes FCU
- 3-speed motors or ECM motors
- 2-wiring/3-wiring on/off valves or proportional valves
- Relay designed for 100,000 switching cycles
- Modbus or BACnet protocols



T7600 Series

- LCD Screen Display
- 2 or 4 pipes FCU
- On/off or proportional
- 3-speed motors or ECM motors
- Modbus RTU



TUC03+ Terminal unit controller

BacNET and N2 Metasys network compatible



Features

- 7 sizes
- From 4.0 to 30.63 kW cooling
- Concealed version
- Low noise operation
- 5 speed fan
- A wide range of thermostats and accessories
- Available with left or right connections

Optionally the main valve, auxiliary valve (4 tubes), controller and wiring can be assembled from factory, for an easy installation in a centralized management system.



Selection software

RFHP-O High static pressure blower

4.1 kW to 30.6 kW



Technical features

RFHP-O model 2 pipes (4 row coil)		14	24	34	44	54 (*)	64 (*)	74 (*)	
Total cooling capacity [kW]	(1)	max	5.92	8.15	10.71	13.60	17.76	22.89	30.63
		med	5.21	7.01	9.76	12.40	16.19	18.73	25.33
		min	4.17	4.99	8.71	10.90	14.54	12.42	21.54
Sensible cooling capacity [kW]	(1)	max	5.03	6.62	8.65	10.90	14.37	17.98	24.53
		med	4.26	5.48	7.68	9.70	12.80	14.16	19.46
		min	3.25	3.66	6.67	8.25	11.21	8.88	16.05
Pressure drop in cooling [kPa]	(1)	max	9.6	16.8	23.4	20.9	19.4	22.6	27.6
		med	7.6	12.7	19.8	17.7	16.3	15.3	19.3
		min	5.1	6.9	16.0	13.9	13.3	7.4	14.4
Heating capacity [kW]	(2)	max	7.67	10.10	13.19	16.53	22.93	43.60	61.14
		med	6.44	8.27	11.75	14.92	20.32	33.52	47.85
		min	4.98	5.57	10.20	12.79	17.67	20.86	39.34
Pressure drop in heating [kPa]	(2)	max	11.3	18.3	24.8	21.3	22.8	14.7	18.8
		med	8.2	17.0	23.0	17.7	18.3	9.1	12.1
		min	5.2	6.2	15.6	13.4	14.2	3.9	8.5
Air flow [m³/h]		max	1410	1825	2440	3020	3850	4800	7100
		med	1125	1410	2075	2580	3280	3385	5070
		min	790	840	1710	2070	2740	1880	3925
Fan [W]		max	191	285	470	570	760	1304	2460
		med	154	230	420	490	617	778	1758
		min	115	170	350	390	500	574	1518
Available pressure [Pa]		max	58	61	65	66	70	77	81
		med	52	56	62	63	67	71	75
		min	44	44	57	59	63	63	71
Sound power outlet [dB(A)]		max	49	52	56	57	61	68	72
		med	43	47	53	54	58	62	66
		min	35	35	48	50	54	54	62
Sound pressure outlet [dB(A)]	(4)	max	75	80	70	70	70	150	150
		med	50	50	50	50	50	150	150
		min	25	15	30	35	35	150	150
Power supply [V-ph-Hz]		230 / 1 / 50 + E							
Dimensions	Height mm	310	310	360	360	435	488	588	
	Width mm	1133	1133	1133	1445	1445	1535	1535	
	Depth mm	698	698	698	853	853	1100	1100	
RFHP-O model 4 pipes (with additional coil)		14+1	24+1	34+1	44+1	54+1 (*)	64+2 (*)	74+2 (*)	
Total cooling capacity [kW]	(1)	max	5.79	8.03	10.58	13.46	16.73	22.52	30.36
		med	5.11	6.95	9.67	12.34	15.31	18.56	25.25
		min	4.09	4.99	8.61	10.85	13.75	12.33	21.53
Sensible cooling capacity [kW]	(1)	max	4.87	6.49	8.51	10.72	13.56	17.62	24.28
		med	4.16	5.42	7.60	9.61	12.13	14.02	19.39
		min	3.18	3.66	6.58	8.21	10.62	8.81	16.05
Pressure drop in cooling [kPa]	(1)	max	9.20	16.30	22.90	20.50	17.40	22.00	27.10
		med	7.30	12.50	19.40	17.40	14.70	15.00	19.10
		min	4.90	6.90	15.70	13.80	12.00	7.30	14.40
Heating capacity [kW]	(3)	max	5.47	7.16	9.20	12.00	15.28	37.13	51.31
		med	4.87	6.28	8.47	11.07	14.00	29.78	41.88
		min	3.96	4.63	7.62	9.83	12.67	19.81	35.50
Pressure drop in heating [kPa]	(3)	max	21.0	31.9	22.3	39.5	36.3	37.0	46.1
		med	17.0	25.2	19.3	34.1	31.1	24.9	32.0
		min	11.7	14.5	15.9	27.6	26.0	11.9	23.8
Air flow [m³/h]		max	1350	1775	2390	2960	3800	4680	6980
		med	1090	1390	2045	2545	3245	3330	5040
		min	770	840	1680	2055	2700	1860	3920
Fan [W]		max	191	285	470	570	760	1327	2376
		med	154	230	420	490	617	750	1727
		min	115	170	350	390	500	565	1499

(1) Room temperature 27°C d.b., 19°C w.b. - Water temperature 7/12 °C.

(2) Room temperature 20°C - Water temperature 45/40 °C.

(3) Room temperature 20°C - Water temperature 65/55 °C.

(4) The sound pressure levels are 9 dB(A) lower than the sound power levels and apply to the reverberant field of a 100 m³ room and a reverberation time of 0.5 sec.

* Models not covered by EUROVENT certification program.



Manufacturer reserves the rights to change specifications without prior notice.

RFHPO-ECM Inverter high static pressure blower

4.0 kW to 18.2 kW



ECM the Energy Saving Technology

Brushless motor with inverter managed by dedicated controls. It permits to maintain extremely low electrical absorption and a continuous modulation of the air flow.

Technical features

RFHPO-ECM model 2 pipes (4 row coil)		14	24	34	44	54 (*)	
Total cooling capacity [kW]	(1)	max	5.61	7.94	10.81	13.99	18.17
		med	5.11	6.86	9.70	12.39	16.70
		min	4.14	5.44	7.87	10.47	13.73
Sensible cooling capacity [kW]	(1)	max	4.72	6.44	8.72	11.23	14.75
		med	4.18	5.36	7.61	9.65	13.26
		min	3.24	4.08	5.93	7.90	10.46
Pressure drop in cooling [kPa]	(1)	max	8.7	15.8	21.6	21.7	21.4
		med	7.2	11.8	17.4	16.9	17.9
		min	4.9	7.7	11.7	12.2	12.3
Heating capacity [kW]	(2)	max	7.76	10.62	13.06	18.08	23.25
		med	6.80	8.64	11.25	15.15	20.51
		min	5.18	6.42	8.64	12.13	15.90
Pressure drop in heating [kPa]	(2)	max	11.1	18.8	21.4	23.9	25.4
		med	8.7	12.9	16.4	17.4	20.3
		min	5.3	7.5	10.1	11.6	12.8
Air flow [m³/h]		max	1310	1780	2390	3080	3920
		med	1100	1360	1950	2440	3320
		min	780	940	1380	1840	2400
Fan [W]		max	144	225	340	530	702
		med	88	110	195	253	383
		min	40	44	80	110	166
Sound power outlet [dB(A)]		max	59	61	64	67	71
		med	52	55	60	62	67
		min	45	45	52	55	58
Sound pressure outlet [dB(A)]	(4)	max	50	52	55	58	62
		med	43	46	51	53	58
		min	36	36	43	46	49
Available pressure [Pa]		max	72	85	75	80	68
		med	50	50	50	50	50
		min	26	24	25	28	26
Power supply [V-ph-Hz]		230 / 1 / 50 + E					
Dimensions	Height mm	310	310	360	360	435	
	Width mm	1133	1133	1133	1445	1445	
	Depth mm	698	698	698	853	853	

RFHPO-ECM model 4 pipes (with additional coil)		14+1	24+1	34+1	44+1	54+1 (*)	
Total cooling capacity [kW]	(1)	max	5.46	7.87	10.70	13.90	18.00
		med	4.94	6.79	9.59	12.27	16.62
		min	4.04	5.36	7.76	10.36	13.66
Sensible cooling capacity [kW]	(1)	max	4.55	6.35	8.61	11.13	14.58
		med	4.01	5.30	7.51	9.53	13.19
		min	3.14	4.01	5.83	7.79	10.39
Pressure drop in cooling [kPa]	(1)	max	8.3	15.5	21.2	21.4	19.4
		med	6.8	11.6	17.1	16.6	16.3
		min	4.6	7.5	11.4	12.0	11.2
Heating capacity [kW]	(3)	max	4.62	6.25	8.02	10.75	13.77
		med	4.18	5.42	7.20	9.48	12.67
		min	3.43	4.33	5.90	8.06	10.53
Pressure drop in heating [kPa]	(3)	max	16.0	26.4	17.3	33.0	29.9
		med	13.4	20.4	14.3	26.3	25.7
		min	9.4	13.6	9.9	19.6	18.5
Air flow [m³/h]		max	1250	1750	2350	3040	3860
		med	1040	1340	1920	2400	3300
		min	750	920	1350	1810	2380
Fan [W]		max	144	225	340	530	695
		med	88	115	200	253	384
		min	40	44	80	110	168

(1) Room temperature 27°C d.b., 19°C w.b. - Water temperature 7/12 °C.

(2) Room temperature 20°C - Water temperature 45/40 °C.

(3) Room temperature 20°C - Water temperature 65/55 °C.

(4) The sound pressure levels are 9 dB(A) lower than the sound power levels and apply to the reverberant field of a 100 m³ room and a reverberation time of 0.5 sec.

* Models not covered by EUROVENT certification program.



Manufacturer reserves the rights to change specifications without prior notice.

RFHP-O and RFHPO-ECM

High static pressure blower with centrifugal fan

Compatibility tables



Compatibility table / Codes

Controls for RFHP-O models	14	24	34	44	54	64	74
Remote three speed control WM-3V (1) (4)				9066642			
Remote three speed control + electronic thermostat and manual S/W switch JWC-T (2)				9066630K			
Remote three speed control + electronic thermostat and centralized/manual S/W switch JWC-TQR (2) (3)				9066631K			
Automatic speed control with electronic thermostat and S/W switch - JWC-AU (to be used with UPM-AU and UP-AU only) (2) (3)				9066632K			
Automatic remote control with electronic thermostat, S/W switch and liquid crystal display T-MB (2) (3)				9066331E			
Receiving board for centralized control SEL-S				9079109			
Power unit UPOM1-AU for JWC-AU and T-MB remote controls, fitted on the unit	9034170				-		
Power unit UPOM3-AU for JWC-AU and T-MB remote controls, fitted on the unit	-				9034180		
Power unit UPO1-AU for JWC-AU and T-MB remote controls, not fitted on the unit	9034169				-		
Power unit UPO3-AU for JWC-AU and T-MB remote controls, not fitted on the unit	-				9034179		
Electronic controls for MB boards							
Mounted power unit MB-M (T-MB wall control included)				9066332			
Not mounted power unit MB-S (T-MB wall control included)				9066333			
Multifunction wall control up to 60 units PSM-DI				3021293			
Change-over 15-25 for control JWC-TQR				9053049			
Receiver board for control JWC-T and JWC-TQR				9066311			
Management system for a network of fan coils with MB electronic board							
Hardware/software supervisory system (to be used with MB board only) NET				9079118			
Router-S for NET (default) or for BMS systems no provided by YORK				3021290			
Relay output board SIOS				3021292			
Controls for RFHPO-ECM models							
Automatic speed control with electronic thermostat and S/W switch - JWC-AU (to be used with UPM-AU and UP-AU only) (2) (3)				9066632K			
Automatic remote control with electronic thermostat, S/W switch and liquid crystal display T-MB (to be used with UPM-AU and UP-AU only) (2) (3)				9066331E			
Power unit UPOM1-AU for JWC-AU and T-MB remote controls, fitted on the unit				9034170			
Power unit UPO1-AU for JWC-AU and T-MB remote controls, not fitted on the unit				9034169			
Electronic controls for MB boards							
Mounted power unit MB-M (T-MB wall control included)				9066332			
Not mounted power unit MB-S (T-MB wall control included)				9066333			
Multifunction wall control up to 60 units PSM-DI				3021293			
Change-over 15-25 for control JWC-TQR				9053049			
Receiver board for control JWC-T and JWC-TQR				9066311			
Management system for a network of fan coils with MB electronic board							
Hardware/software supervisory system (to be used with MB board only) NET				9079118			
Router-S for NET (default) or for BMS systems no provided by YORK				3021290			
Relay output board SIOS				3021292			

(1) Not to be used with valves. (2) Can be used with valves and/or low temperature cut-out.
 (3) Can be used with Change Over. (4) Not suitable with -E electric heater. (5) Can be used with valve and not to be used with low temperature cut-out.

Model RFHP-O	14	24	34	44	54	64	74
Model RFHPO-ECM	14	24	34	44	54	-	-
Accessories (supplied loose)							
Main coil valve kit (220V On/Off)	9034255	9034256		9034257		9034259	
Auxiliary coil valve kit (220V On/Off)				-		9034258	
Main coil 3 way valve kit 24V actuator	9034250	9034251		9034252		9034270	9034272
Auxiliary coil 3 way valve kit 24V actuator		9034253		9034254		9034271	9034273
External auxiliary condensate collection tray				9034029			
Electric heater 230V	9034201	9034210			-		
Electric heater 400V	9034202	9034211	9034222	9034232	9034242	9034204	9034205
Intake/supply spigot plenum	9034200		9034220	9034230	9034240	9034280	9034290
ePM10 50% - G4 class synthetic filter	6034050		6034052	6034053	6034054	6034056	6034057
ePM10 70% - F6 class Synthetic Filter			-			6034197	6034198
Antivibrating connection	6034200		6034201	6034202	6034203	6034204	6034205

YEFB High static pressure blower

2 and 4 pipe system

A complete range from 4.3 kW up to 27.5 kW



CSR00 (Wall mounted)
Fan speed selector



CMR00 (Wall mounted)
Thermostat with manual fan speed and S/W change over



CER00 (Wall mounted)
Thermostat with manual fan speed and automatic change over

CER20 (Wall mounted)
Thermostat with auto. fan speed and automatic change over

CER30 (Wall mounted)
Thermostat with auto. fan speed and automatic change over for modulating valve



TUC03+ Terminal unit controller
BacNET and N2 Metasys network compatible



YEFB Blower units are available in 6 sizes for horizontal concealed installations: thanks to their high ESP fans that can handle up to 250Pa, they are the ideal solution for air conditioning large spaces.



Selection software

Features

- 6 unit sizes for horizontal mounting
- Handles high external static pressure up to 250Pa
- Choice of 2 or 4 pipe systems
- Twin centrifugal fans
- Horizontal air return
- Air distribution plenum
- Electric heater option
- Optional paint finish
- F5 grade filter option
- 5 Row cooling coil option on sizes 060, 070
- EUROVENT Certified

YEFB High static pressure blower

4.3 kW to 27.5 kW



Unit performance at different Pa external static pressure, with 4 row cooling coil

Model YEFB		020-4	030-4	040-4	050-4	060-4*	070-4*
Total cooling capacity [kW]	(1) max	6.95	9.49	11.77	13.72	23.83	27.52
	med	5.90	8.23	10.35	12.6	21.59	25.55
	min	4.30	7.11	8.91	11.36	17.15	23.56
Sensible cooling capacity [kW]	(1) max	4.99	7.91	9.94	11.80	18.89	22.00
	med	4.14	6.7	8.61	10.60	16.84	20.27
	min	2.98	5.68	7.17	9.44	12.93	18.54
Water flow in cooling [l/h]	(1) max	1195	1632	2024	2360	4099	4699
	med	1015	1416	1780	2167	3714	4361
	min	740	1223	1533	1954	2950	4018
Pressure drop in cooling [kPa]	(1) max	17.4	31.5	30.6	40.4	28.0	37.5
	med	12.2	24.1	23.3	33.8	23.2	33.0
	min	6.5	18.4	17.9	28.3	15.1	28.7
Heating capacity 2 pipes [kW]	(2) max	7.08	11.40	14.32	17.4	28.08	33.85
	med	6.20	9.62	12.19	15.53	24.95	30.95
	min	4.55	8.20	10.4	13.85	18.9	28.09
Water flow in heating 2 pipes [l/h]	(2) max	1219	1962	2465	2727	4495	5855
	med	1067	1656	2098	2673	4034	5354
	min	783	1411	1788	2392	3047	4858
Pressure drop in heating 2 pipes [kPa]	(2) max	13.3	34.0	36.1	51.0	30.2	49.6
	med	10.3	25.7	26.9	41.3	23.5	42.4
	min	4.8	19.2	20.0	33.4	14.6	35.7
Air flow [m³/h]	max	1145	1910	2680	3250	4120	5512
	med	920	1520	2130	2870	3610	4936
	min	620	1205	1655	2470	2580	4383
Sound power level [dB(A)]	max	64.0	65.0	69.0	72.0	77.0	81.0
	med	58.0	61.0	63.0	68.0	74.0	79.0
	min	48.0	57.0	57.0	65.0	65.1	76.0
Sound pressure level [dB(A)]	(3) max	53.0	54.0	58.0	61.0	66.0	70.0
	med	47.0	50.0	52.0	57.0	63.0	68.0
	min	37.0	46.0	46.0	54.0	54.0	65.0
Power supply [V-ph-Hz]		230 / 1 / 50					
Power input [W]	max	171	352	451	588	1007	1 781
Absorbed current [A]	max	0.74	1.62	2.05	2.83	4.47	7.90
Dimensions	Height mm	407.6	407.6	407.6	407.6	517.6	517.6
	Width mm	902	902	902	902	1 160	1 160
	Depth mm	989.6	989.6	1 239.6	1 239.6	1 634.6	1 634.6

(1) Room temperature 27°C d.b., 19°C w.b. - Water temperature 7/12 °C

(2) Room temperature 20°C - Water inlet temperature: 45/40°C

(3) Lp= Total sound pressure level in open field at 1 m from the source

For each unit size there are 2, 3 and 4 row coils available; for 4 pipe systems it is possible to install a 2 or 3 row coil. It is therefore possible to have a combination of maximum 7 rows (4 row cooling + 3 row heating). For models 060 and 070 are also 5 row coils available, which can be combined with additional 2 or 3 row coils.

* Models not covered by EUROVENT certification program.



Manufacturer reserves the rights to change specifications without prior notice.

YEFB-ECM Inverter high static pressure blower

2 and 4 pipe system

A complete range from 4.2 kW up to 23.8 kW



YEFB-ECM high pressure ducted fan coils with energy saving motors, are specifically designed for ducted installations, with external static pressure up to 300 Pa. Their high pressure fan decks permit to satisfy every request of heating and cooling application in big environments.

The YEFB-ECM high pressure fan coil units are available in 5 sizes for concealed horizontal installation, in 2 and 4 pipe systems. For each unit size there are 2, 3 and 4 row coils available and models 060 are also 5 row coils available, which can be combined with additional 2 or 3 row coils.



Selection software



EDCR (Wall mounted)

Thermostat with manual or automatic fan speed and automatic change over for modulating valve



TUC03+ Terminal unit controller

BacNET and N2 Metasys network compatible



Features

- 5 unit sizes for horizontal mounting
- Handles high external static pressure up to 300Pa
- Choice of 2 or 4 pipe systems
- Twin centrifugal fans
- Horizontal air return
- Air distribution plenum
- Electric heater option
- Optional paint finish
- F5 grade filter option
- 5 Row cooling coil option on size 060
- EUROVENT Certified

YEFB-ECM Inverter high static pressure blower

4.2 kW to 23.8 kW



ECM the Energy Saving Technology

Brushless motor with inverter managed by dedicated controls. It permits to maintain extremely low electrical absorption and a continuous modulation of the air flow.

Unit performance at different Pa external static pressure, with 4 row cooling coil

Model YEFB		020-4	030-4	040-4	050-4	060-4*	
Total cooling capacity [kW]	(1)						
		max	6.75	9.94	13.64	14.40	23.82
		med	5.62	8.13	11.22	13.25	20.32
		min	4.23	7.11	8.43	11.90	18.79
Sensible cooling capacity [kW]	(1)						
		max	5.27	7.98	11.17	11.94	18.76
		med	4.30	6.34	10.82	10.82	15.78
		min	3.16	5.47	6.46	9.56	14.49
Water flow in cooling [l/h]	(1)						
		max	1162	1711	2348	2478	4088
		med	812	1399	1931	2281	3488
		min	728	1224	1451	2048	3224
Pressure drop in cooling [kPa]	(1)						
		max	16.5	35.4	45.0	50.9	30.8
		med	11.6	24.0	30.6	42.9	23.4
		min	6.8	18.8	17.7	34.7	20.5
Heating capacity 2 pipes [kW]	(2)						
		max	7.07	11.52	16.24	18.07	28.00
		med	5.65	9.07	12.87	16.25	23.25
		min	4.11	7.81	9.35	14.37	21.23
Water flow in heating 2 pipes [l/h]	(2)						
		max	1217	1983	2795	3110	4866
		med	972	1561	2215	2797	4041
		min	707	1344	1609	2473	3689
Pressure drop in heating 2 pipes [kPa]	(2)						
		max	15.4	39.1	53.2	65.7	32.1
		med	10.4	25.4	34.8	54	23.2
		min	5.8	19.3	19.3	43.1	19.8
Air flow [m³/h]							
		max	1040	1948	2848	3217	4521
		med	796	1471	2160	2834	3599
		min	549	1241	1484	2442	2972
Sound power level [dB(A)]							
		max	65	68	71	75	76
		med	58	61	66	72	77
		min	49	57	57	69	74
Sound pressure level [dB(A)]	(3)						
		max	54	57	60	64	70
		med	47	50	55	61	66
		min	38	46	46	58	63
Power supply [V-ph-Hz]		230 - 1 - 50/60 **					
Power input [W]	max	161	261	405	478	926	
Absorbed current [A]	max	1.08	1.12	1.85	2.17	4.16	
Dimensions	Height	mm	407.6	407.6	407.6	407.6	517.6
	Width	mm	902	902	902	902	1 160
	Depth	mm	989.6	989.6	1 239.6	1 239.6	1 634.6

(1) Room temperature 27°C d.b., 19°C w.b. - Water temperature 7/12 °C

(2) Room temperature 20°C - Water inlet temperature: 45/40°C

(3) Lp= Total sound pressure level in open field at 1 m from the source

4 pipe system not available with 4R heating coil

* Models not covered by EUROVENT certification program.

** For a correct selection at 60 Hz of the units, pls use the YORK software for selection.



Manufacturer reserves the rights to change specifications without prior notice.

YEFB Hydro Blower

YEFB-ECM Inverter Hydro Blower

Compatibility tables



Compatibility Options / Accessories / Models

Code	Designation	YEFB / YEFB-ECM					
		020	030	040	050	060	070
Coils and heaters**							
BA2	Additional 2 row heating	•	•	•	•	•	•
BA3	Additional 3 row heating	•	•	•	•	•	•
KREL	Kit electrical heater with safety thermostat and relay	•	•	•	•	•	•
Factory fitted electric box							
CBL10	Transformer 230/24V	•	•	•	•	•	•
CBL20	Parallel connection for ON/OFF valve	•	•	•	•	•	•
CBL30	Parallel connection for modulating valve	•	•	•	•	•	•
Remote controllers and thermostats (wall mounted)							
CSR00	Fan speed selector (wall mounted)	•	•	•	•	•	•
CMR00	Thermostat with manual fan speed and S/W change over	•	•	•	•	•	•
CER00	Thermostat with manual fan speed, dead band, automatic change over	Compatible with electrical heaters					
CER20	Thermostat with automatic fan speed, dead band, automatic change over	Compatible with electrical heaters					
CER30	Thermostat with automatic fan speed, dead band, automatic change over for modulating valves	•	•	•	•	•	•
EDCR	Thermostat with manual or automatic fan speed, dead band, automatic change over for modulating valves - Only for ECM models	Compatible with electrical heaters					
OxT+OC716	Omnibus control + Remote Analogue Plus	Compatible with electrical heaters					
OxT+OC216	Omnibus control + Remote Display console	Compatible with electrical heaters					
Valves (Supplied loose) / Condensate pump / Water sensor (Factory fitted)							
J3B2 (2p)	3-way 4-ports on/off valves for 2-pipe systems	•	•	•	•		
J3B2 (4p)	3-way 4-ports on/off valves for 4-pipe systems	•	•	•	•		
J3C2 (2p)	3-way 4-ports on/off valves for 2-pipe systems					•	•
J3C2 (4p)	3-way 4-ports on/off valves for 4-pipe systems					•	•
J3BM (2p)	3-way 4-ports modulating valves for 2-pipe systems	•	•	•	•		
J3BM (4p)	3-way 4-ports modulating valves for 4-pipe systems	•	•	•	•		
J3CM (2p)	3-way 4-ports modulating valves for 2-pipe systems					•	•
J3CM (4p)	3-way 4-ports modulating valves for 4-pipe systems					•	•
J2B2 (2p)	2-way on/off valves for 2-pipe systems	•	•	•	•		
J2B2 (4p)	2-way on/off valves for 4-pipe systems	•	•	•	•		
J2C2 (2p)	2-way modulating valves for 2-pipe systems					•	•
J2C2 (4p)	2-way modulating valves for 4-pipe systems					•	•
DTB (2p)	Shut-off valves for 2-pipe systems supplied loose in addition to J3B2 and J3BM valves	•	•	•	•		
DTB (4p)	Shut-off valves for 4-pipe systems (in addition to J3B2/J3BM valves)	•	•	•	•		
PC	Condensate pump	•	•	•	•	•	•
AS	Air sensor	•	•	•	•	•	•
WS	Water sensor	Compatible with CEL/CER/EDCR					
Plenums							
PAS	Air intake plenum collars	•	•	•	•	•	•
PM	Air delivery plenum with collars	•	•	•	•	•	•
PM + Grill	Air delivery plenum painted with air outlet grill	•	•	•	•	•	•

- Compatible
- ◻ Compatible with conditions
- ◻ Not compatible

Dimensions & Weights

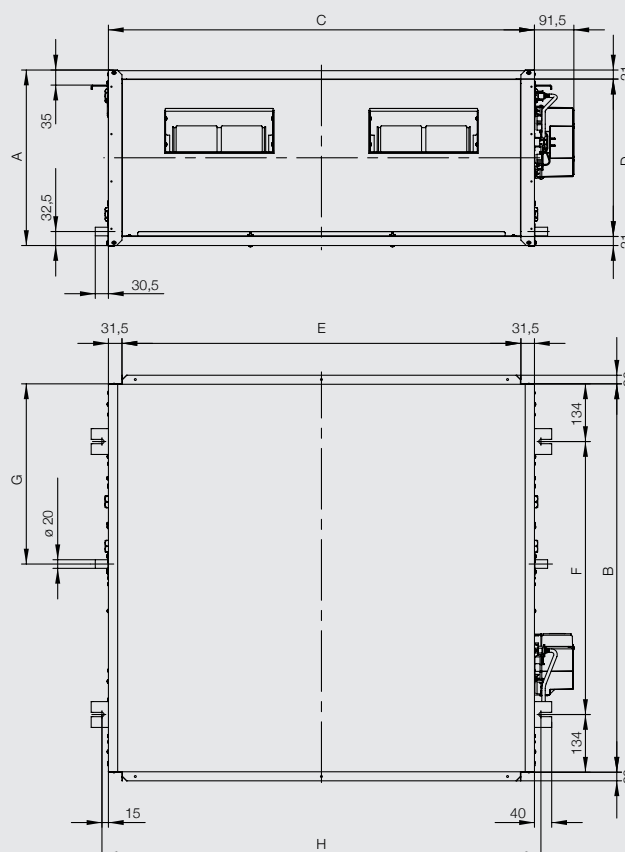

All dimensions in mm. Drawings not in scale.

Model YEFB / YEFB-ECM		020-4	030-4	040-4	050-4	060-4	070-4
A	mm	407.6	407.6	407.6	407.6	517.6	517.6
B	mm	902	902	902	902	1160	1160
C	mm	989.6	989.6	1239.6	1239.6	1634.6	1634.6
D	mm	365.6	365.6	365.6	365.6	475.6	475.6
E	mm	926.6	926.6	1176.6	1176.6	1571.6	1571.6
F	mm	634	634	634	634	892	892
G	mm	418.5	418.5	418.5	418.5	446.5	446.5
H	mm	1019.6	1019.6	1269.6	1269.6	1664.6	1664.6
Weight (3R - 3 rows)	kg	64.3	64.3	79.3	79.3	126.0	126.0

Model YEFB		(2-3-4 rows)	(2-3-4 rows)	(2-3-4 rows)	(2-3-4 rows)	(2-3-4-5 rows)	(2-3-4-5 rows)
Weight of the coil	kg	4.8 - 5.8 - 7.6	4.8 - 5.8 - 7.6	5.6 - 7.4 - 9.6	5.6 - 7.4 - 9.6	9.4 - 12.8 - 17.4 - 21.5	9.4 - 12.8 - 17.4 - 21.5
Water connection		G1/2" F	G1/2" F	G1/2" F	G1/2" F	G1" M	G1" M
Model YEFB-ECM		(2-3-4 rows)	(2-3-4 rows)	(2-3-4 rows)	(2-3-4 rows)	(2-3-4-5 rows)	-
Weight of the coil	kg	4.8 - 5.8 - 7.6	4.8 - 5.8 - 7.6	5.6 - 7.4 - 9.6	5.6 - 7.4 - 9.6	9.4 - 12.8 - 17.4 - 21.5	-
Water connection		G1/2" F	G1/2" F	G1/2" F	G1/2" F	G1" M	-

Model YEFB		(2-3-4 rows)	(2-3-4 rows)	(2-3-4 rows)	(2-3-4 rows)	(2-3-4-5 rows)	(2-3-4-5 rows)
Water content	l	1.4 - 2.2 - 2.9	1.4 - 2.2 - 2.9	1.9 - 2.8 - 3.8	1.9 - 2.8 - 3.8	3.4 - 5.0 - 6.7 - 8.4	3.4 - 5.0 - 6.7 - 8.4
Model YEFB-ECM		(2-3-4 rows)	(2-3-4 rows)	(2-3-4 rows)	(2-3-4 rows)	(2-3-4-5 rows)	-
Water content	l	1.5 - 2.2 - 2.9	1.4 - 2.2 - 2.9	1.9 - 2.8 - 3.8	1.9 - 2.8 - 3.8	3.4 - 5.0 - 6.7 - 8.4	-

YKEY and YKEY900 Hydro Cassette

2 and 4 pipe system

A complete range from 1.1 kW to 10 kW



The YORK YKEY Cassette units are designed for installation on a false ceiling, suitable for cooling and heating applications.

The ambient air drawn through the central air intake grill is blown into the circular heat exchanger, composed by copper pipes and aluminium fins, and then it comes out from the 4 sides of the cassette unit. Thanks to the special combination of air intake/air outlet grilles it is possible to obtain the pleasant COANDA effect.



CSR00 (Wall mounted)
Fan speed selector



CER00 (Wall mounted)
Thermostat with manual fan speed and automatic change over



CMR00 (Wall mounted)
Thermostat with manual fan speed and S/W change over

CER20 (Wall mounted)
Thermostat with auto. fan speed and automatic change over

CER30 (Wall mounted)
Thermostat with auto. fan speed and automatic change over for modulating valve



TUC03+ Terminal unit controller
BacNET and N2 Metasys network compatible



Features

- Cooling duty from 1.4 to 10 kW
- 2 and 4 pipes systems in all range
- Central air intake grill
- 4 sides air outlet plenum
- 2 panel sizes: 600 x 600 & 900 x 900
- Possible choice between 6 fan speeds
- Condensate pump integrated in all range
- 2/3 way valves fitted or supplied loose in all range
- Coloured versions, possible to change the colour of the grill and the frame
- Possible to select a complete range of controls
- Electric heater fitted as an option for 2 pipe range
- All metal parts insulated to avoid condensations
- EUROVENT Certified

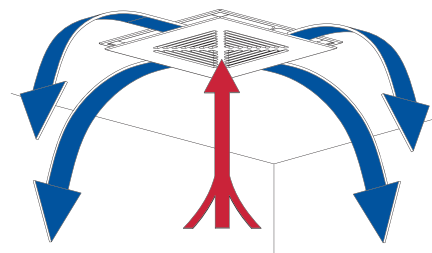

COANDA effect

The particular shape of the air outlet plenum is designed specifically in order to obtain the Coanda effect, a phenomenon for which the air outlet flow tends to adhere to the ceiling and falls down smoothly, without blowing directly towards people in the room: the optimal solution for an uniform and pleasant air diffusion.



YKEY/M Special version with micro-drilled metallic grill



YKEY/H-Special version with natural condensate water discharge



Selection software

YKEY and YKEY900 Hydro Cassette

1.1 kW to 10 kW



Technical features

YKEY model -2 pipes			621	622	623	921	922
Total cooling capacity [kW]	(1)	max	2.52	3.68	4.72	8.63	9.99
		med	1.78	2.84	3.82	6.49	8.24
		min	1.42	2.27	2.51	3.86	5.65
Sensible cooling capacity [kW]	(1)	max	2.12	2.79	3.7	6.1	7.64
		med	1.4	2.06	2.89	4.49	6.2
		min	1.08	1.63	1.81	2.61	4.13
Water flow in cooling [l/h]	(1)	max	433	633	812	1484	1718
		med	306	488	657	1116	1417
		min	244	390	432	664	972
Pressure drop in cooling [kPa]	(1)	max	7.8	10.9	16.5	20.1	26
		med	4.6	7.3	11.5	12.3	19
		min	3.2	5.2	6	4.5	9
Heating capacity [kW]	(2)	max	2.66	3.65	4.89	8.33	10.18
		med	1.78	2.7	3.8	5.7	7.91
		min	1.38	2.09	2.39	3.25	5.04
Water flow in heating [l/h]	(2)	max	458	628	841	1433	1751
		med	306	464	654	980	1361
		min	237	359	411	559	867
Pressure drop in heating [kPa]	(2)	max	7	9.4	14.9	12.1	17.4
		med	3.4	5.3	9.5	6.1	11
		min	2.2	2	4.1	2.2	4.9
Water content [l]			1.34	2.12	2.12	4.26	4.26

YKEY model -4 pipes			641	642	643	941	942
Total cooling capacity [kW]	(1)	max	1.76	3.11	3.88	7.49	9.04
		med	1.34	2.48	3.23	5.67	7.5
		min	1.1	2.04	2.25	3.41	5.2
Sensible cooling capacity [kW]	(1)	max	1.62	2.49	3.24	5.98	7.46
		med	1.17	1.91	2.61	4.42	6.08
		min	0.94	1.52	1.73	2.58	4.08
Water flow in cooling [l/h]	(1)	max	303	535	667	1288	1555
		med	230	427	556	975	1290
		min	189	351	387	587	894
Pressure drop in cooling [kPa]	(1)	max	7.5	11.2	16.7	23.2	32
		med	4.8	7.8	11.9	14.1	23
		min	3.6	5.7	6.6	5	12
Heating capacity [kW]	(3)	max	2.01	2.69	3.31	6.66	7.86
		med	1.47	2.2	2.84	5.32	6.75
		min	1.23	1.82	2.01	3.49	4.95
Water flow in heating [l/h]	(3)	max	173	231	285	573	676
		med	126	189	244	458	581
		min	106	157	173	300	426
Pressure drop in heating [kPa]	(3)	max	5.8	10.6	15.2	25	33.2
		med	3.3	7.4	11.8	15.9	25.6
		min	2.4	5.2	6.3	7.9	14.7
Water content [l]			1.34	2.12	2.12	4.26	4.26

Common features			641	642	643	941	942
Air flow [m³/h]		max	566	566	717	1420	1530
		med	351	351	525	813	960
		min	182	182	308	410	477
Sound power level [dB(A)]		max	49	49	58	54	63
		med	34	40	50	45	55
		min	30	34	37	30	40
Sound pressure level [dB(A)]		max	39.5	39.5	48.5	44.5	53.5
		med	24.5	30.5	40.5	35.5	45.5
		min	20.5	24.5	27.5	20.5	30.5
Power supply [V-ph-Hz]				230 /1 /50			
Power input [W]	max	52	52	86	127	161	
Absorbed current [A]	max	0.25	0.25	0.38	0.62	0.68	
Dimensions	Height	mm	328	328	328	360	360
	Width	mm	575	575	575	820	820
	Depth	mm	575	575	575	820	820

(1) Room temperature 27°C d.b., 19°C w.b. - Water temperature 7/12 °C

(2) Room temperature 20°C - Water temperature: 45/40 °C

(3) Room temperature 20°C - Water inlet temperature: 65/55°C

The sound pressure levels are 9 dB(A) lower than the sound power levels and apply to the reverberant field of a 100 m³ room and a reverberation time of 0.5 sec.



Manufacturer reserves the rights to change specifications without prior notice.

YKEY-ECM and YKEY900-ECM Inverter Cassette

2 and 4 pipe system

A complete range from 1.2 kW to 10.2 kW



EDCR (Wall mounted)

Thermostat with manual or automatic fan speed and automatic change over for modulating valve



TUC03+ Terminal unit controller

BacNET and N2 Metasys network compatible



The YORK YKEY-ECM Cassette units, with energy saving motors, are designed for installation on a false ceiling, suitable for cooling and heating applications.

The ambient air drawn through the central air intake grill is blown into the circular heat exchanger, composed by copper pipes and aluminium fins, and then it comes out from the 4 sides of the cassette unit. Thanks to the special combination of air intake/air outlet grilles it is possible to obtain the pleasant COANDA effect.

Features

- Cooling duty from 1.2 to 10.2 kW
- Brushless motor and inverter technology
- 2 and 4 pipes systems in all range
- Central air intake grill
- 4 sides air outlet plenum
- 2 panel sizes: 600 x 600 & 900 x 900
- Possible choice between 6 fan speeds
- Condensate pump integrated in all range
- 2/3 way valves fitted or supplied loose in all range
- Coloured versions, possible to change the colour of the grill and the frame
- Possible to select a complete range of controls
- Electric heater fitted as an option for 2 pipe range
- All metal parts insulated to avoid condensations
- EUROVENT Certified



YKEY/M-ECM Special version with micro-drilled metallic grill



YKEY/H-ECM Special version with natural condensate water discharge

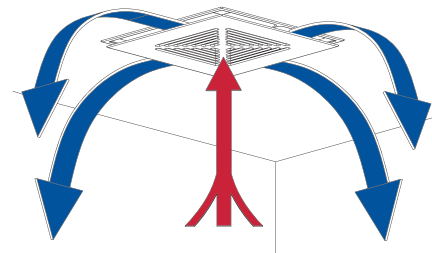

COANDA effect

The particular shape of the air outlet plenum is designed specifically in order to obtain the Coanda effect, a phenomenon for which the air outlet flow tends to adhere to the ceiling and falls down smoothly, without blowing directly towards people in the room: the optimal solution for an uniform and pleasant air diffusion.



Selection software

YKEY-ECM and YKEY900-ECM Inverter Cassette

1.2 kW to 10.2 kW



ECM the Energy Saving Technology

Brushless motor with inverter managed by dedicated controls. It permits to maintain extremely low electrical absorption and a continuous modulation of the air flow.

Technical features

YKEY-ECM model -2 pipes			621	622	624	922.1
Total cooling capacity [kW]	(1)	max	2.85	4.85	5.43	10.15
		med	2.37	3.64	3.99	7.61
		min	1.63	2.56	2.76	4.66
Sensible cooling capacity [kW]	(1)	max	2.42	3.79	4.17	7.87
		med	1.93	2.69	2.98	5.66
		min	1.26	1.85	1.99	3.34
Water flow in cooling [l/h]	(1)	max	491	835	935	1747
		med	408	627	687	1310
		min	281	441	475	802
Pressure drop in cooling [kPa]	(1)	max	9.2	17.2	40.5	23.2
		med	6.9	10.6	23.2	13.9
		min	3.9	6.1	12.3	5.8
Heating capacity [kW]	(2)	max	2.99	4.91	5.44	10.31
		med	2.38	3.52	3.98	7.51
		min	1.59	2.33	2.62	4.45
Water flow in heating [l/h]	(2)	max	515	845	936	1775
		med	410	606	686	1293
		min	274	401	455	766
Pressure drop in heating [kPa]	(2)	max	9	16.2	35.7	21.0
		med	5.9	8.9	20.4	12.0
		min	2.9	4.2	9.5	4.5
Water content [l]		1.34	2.12	2.15	4.26	

YKEY-ECM model -4 pipes			641	642	644	942.1
Total cooling capacity [kW]	(1)	max	1.87	3.52	4.30	9.10
		med	1.68	2.75	3.30	6.85
		min	1.22	2.03	2.32	4.32
Sensible cooling capacity [kW]	(1)	max	1.73	3.32	3.53	7.34
		med	1.52	2.5	2.58	5.33
		min	1.08	1.73	1.71	3.21
Water flow in cooling [l/h]	(1)	max	322	678	740	1566
		med	289	530	568	1179
		min	210	391	399	744
Pressure drop in cooling [kPa]	(1)	max	7.9	17	19.8	24.3
		med	6.6	11	12.5	14.5
		min	4.1	6.7	7.3	6.3
Heating capacity [kW]	(3)	max	2.21	3.3	3.72	7.48
		med	1.84	2.64	2.98	6.13
		min	1.37	2.04	2.23	4.41
Water flow in heating [l/h]	(3)	max	190	284	320	644
		med	158	227	256	528
		min	118	176	192	380
Pressure drop in heating [kPa]	(3)	max	7.1	15.6	19.6	26.2
		med	5.2	10.5	13.4	18.5
		min	3	6.6	8.1	10.2
Water content [l]		1.34	2.12	2.12	4.26	

Common features			641	642	644	942.1
Air flow [m³/h]		max	605	734	809	1497
		med	425	492	536	867
		min	235	260	260	384
Sound power level [dB(A)]		max	55	59	62	62
		med	47	49	51	51
		min	32	39	39	34
Sound pressure level [dB(A)]		max	45.6	49.6	52.6	52.6
		med	37.6	39.6	41.6	41.6
		min	22.6	29.6	29.6	24.6
Power supply [V-ph-Hz]			230 / 1 / 50			
Power input [W]	max	27	43	53	98	
Absorbed current [A]	max	0.25	0.39	0.46	0.80	
Dimensions	Height	mm	328	328	328	360
	Width	mm	575	575	575	820
	Depth	mm	575	575	575	820

(1) Room temperature 27°C d.b., 19°C w.b. - Water temperature 7/12 °C

(2) Room temperature 20°C - Water temperature: 45/40 °C

(3) Room temperature 20°C - Water inlet temperature: 65/55°C

The sound pressure levels are 9 dB(A) lower than the sound power levels and apply to the reverberant field of a 100 m³ room and a reverberation time of 0.5 sec.



Manufacturer reserves the rights to change specifications without prior notice.

YKEY and YKEY900 Cassette YKEY-ECM and YKEY900-ECM Inverter Cassette

Compatibility tables

Compatibility Options / Accessories / Models

Code	Designation	YKEY models					YKEY-ECM models																			
		621	622	623	-	921	922	641	642	643	-	941	942	621	622	-	624	-	922	641	642	-	644	-	942	
Heaters																										
KREL	Kit electrical heater with safety thermostat and relay	•	•	•	•	•	•	•																		
Remote controllers and thermostats (wall mounted)																										
CSR00	Fan speed selector (wall mounted) (not for ECM models)	•	•	•				•	•	•	•	•												•	•	
CMR00	Thermostat with manual fan speed and S/W change over (not for ECM models)	•	•	•				•	•	•	•	•												•	•	
CER00	Thermostat with manual fan speed, dead band, automatic change over (not for ECM models)	Compatible with electrical heaters																								
CER20	Thermostat with automatic fan speed, dead band, automatic change over (not for ECM models)	Compatible with electrical heaters																								
CER30	Thermostat with automatic fan speed, dead band, automatic change over for modulating valves (not for ECM models)	•	•	•				•	•	•	•	•												•	•	
EDCR	Thermostat with manual or automatic fan speed, dead band, automatic change over for modulating valves - Only for ECM models	Compatible with electrical heaters																								
OxU+OC716	Omnibus control + Remote Analogue Plus	Compatible with electrical heaters																								
OxU+OC216	Omnibus control + Remote Display console	Compatible with electrical heaters																								
Valves (Supplied loose) / Condensate pump / Air sensor / Water sensor (Factory fitted)																										
DTH2B2 (2p)	2-way on/off valves for 2-pipe systems, 230V	•	•	•	•	•	•																			
DTH2B2 (4p)	2-way on/off valves for 4-pipe systems, 230V												•	•	•	•	•	•	•	•	•	•	•	•	•	•
DTH3B2 (2p)	3-way 4-ports on/off valves for 2-pipe systems, 230V	•	•	•	•	•	•																			
DTH3B2 (4p)	3-way 4-ports on/off valves for 4-pipe systems, 230V												•	•	•	•	•	•	•	•	•	•	•	•	•	•
DTH2B0 (2p)	2-way on/off valves for 2-pipe systems, 24V	•	•	•	•	•	•																			
DTH2B0 (4p)	2-way on/off valves for 4-pipe systems, 24V												•	•	•	•	•	•	•	•	•	•	•	•	•	•
DTH3B0 (2p)	3-way 4-ports on/off valves for 2-pipe systems, 24V	•	•	•	•	•	•																			
DTH3B0 (4p)	3-way 4-ports on/off valves for 4-pipe systems, 24V												•	•	•	•	•	•	•	•	•	•	•	•	•	•
DTJ2BM (2p)	2-way modulating valves for 2-pipe systems, 24V	•	•	•	•	•	•																			
DTJ2BM (4p)	2-way modulating valves for 4-pipe systems, 24V												•	•	•	•	•	•	•	•	•	•	•	•	•	•
DTJ3BM (2p)	3-way 4-ports modulating valves for 2-pipe systems, 24V	•	•	•	•	•	•																			
DTJ3BM (4p)	3-way 4-ports modulating valves for 4-pipe systems, 24V												•	•	•	•	•	•	•	•	•	•	•	•	•	•
QEC10	230V/24V transformer	•	•	•	•	•	•	•	•	•	•	•	•	•	•	•	•	•	•	•	•	•	•	•	•	•
QEC20	Relay box for parallel connection for 230V actuators (not for ECM models)	•	•	•				•	•	•	•	•	•	•	•	•	•	•	•	•	•	•	•	•	•	•
QEC30	Relay box for parallel connection for 24V actuators (not for ECM models)	•	•	•				•	•	•	•	•	•	•	•	•	•	•	•	•	•	•	•	•	•	•
DT (2p)	Shut-off valves for 2-pipe systems supplied loose	•	•	•	•	•	•																			
DT (4p)	Shut-off valves for 4-pipe systems supplied loose												•	•	•	•	•	•	•	•	•	•	•	•	•	•
AS	Air sensor	•	•	•	•	•	•	•	•	•	•	•	•	•	•	•	•	•	•	•	•	•	•	•	•	•
WS	Water sensor	Compatible with CEL/CER/EDCR																								

- Compatible
- Compatible with conditions
- Not compatible

Dimensions and Weights



YKEY600 and YKEY600-ECM

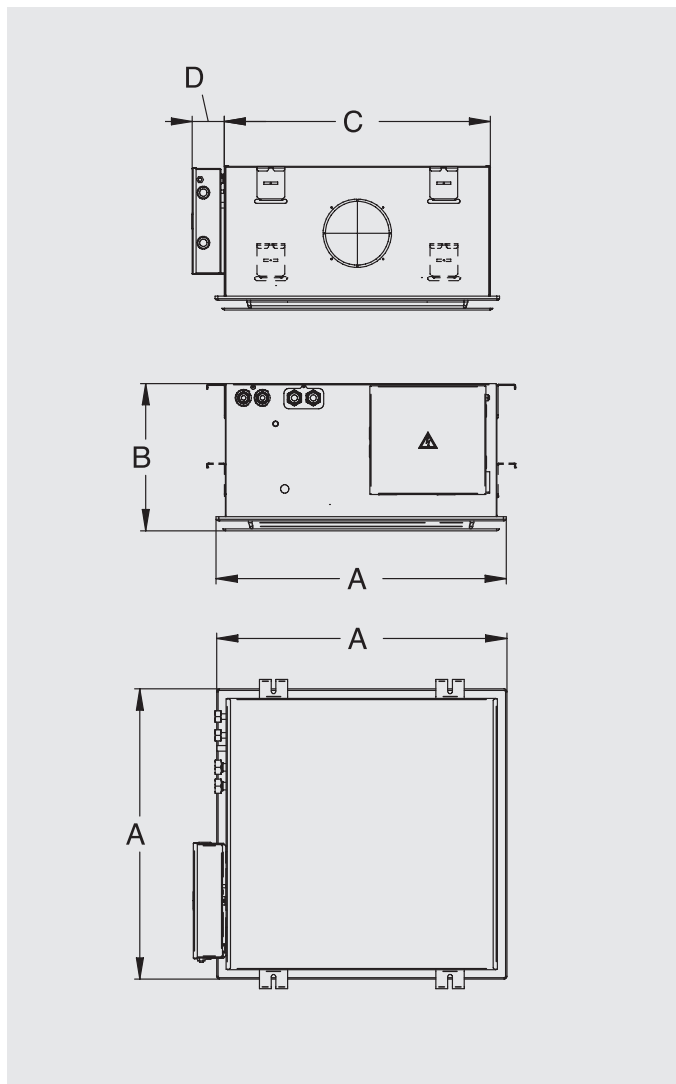

Model YKEY		621-641	622-642	623-643
A	mm	615	615	615
B	mm	328	328	328
C	mm	575	575	575
D	mm	75	75	75
Weight	kg	24 - 25,6	24 - 25,6	24 - 25,6

2 pipes installation	621	622	623
Water inlet	3/4 F	3/4 F	3/4 F
Water outlet	3/4 F	3/4 F	3/4 F

4 pipes installation	641	642	643
Cooling water inlet	3/4 F	3/4 F	3/4 F
Cooling water outlet	3/4 F	3/4 F	3/4 F
Heating water inlet	1/2 F	1/2 F	1/2 F
Heating water outlet	1/2 F	1/2 F	1/2 F

YKEY900 and YKEY900-ECM

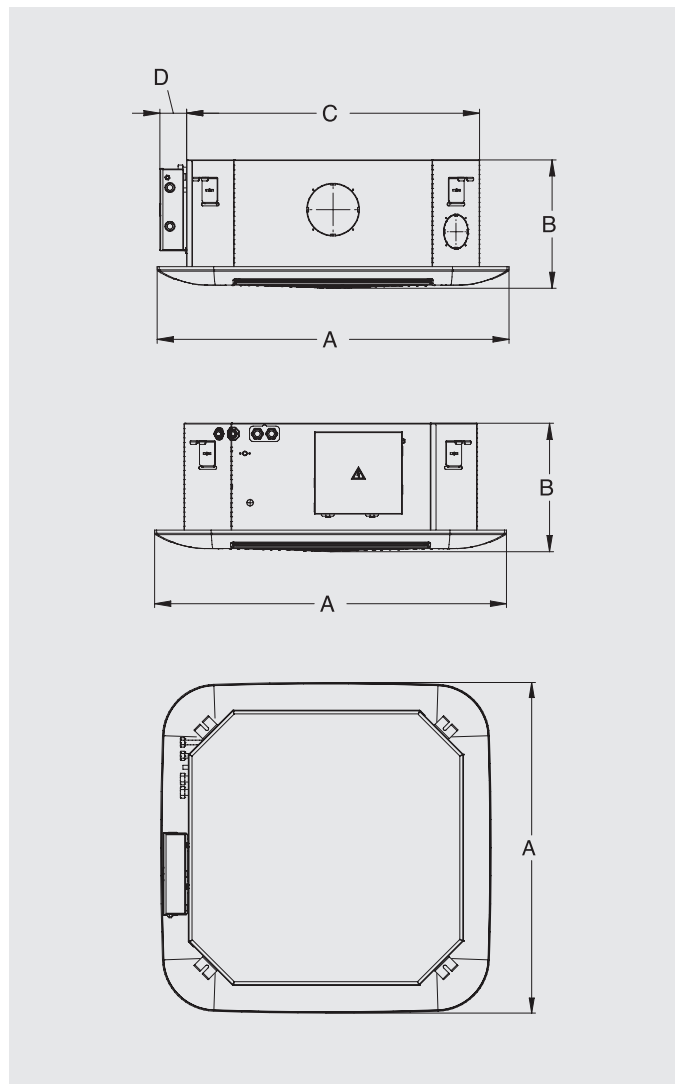

Model YKEY		921-941	922-942
A	mm	985	985
B	mm	360	360
C	mm	820	820
D	mm	75	75
Weight	kg	45	45

2 pipes installation	621	622
Water inlet	3/4 F	3/4 F
Water outlet	3/4 F	3/4 F

4 pipes installation	641	642
Cooling water inlet	3/4 F	3/4 F
Cooling water outlet	3/4 F	3/4 F
Heating water inlet	1/2 F	1/2 F
Heating water outlet	1/2 F	1/2 F

YHK Hydro Cassette

2 and 4 pipe system

A complete range from 1.3 kW to 11 kW

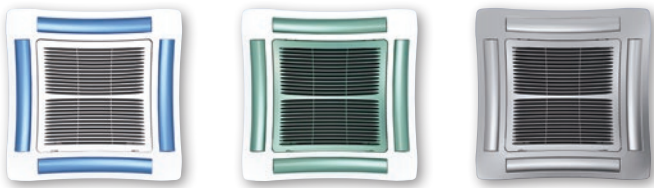

Coloured versions available as an option

YHK Hydro Cassette units are simple and elegant, discreet in their design. High standards of quality and reliability, combined with a wide range of accessories ensure a total solution for all comfort cooling and heating requirements.



Selection software

Wired controls



T9000 Series

Red Dot Product Design Award Winner 2020

- Touch Screen Display
- 2 or 4 pipes FCU
- 3-speed motors or ECM motors
- 2-wiring/3-wiring on/off valves or proportional valves
- Relay designed for 100,000 switching cycles
- Modbus or BACnet protocols



T7600 Series

- LCD Screen Display
- 2 or 4 pipes FCU
- On/off or proportional
- 3-speed motors or ECM motors
- Modbus RTU



Infrared control



TUC03+ Terminal unit controller

BacNET and N2 Metasys network compatible



Features

- Cooling duty from 1.3 to 11 kW
- 2 and 4 pipes systems in all range
- 2 sizes: 600 x 600 & 800 x 800
- Possible choice between 6 fan speeds
- Condensate pump integrated in all range
- 2/3 way valves fitted or supplied loose in all range
- Coloured versions, possible to change the colour of the grill and the frame
- Possible to select a complete range of controls
- Electric heater fitted as an option for all range (2 pipe only)
- All metal parts insulated to avoid condensations
- EUROVENT Certified

YHK Hydro Cassette

1.3 kW to 11 kW



Technical features

YHK model -2 pipes		20-2	25-2	40-2	50-2	65-2	95-2	110-2	
Total cooling capacity [kW]	(1)	max	1.92	2.64	4.26	4.93	6.08	9.39	10.93
		med	1.60	2.31	3.30	3.82	4.86	6.72	8.36
		min	1.25	1.82	2.23	2.91	4.18	5.27	5.27
Sensible cooling capacity [kW]	(1)	max	1.58	2.00	3.11	3.65	4.51	6.36	8.08
		med	1.29	1.72	2.35	2.75	3.53	4.42	6.00
		min	0.99	1.33	1.55	2.05	3.00	3.42	3.67
Water flow in cooling [l/h]	(1)	max	340	461	745	863	1 060	1 636	1 909
		med	280	402	574	667	845	1 166	1 453
		min	219	316	387	506	724	913	913
Pressure drop in cooling [kPa]	(1)	max	10	9.7	20.9	19.7	21.6	26.9	35.6
		med	7	7.6	13.0	12.4	14.3	14.7	21.8
		min	4.5	4.9	6.4	7.5	10.9	9.4	9.4
Heating capacity [kW]	(2)	max	2.24	2.80	4.37	5.15	6.50	9.23	11.72
		med	1.80	2.42	3.28	3.85	5.03	6.40	8.55
		min	1.38	1.85	2.12	2.85	4.27	4.92	5.12
Water flow in heating [l/h] *	(2)	max	340	461	745	863	1 060	1 636	1 909
		med	280	402	574	667	845	1 166	1 453
		min	219	316	387	506	724	913	913
Pressure drop in heating [kPa]	(2)	max	10.7	9.0	10.2	17.8	15.0	22.0	33.8
		med	7.2	6.9	6.1	10.6	9.4	11.4	19.2
		min	4.4	4.3	2.8	6.2	7.0	7.1	7.6
Heating capacity [kW]	(3)	max	4.6	5.7	9.3	10.6	13.1	19.8	23.7
		med	3.7	4.9	7	8.3	10.7	13.4	17.3
		min	2.8	4.2	4.9	6.1	8.6	10.3	10.3
Water flow in heating [l/h]	(3)	max	393	488	795	914	1 130	1 699	2 037
		med	315	422	598	709	874	1 155	1 484
		min	240	360	415	524	741	882	882
Pressure drop in heating [kPa]	(3)	max	9.9	8.4	12.5	16	17.5	20.9	28.9
		med	6.5	6.4	7.6	10	11.3	10.6	16
		min	4	4.8	4	5.9	8.4	6.7	6.7
Water content [l]		0.8	1.4	2.1	2.1	3.0	4.0	4.0	

YHK model -4 pipes		20-4	25-4	40-4	40-6	50-4	50-6	65-4	95-4	95-6	110-4	110-6	
Total cooling capacity [kW]	(1)	max	2.27	2.66	3.27	3.86	3.72	4.44	6.26	7.59	8.65	8.72	9.69
		med	1.93	2.33	2.61	3.02	2.96	3.47	4.98	5.60	6.27	6.84	7.75
		min	1.49	1.83	1.83	2.07	2.33	2.69	4.11	4.48	4.95	4.48	4.95
Sensible cooling capacity [kW]	(1)	max	1.84	1.94	2.49	2.88	2.88	3.37	4.61	5.71	6.37	6.67	7.26
		med	1.52	1.68	1.94	2.20	2.23	2.56	3.60	4.09	4.49	5.09	5.64
		min	1.13	1.32	1.32	1.47	1.72	1.94	2.93	3.21	3.49	3.21	3.49
Water flow in cooling [l/h]	(1)	max	401	464	574	664	655	764	1 090	1 326	1 488	1 529	1 667
		med	337	406	456	519	519	597	865	974	1 078	1 192	1 333
		min	260	318	318	355	406	462	712	777	851	777	851
Pressure drop in cooling [kPa]	(1)	max	13.5	8.8	13.4	10.5	17	14.0	18.9	26.9	25.0	34.7	32.0
		med	10	6.9	8.8	7.0	11.2	9.0	12.5	15.4	14.0	22.1	20.0
		min	6	4.6	4.6	4.0	7.2	6.0	8.8	10.3	9.0	10.3	9.0
Heating capacity [kW]	(4)	max	2.66	3.04	3.86	2.91	4.19	3.29	8.02	9.66	7.50	11.16	9.48
		med	2.23	2.66	3.04	2.71	3.33	2.66	6.33	7.15	5.63	8.80	6.78
		min	1.72	2.13	2.13	1.73	2.61	2.14	5.21	5.69	4.59	5.69	4.59
Water flow in heating [l/h] *	(4)	max	261	298	378	250	426	283	783	946	645	1 092	815
		med	219	260	298	233	341	229	618	697	484	858	583
		min	169	209	209	149	267	184	508	555	395	555	395
Pressure drop in heating [kPa]	(4)	max	11.4	8.7	13.3	6.7	15.0	8.4	17.2	24.0	11.8	31.2	15.0
		med	8.3	6.8	8.7	4.6	9.9	5.7	11.2	14.0	7.0	20.3	9.9
		min	5.2	4.6	4.6	2.6	6.4	3.9	7.9	9.3	4.9	9.3	4.9
Cooling water content [l]		1.0	1.4	1.4	1.7	1.4	1.7	3.0	3.0	3.6	3.0	3.6	
Heating water content [l]		0.6	0.7	0.7	0.5	0.7	0.5	1.4	1.4	1.0	1.4	1.1	

Common features		20-4	25-4	40-4	40-6	50-4	50-6	65-4	95-4	95-6	110-4	110-6
Air flow [m³/h]	max	610	520	710	710	880	880	1 140	1 500	1 500	1 820	1 820
	med	420	420	500	500	610	610	820	970	970	1 280	1 280
	min	310	310	320	320	430	430	630	710	710	710	710
Sound power level [dB(A)]	max	49	45	53	53	59	59	48	53	53	58	58
	med	40	40	45	45	49	49	40	40	40	48	48
	min	33	33	33	33	41	41	33	34	34	34	34
Sound pressure level [dB(A)]	max	40	36	44	44	50	50	39	44	44	49	49
	med	31	31	36	36	40	40	31	31	31	39	39
	min	24	24	24	24	32	32	24	25	25	25	25
Power supply [V-ph-Hz]		230 /1 /50										
Power input [W]	max	69.5	56.5	80.5	80.5	102.5	102.5	89.5	132.5	132.5	182.5	182.5
Absorbed current [A]	max	0.40	0.35	0.45	0.45	0.60	0.60	0.50	0.65	0.65	0.90	0.90
Dimensions	Height mm	275	275	275	275	275	275	303	303	303	303	303
	Width mm	575	575	575	575	575	575	820	820	820	820	820
	Depth mm	575	575	575	575	575	575	820	820	820	820	820

- (1) Room temperature 27°C d.b., 19°C w.b. - Water temperature 7/12 °C (2) Room temperature 20°C - Water temperature: 45/40 °C
 (3) Room temperature 20°C - Water inlet temperature: 70/60°C (4) Room temperature 20°C - Water inlet temperature: 65/55°C
 (5) The sound pressure levels are 9 dB(A) lower than the sound power levels and apply to the reverberant field of a 100 m³ room and a reverberation time of 0.5 sec.
 * Water flow values as Cooling, accordingly to the EUROVENT standards and UNI ENV 1397



Manufacturer reserves the rights to change specifications without prior notice.

YHK-ECM Inverter Hydro Cassette

2 and 4 pipe system

A complete range from 1.8 kW to 15.1 kW

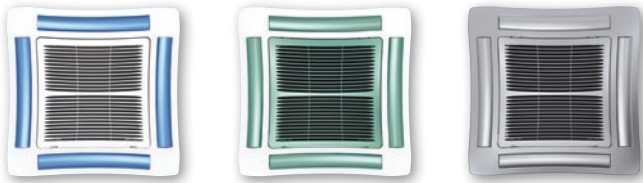

Coloured versions available as an option

YHK ECM water cassette is the result of significant technical and design research focused on providing an avant-garde product in terms of performance, low noise and control flexibility. YHK ECM series uses an innovative brushless electric motor controlled by an inverter card that varies the air flow continuously by means of a 1-10 V signal. The extreme efficiency, also at a low speed, makes it possible to greatly reduce electrical consumption (more than 75% less in comparison to a traditional motor) with absorption values, under normal operating conditions, that are no greater than 10 Watt in the entire range.

Wired controls



T9000 Series

- **Red Dot Product Design Award Winner 2020**
- Touch Screen Display
- 2 or 4 pipes FCU
- 3-speed motors or ECM motors
- 2-wiring/3-wiring on/off valves or proportional valves
- Relay designed for 100,000 switching cycles
- Modbus or BACnet protocols



T7600 Series

- LCD Screen Display
- 2 or 4 pipes FCU
- On/off or proportional
- 3-speed motors or ECM motors
- Modbus RTU



Infrared control



TUC03+ Terminal unit controller

BacNET and N2 Metasys network compatible



Features

- Cooling duty from 1.8 to 15.1 kW
- YHK: models with infrared control (standard)
- YHK-MP: models with wired control (accessory)
- 2 (-2) & 4 (-4 or -6) pipes systems
- 3 sizes: 600 x 600, 800 x 800 & 870 x 870
- Condensate pump integrated in all range
- 2/3 way valves fitted or supplied loose in all range
- Coloured versions, possible to change the colour of the grid and the frame
- All metal parts insulated to avoid condensations
- Inverter fan motor for a very quiet operation
- Electrical consumption reduced by up to 75%
- Specific range of controllers with master-slave function
- EUROVENT Certified



Selection software

YHK-ECM Inverter Hydro Cassette

1.8 kW to 15.1 kW



ECM the Energy Saving Technology

Brushless motor with inverter managed by dedicated controls. It permits to maintain extremely low electrical absorption and a continuous modulation of the air flow.

Technical features

YHK-ECM model -2 pipes			25-2	40-2	50-2	65-2	95-2	125-2	150-2
Total cooling capacity [kW]	(1)	max 10v	2.73	4.30	4.96	6.30	10.69	12.60	15.13
		med 5v	2.16	3.04	3.85	5.13	7.69	9.43	11.38
		min 1v	1.84	2.24	2.55	4.20	5.28	6.36	7.86
Sensible cooling capacity [kW]	(1)	max	2.07	3.15	3.68	4.69	7.83	9.31	11.41
		med	1.60	2.16	2.79	3.75	5.50	6.77	8.30
		min	1.35	1.57	1.80	3.02	3.68	4.45	5.58
Water flow in cooling [l/h]	(1)	max	473	744	864	1 089	1 848	2167	2602
		med	373	524	666	885	1 328	1622	1957
		min	317	385	441	723	909	1094	1352
Pressure drop in cooling [kPa]	(1)	max	10.1	15.1	19.7	22.7	33.0	22.7	31.8
		med	6.6	9.4	12.4	15.6	18.5	13.4	18.8
		min	4.9	4.6	5.9	10.9	9.4	6.6	9.6
Heating capacity [kW]	(2)	max	2.87	4.36	5.15	6.70	10.56	13.39	16.40
		med	2.22	2.98	3.85	5.30	7.34	9.59	11.86
		min	1.85	2.12	2.46	4.27	4.90	6.18	7.82
Pressure drop in heating [kPa]	(2)	max	9.4	13.2	17.8	21.6	28.1	21.5	31.0
		med	5.9	6.6	10.6	14.2	14.6	11.8	17.3
		min	4.3	3.6	4.7	9.6	7.0	5.4	8.2
Water content [l]			1.4	2.1	2.1	3.0	4.0	4.6	4.6

YHK-ECM model -4 pipes			25-4	40-6	50-6	65-4	95-6	125-4	150-4
Total cooling capacity [kW]	(1)	max	2.75	3.90	4.47	6.48	9.76	11.61	13.59
		med	2.17	2.81	3.51	5.29	7.14	8.86	10.59
		min	1.85	2.09	2.37	4.29	4.97	6.07	7.45
Sensible cooling capacity [kW]	(1)	max	2.06	2.92	3.40	4.80	7.29	8.87	10.68
		med	1.59	2.03	2.60	3.82	5.17	6.53	7.96
		min	1.34	1.49	1.70	3.07	3.51	4.33	5.4
Water flow in cooling [l/h]	(1)	max	476	676	779	1 120	1 697	1997	2337
		med	375	483	608	908	1 233	1524	1821
		min	318	359	409	740	856	1044	1281
Pressure drop in cooling [kPa]	(1)	max	9.5	10.3	13.1	19.8	30.1	22.6	30.4
		med	6.2	5.6	8.4	13.6	17.0	13.8	19.1
		min	4.6	3.3	4.1	9.4	8.8	7.0	10.1
Heating capacity [kW]	(3)	max	3.18	2.91	3.29	8.24	8.33	10.55	12.17
		med	2.51	2.20	2.66	6.65	6.27	8.4	9.8
		min	2.13	1.73	1.92	5.41	4.58	6.01	7.19
Water flow in heating [l/h]	(3)	max	311	288	326	805	818	907	1047
		med	245	217	263	649	616	722	843
		min	209	170	189	528	449	517	618
Pressure drop in heating [kPa]	(3)	max	9.4	6.7	8.4	18.1	14.3	19.9	25.7
		med	6.1	4.1	5.7	12.3	8.6	13.2	17.4
		min	4.6	2.6	3.2	8.5	4.9	7.2	10.0

Common features			25-4	40-6	50-6	65-4	95-6	125-4	150-4
Air flow [m³/h]		max	535	710	880	1 165	1 770	1 905	2480
		med	380	445	610	870	1 130	1 290	1 650
		min	310	310	360	630	710	790	1 025
Sound power level [dB(A)]		max	47	54	60	48	57	58	64
		med	39	43	50	39	47	49	55
		min	33	33	37	33	34	38	44
Sound pressure level [dB(A)]	(4)	max	38	45	51	39	48	49	55
		med	30	34	41	30	38	40	46
		min	24	24	28	24	25	29	35
Power supply [V-ph-Hz]					230 /1 /50				
Power input [W]									
Absorbed current [A]		max	28.5	44.0	81.0	43.5	126.0	105.0	195.0
		max	0.25	0.40	0.70	0.40	1.10	0.80	1.30
Dimensions		Height mm	275	275	275	303	303	304	304
		Width mm	575	575	575	820	820	869	869
		Depth mm	575	575	575	820	820	869	869

(1) Room temperature 27°C d.b., 19°C w.b. - Water temperature 7/12 °C

(2) Room temperature 20°C - Water temperature: 45/40 °C

(3) Room temperature 20°C - Water inlet temperature: 65/55°C

(4) The sound pressure levels are 9 dB(A) lower than the sound power levels and apply to the reverberant field of a 100 m³ room and a reverberation time of 0.5 sec.

* Water flow values as Cooling, accordingly to the EUROVENT standards and UNI ENV 1397



Condensate pump integrated in all sizes

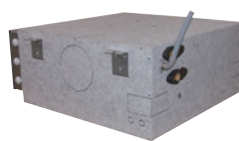

Metal parts insulated to avoid condensation



2 or 3 way valves fitted or supplied loose in all sizes



Outer casing as an option to integrate the water cassette into any environment



Manufacturer reserves the rights to change specifications without prior notice.

Compatibility table / Codes

Model with AC motor (without air diffuser)		YHK 20	YHK 25	YHK 40	YHK 50	YHK 65	YHK 95	YHK 110	-	-
Cassette YHK	2 pipe system	0079100K	0079000K	0079001K	0079002K	0079003K	0079004K	0079005K	-	-
	4 pipe system	0079110K	0079010K	0079011K	0079012K	0079013K	0079014K	0079015K	-	-
Cassette YHK-MP (IR remote control and sensor NOT included)	2 pipe system	0079170K	0079171K	0079172K	0079173K	0079174K	0079175K	0079176K	-	-
	4 pipe system	0079180K	0079181K	0079182K	0079183K	0079184K	0079185K	0079186K	-	-
Cassette YHK-E - with electric resistance	2 pipe system	-	0079060K	0079061K	0079062K	0079063K	0079064K	0079065K	-	-
Cassette YHK-MP-E - with electric resistance	2 pipe system	-	0079191K	0079192K	0079193K	0079194K	0079195K	0079196K	-	-
Cassette YHK-REB with remote electric board	2 pipe system	0079120K	0079020K	0079021K	0079022K	0079023K	0079024K	0079025K	-	-
	4 pipe system	0079130K	0079030K	0079031K	0079032K	0079033K	0079034K	0079035K	-	-
Model with ECM motor (without air diffuser)		-	YHK 25	YHK 40	YHK 50	YHK 65	YHK 95	-	YHK 125	YHK 150
Cassette YHK-ECM - basic model	2 pipe system	-	0079801K	0079802K	0079803K	0079804K	0079805K	-	0079807K	0079808K
	4 pipe system	-	0079811K	0079812K	0079813K	0079814K	0079815K	-	0079817K	0079818K
Cassette YHK-MP- ECM (IR remote control and sensor NOT included)	2 pipe system	-	0079911K	0079912K	0079913K	0079914K	0079915K	-	0079917K ⁽⁶⁾	0079918K ⁽⁶⁾
	4 pipe system	-	0079921K	0079922K	0079923K	0079924K	0079925K	-	0079927K ⁽⁶⁾	0079928K ⁽⁶⁾
Cassette YHK-ECM-E - with electric resistance	2 pipe system	-	0079841K	0079842K	0079843K	0079844K	0079845K	-	0079847K	0079848K
Cassette YHK-ECM-MP-E - with electric resistance	2 pipe system	-	0079901K	0079902K	0079903K	0079904K	0079905K	-	0079907K	0079908K

Mandatory accessories (units cannot work without them)

Air diffuser - intake grid, frame and louvres in RAL 9003 white colour	AKPA 600	AKPA 800	AKPA 900
--	----------	----------	----------

Accessories (factory fitted)

Valves (220V On/Off)			
3 way valve + mounting kit for 2 pipe models (factory fitted)	9079510	9079511	9079923
3 way valve + mounting kit for 4 pipe models (factory fitted)	9079512	9079513	9079933
2 way valve + mounting kit for 2 pipe models (factory fitted)	9079515	9079516	9079921
2 way valve + mounting kit for 4 pipe models (factory fitted)	9079517	9079518	9079931
2 way DN 15 balance valve for main coil + connection kit (fact. fitted) *	9079771	9079791	-
2 way DN 20 balance valve for main coil + connection kit (fact. fitted) *	-	9079792	-
2 way DN 15 balance valve for additional coil + connection kit (fact. fitted) *	9079773	9079793	-

Accessories (supplied loose)

Air diffusers / Panels	
Air diffuser - other colours (*)	Contact Johnson Controls

Valves (220V On/Off)			
3 way valve + mounting kit for 2 pipe models (not fitted)	9079500	9079501	9079922
3 way valve + mounting kit for 4 pipe models (not fitted)	9079502	9079503	9079932
2 way valve + mounting kit for 2 pipe models (not fitted)	9079505	9079506	9079920
2 way valve + mounting kit for 4 pipe models (not fitted)	9079507	9079508	9079930
2 way DN 15 balance valve for main coil + connection kit (not fitted) *	9079761	9079781	-
2 way DN 20 balance valve for main coil + connection kit (not fitted) *	-	9079782	-
2 way DN 15 balance valve for additional coil + connection kit (not fitted) *	9079763	9079783	-
Other type of valves	Contact Johnson Controls		

Other Accessories			
Outer casing OCA 600	9079240	-	-
Outer casing OCA 800	-	9079250	-
3 way valve + mounting kit for units with outer casing OCA (not fitted)	9079155	9079221	-
Fresh air duct FAD	6078005	-	-
Fresh air kit 1 way not suitable for units with outer casing OCA - FAK 600	9079230	-	-
Fresh air kit 1 way not suitable for units with outer casing OCA - FAK 800	-	9079231	-
Fresh air kit 1 way not suitable for units with outer casing OCA - FAK 900	-	-	9079235
MD-600 Metal Grid	9079420	-	-
MD-800 Metal Grid	-	9079417	-

CONTROLS for YHK (AC versions)	
Remote three speed control WM-3V (1) (4)	9066642
Remote three speed control + electronic thermostat and manual S/W switch JWC-T (2)	9066630K
Automatic speed control with electronic thermostat and S/W switch - JWC-AU (to be used with UPM-AU and UP-AU only) (2) (3)	9066632K
Automatic remote control with electronic thermostat, S/W switch and liquid crystal display T-MB (to be used with UPM-AU and UP-AU only) (2) (3)	9066331E
Automatic speed control with electronic thermostat to be mounted in the light wall box WM-503-AC-EC (to be used with UP-503-AC-EC only)	9066686
Electromechanical thermostat T2T (4) (5)	9060174
Power unit UPM-AU for JWC-AU and T-MB remote controls, fitted on the unit	9066641
Power unit UP-AU for JWC-AU and T-MB remote controls, not fitted on the unit	9066640
Power unit UP-503-AC-EC for WM-503-AC-EC remote control only, not fitted	9066687

Control accessories for all versions (supplied with separate packaging)	
Low temperature cut-out for control JWC-T	9053048
Low temperature cut-out for controls JWC-TQR, WM-503 and UP-AU power unit	3021090
T2 sensor to be used as Change-over for UP-AU power unit	9025310
Change-over 15-25 for control JWC-TQR	9053049
Receiver SEL2M	9079109

* For 4 pipes unit must consider both the valve for main coil than the valve for additional coil.
 (1) Not to be used with valves. (2) Can be used with valves and/or low temperature cut-out.
 (3) Can be used with Change Over. (4) Not suitable with -E electric heater. (5) Not to be used with low temperature cut-out. (6) Receiver included.

YHVP and YHVP-ECM Hydro High Wall

2 pipe system

A range from 1.17 kW to 3.81 kW



Wired Control T9000 Series

- Red Dot Product Design Award Winner 2020
- Touch Screen Display
- 2 or 4 pipes FCU
- 3-speed motors or ECM motors
- 2-wiring/3-wiring on/off valves or proportional valves
- Relay designed for 100,000 switching cycles
- Modbus or BACnet protocols



Electronic Infrared Control



TUC03+ Terminal unit controller

BacNET and N2 Metasys network compatible



2 Way Valve ON/OFF

with thermoelectric actuator.
Suitable for the connection with Ø 12 mm pipes

Features

- Available with standard AC motors or low energy EC motors
- Wired control or infrared control
- Automatic air sweep (-T and -MB variants only)
- Choice of 2 or 3 way valves fitted
- Condensate collection tray
- Air filter included
- Heat exchange coil
- EUROVENT Certified

Wired control (YHVP)

- 4 operation modes (Cool/Heat/Auto/Fan)
- Room temperature and setting
- Fan speed selector (Auto, low, medium and high)

Infrared control (YHVP-T)

- Wireless
- 5 operation modes (Cool/Heat/Auto/Dry/Fan)
- Sleep Mode
- Room Temperature setting
- Fan speed selection
- Timer
- Air flow direction setting
- LCD display

Note: model shown is -T variant with automatic air sweep function

YHVP and YHVP-ECM Hydro High Wall

1.17 kW to 3.81 kW



Technical features

Model		YHVP 1	YHVP 2	YHVP 3	YHVP 4	
Total cooling capacity [kW]	(1)	max	1.85	2.16	3.00	3.76
		med	1.49	1.82	2.30	3.23
		min	1.23	1.42	1.87	2.60
Sensible cooling capacity [kW]	(1)	max	1.44	1.73	2.24	2.93
		med	1.13	1.41	1.67	2.44
		min	0.91	1.06	1.33	1.91
Heating capacity [kW]	(2)	max	2.18	2.62	3.23	4.28
		med	1.68	2.13	2.37	3.53
		min	1.34	1.58	1.89	2.73
Air flow [m³/h]		max	375	480	545	790
		med	270	365	375	610
		min	205	250	280	440
Sound power level [dB(A)]		max	48	53	48	57
		med	41	47	40	51
		min	35	39	35	43
Sound pressure level [dB(A)]	(3)	max	39	44	39	48
		med	32	38	31	42
		min	26	30	26	34
Power supply [V-ph-Hz]		230V/1ph/50Hz				
Power input [W]	max	30	32	46	48	
Absorbed current [A]	max	0.16	0.16	0.23	0.23	
Dimensions	Height	mm	322	322	322	322
	Width	mm	880	880	1 185	1 185
	Depth	mm	212	212	212	212

(1) Room temperature 27°C d.b., 19°C w.b. - Water temperature 7/12 °C

(2) Room temperature 20°C - Water inlet temperature: 45/40°C.

(3) The sound pressure levels are 9 dB(A) lower than the sound power levels and apply to the reverberant field of a 100 m³ room and a reverberation time of 0.5 sec.

ECM the Energy Saving Technology

Brushless motor with inverter managed by dedicated controls. It permits to maintain extremely low electrical absorption and a continuous modulation of the air flow.

Technical features

Model		YHVP-ECM 1	YHVP-ECM 2	YHVP-ECM 3	YHVP-ECM 4	
Total cooling capacity [kW]	(1)	max 10v	1.98	2.24	3.27	3.72
		med 5v	1.57	1.86	2.52	3.03
		min 1v	1.16	1.46	1.82	2.33
Sensible cooling capacity [kW]	(1)	max	1.56	1.81	2.48	2.89
		med	1.19	1.45	1.85	2.27
		min	0.85	1.09	1.30	1.69
Heating capacity [kW]	(2)	max	2.35	2.74	3.57	4.20
		med	1.78	2.18	2.63	3.26
		min	1.26	1.63	1.83	2.40
Air flow [m³/h]		max	415	510	620	770
		med	290	375	420	550
		min	190	260	270	375
Sound power level [dB(A)]		max	52	55	53	57
		med	46	47	45	49
		min	35	40	37	43
Sound pressure level [dB(A)]	(3)	max	43	46	44	48
		med	37	38	36	40
		min	26	31	28	34
Power supply [V-ph-Hz]		230V/1ph/50Hz				
Power input [W]	max	15	21	20	30	
Absorbed current [A]	max	0.14	0.19	0.18	0.26	
Dimensions	Height	mm	322	322	322	322
	Width	mm	880	880	1 185	1 185
	Depth	mm	212	212	212	212

(1) Room temperature 27°C d.b., 19°C w.b. - Water temperature 7/12 °C

(2) Room temperature 20°C - Water inlet temperature: 45/40°C.

(3) The sound pressure levels are 9 dB(A) lower than the sound power levels and apply to the reverberant field of a 100 m³ room and a reverberation time of 0.5 sec.



Manufacturer reserves the rights to change specifications without prior notice.

Codes high wall fan coil units YHVP				
Unit without IR control without valve	YHVP 1	YHVP 2	YHVP 3	YHVP 4
Unit codes	0025001K	0025002K	0025003K	0025004K
Unit without IR control with 2 way valve	YHVP-2V 1	YHVP-2V 2	YHVP-2V 3	YHVP-2V 4
Unit codes	0025101K	0025102K	0025103K	0025104K
Unit without IR control with 3 way valve	YHVP-3V 1	YHVP-3V 2	YHVP-3V 3	YHVP-3V 4
Unit codes	0025201K	0025202K	0025203K	0025204K
Unit with IR control without valve	YHVP-T 1	YHVP-T 2	YHVP-T 3	YHVP-T 4
Unit codes	0025021K	0025022K	0025023K	0025024K
Unit with IR control with 2 way valve	YHVP-T-2V 1	YHVP-T-2V 2	YHVP-T-2V 3	YHVP-T-2V 4
Unit codes	0025121K	0025122K	0025123K	0025124K
Unit with IR control with 3 way valve	YHVP-T-3V 1	YHVP-T-3V 2	YHVP-T-3V 3	YHVP-T-3V 4
Unit codes	0025221K	0025222K	0025223K	0025224K
Unit with MB board without valve	YHVP-MB 1	YHVP-MB 2	YHVP-MB 3	YHVP-MB 4
Unit codes	0025011K	0025012K	0025013K	0025014K
Unit with MB board with 2 way valve	YHVP-MB-2V 1	YHVP-MB-2V 2	YHVP-MB-2V 3	YHVP-MB-2V 4
Unit codes	0025111K	0025112K	0025113K	0025114K
Unit with MB board with 3 way valve	YHVP-MB-3V 1	YHVP-MB-3V 2	YHVP-MB-3V 3	YHVP-MB-3V 4
Unit codes	0025211K	0025212K	0025213K	0025214K
Unit without IR control without valve with electrical coil	YHVP-E 1	YHVP-E 2	YHVP-E 3	YHVP-E 4
Unit codes	0025031K	0025032K	0025033K	0025034K
Unit without IR control with 2 way valve with electrical coil	YHVP-E-2V 1	YHVP-E-2V 2	YHVP-E-2V 3	YHVP-E-2V 4
Unit codes	0025131K	0025132K	0025133K	0025134K
Unit without IR control with 3 way valve with electrical coil	YHVP-E-3V 1	YHVP-E-3V 2	YHVP-E-3V 3	YHVP-E-3V 4
Unit codes	0025231K	0025232K	0025233K	0025234K
Unit with IR control without valve with electrical coil	YHVP-T-E 1	YHVP-T-E 2	YHVP-T-E 3	YHVP-T-E 4
Unit codes	0025041K	0025042K	0025043K	0025044K
Unit with IR control with 2 way valve with electrical coil	YHVP-T-E-2V 1	YHVP-T-E-2V 2	YHVP-T-E-2V 3	YHVP-T-E-2V 4
Unit codes	0025141K	0025142K	0025143K	0025144K
Unit with IR control with 3 way valve with electrical coil	YHVP-T-E-3V 1	YHVP-T-E-3V 2	YHVP-T-E-3V 3	YHVP-T-E-3V 4
Unit codes	0025241K	0025242K	0025243K	0025244K
Unit with MB board without valve with electrical coil	YHVP-MB-E 1	YHVP-MB-E 2	YHVP-MB-E 3	YHVP-MB-E 4
Unit codes	0025051K	0025052K	0025053K	0025054K
Unit with MB board with 2 way valve with electrical coil	YHVP-MB-E-2V 1	YHVP-MB-E-2V 2	YHVP-MB-E-2V 3	YHVP-MB-E-2V 4
Unit codes	0025151K	0025152K	0025153K	0025154K
Unit with MB board with 3 way valve with electrical coil	YHVP-MB-E-3V 1	YHVP-MB-E-3V 2	YHVP-MB-E-3V 3	YHVP-MB-E-3V 4
Unit codes	0025251K	0025252K	0025253K	0025254K

Controls	
WM-3V Wall control	9066642
JWC-T Wall control	9066630K
JWC-TQR Wall control	9066631K
T2T Wall control	9060174
T-MB Wall control (to be used with MB board only)	9066331E
RT03 infra-red remote control with receiver supplied with separate packaging (to be used with MB board only)	9025301
RT03 infra-red remote control supplied with separate packaging (to be used with MB board only)	3021203
Receiver for RT03 infra-red remote control supplied with separate packaging (to be used with MB board only)	9025300
PSM-DI Multifunction control (to be used with MB board only)	3021293
SEL-CVP Speed switch for controls: JWC-T and JWC-TQR	9025302
Electronic control accessories	
NTC low temperature cut-out thermostat for control JWC-TQR	3021090
TMM low temperature cut-out thermostat for control JWC-T	9053048
Change-Over CH 15-25 for control JWC-TQR	9053049
T2 Sensor (to be used as change-over or low temperature cut-out - for MB only)	9025310
Management system for a network of fan coils with MB electronic board	
Hardware / software supervisory system Net	9079118
Router-S for NET (default) or for BMS systems no provided by YORK	3021290
Relay output board SIOS	3021292

Codes high wall fan coil units YHVP-ECM

Unit without IR control without valve	YHVP-ECM 1	YHVP-ECM 2	YHVP-ECM 3	YHVP-ECM 4
Unit codes	0025501K	0025502K	0025503K	0025504K
Unit without IR control with 2 way valve	YHVP-ECM-2V 1	YHVP-ECM-2V 2	YHVP-ECM-2V 3	YHVP-ECM-2V 4
Unit codes	0025601K	0025602K	0025603K	0025604K
Unit without IR control with 3 way valve	YHVP-ECM-3V 1	YHVP-ECM-3V 2	YHVP-ECM-3V 3	YHVP-ECM-3V 4
Unit codes	0025701K	0025702K	0025703K	0025704K
Unit with IR control without valve	YHVP-ECM-T 1	YHVP-ECM-T 2	YHVP-ECM-T 3	YHVP-ECM-T 4
Unit codes	0025521K	0025522K	0025523K	0025524K
Unit with IR control with 2 way valve	YHVP-ECM-T-2V 1	YHVP-ECM-T-2V 2	YHVP-ECM-T-2V 3	YHVP-ECM-T-2V 4
Unit codes	0025621K	0025622K	0025623K	0025624K
Unit with IR control with 3 way valve	YHVP-ECM-T-3V 1	YHVP-ECM-T-3V 2	YHVP-ECM-T-3V 3	YHVP-ECM-T-3V 4
Unit codes	0025721K	0025722K	0025723K	0025724K
Unit with MB board without valve	YHVP-ECM-MB 1	YHVP-ECM-MB 2	YHVP-ECM-MB 3	YHVP-ECM-MB 4
Unit codes	0025511K	0025512K	0025513K	0025514K
Unit with MB board with 2 way valve	YHVP-ECM-MB-2V 1	YHVP-ECM-MB-2V 2	YHVP-ECM-MB-2V 3	YHVP-ECM-MB-2V 4
Unit codes	0025611K	0025612K	0025613K	0025614K
Unit with MB board with 3 way valve	YHVP-ECM-MB-3V 1	YHVP-ECM-MB-3V 2	YHVP-ECM-MB-3V 3	YHVP-ECM-MB-3V 4
Unit codes	0025711K	0025712K	0025713K	0025714K
Unit without IR control without valve with electrical coil	YHVP-ECM-E 1	YHVP-ECM-E 2	YHVP-ECM-E 3	YHVP-ECM-E 4
Unit codes	0025531K	0025532K	0025533K	0025534K
Unit without IR control with 2 way valve with electrical coil	YHVP-ECM-E-2V 1	YHVP-ECM-E-2V 2	YHVP-ECM-E-2V 3	YHVP-ECM-E-2V 4
Unit codes	0025631K	0025632K	0025633K	0025634K
Unit without IR control with 3 way valve with electrical coil	YHVP-ECM-E-3V 1	YHVP-ECM-E-3V 2	YHVP-ECM-E-3V 3	YHVP-ECM-E-3V 4
Unit codes	0025731K	0025732K	0025733K	0025734K
Unit with IR control without valve with electrical coil	YHVP-ECM-T-E 1	YHVP-ECM-T-E 2	YHVP-ECM-T-E 3	YHVP-ECM-T-E 4
Unit codes	0025541K	0025542K	0025543K	0025544K
Unit with IR control with 2 way valve with electrical coil	YHVP-ECM-T-E-2V 1	YHVP-ECM-T-E-2V 2	YHVP-ECM-T-E-2V 3	YHVP-ECM-T-E-2V 4
Unit codes	0025641K	0025642K	0025643K	0025644K
Unit with IR control with 3 way valve with electrical coil	YHVP-ECM-T-E-3V 1	YHVP-ECM-T-E-3V 2	YHVP-ECM-T-E-3V 3	YHVP-ECM-T-E-3V 4
Unit codes	0025741K	0025742K	0025743K	0025744K
Unit with MB board without valve with electrical coil	YHVP-ECM-MB-E 1	YHVP-ECM-MB-E 2	YHVP-ECM-MB-E 3	YHVP-ECM-MB-E 4
Unit codes	0025551K	0025552K	0025553K	0025554K
Unit with MB board with 2 way valve with electrical coil	YHVP-ECM-MB-E-2V 1	YHVP-ECM-MB-E-2V 2	YHVP-ECM-MB-E-2V 3	YHVP-ECM-MB-E-2V 4
Unit codes	0025651K	0025652K	0025653K	0025654K
Unit with MB board with 3 way valve with electrical coil	YHVP-ECM-MB-E-3V 1	YHVP-ECM-MB-E-3V 2	YHVP-ECM-MB-E-3V 3	YHVP-ECM-MB-E-3V 4
Unit codes	0025751K	0025752K	0025753K	0025754K

Controls

WM-S-ECM continuous fan speed control with S/W switch and liquid crystal display	9066644
T-MB Wall control (to be used with MB board only)	9066331E
RT03 infra-red remote control with receiver supplied with separate packaging (to be used with MB board only)	9025301
RT03 infra-red remote control supplied with separate packaging (to be used with MB board only)	3021203
Receiver for RT03 infra-red remote control supplied with separate packaging (to be used with MB board only)	9025300
PSM-DI Multifunction control (to be used with MB board only)	3021293
Electronic control accessories	
T2 Sensor (to be used as change-over or low temperature cut-out - for MB only)	9025310
Management system for a network of fan coils with MB electronic board	
Hardware / software supervisory system Net	9079118
Router-S for NET (default) or for BMS systems no provided by YORK	3021290
Relay output board SIOS	3021292